

SOUTHWORTH

Owner's Manual

LiftMat™



Model# _____

Serial# _____

Placed in service _____

Southworth Products Corporation

P.O. Box 1380/Portland, Maine 04104-1380

Phone 800-743-1000 • FAX 207-797-4734

www.southworthproducts.com
service@southworthproducts.com

Revised July 2015

NOTICE

DO NOT
EVER ATTEMPT
TO RAISE PLATFORM OR
SCISSOR LIFT OPEN
MECHANICALLY
(CRANE, HOIST, FORK TRUCK, ETC.)

THIS COULD DAMAGE THE
CYLINDERS AND WILL SEPARATE
THEM FROM THE BASE FRAME.

THE LIFT MUST BE
SCISSORED OPEN USING THE
HYDRAULIC POWER UNIT.

NOTICE

TABLE OF CONTENTS

INTRODUCTION	4
RESPONSIBILITY OF OWNERS AND USERS	5
SAFETY	6
SAFETY SERVICING	6
INSTALLATION INSTRUCTIONS	7
Preparation	7
Positioning the Lift	7
Hydraulic Connections	7
Electrical Connections	7
Testing	8
Completing Installation	8
OPERATING INSTRUCTIONS.....	9
Safety Alert Symbols and Signal Words	9
Labels and Precautionary Markings	10
Operating Procedure	11
MAINTENANCE	12
Hazards	12
Routine Periodic Maintenance.....	12
Repacking the Cylinder.....	13
Troubleshooting Check List	14
ORDERING REPLACEMENT PARTS.....	24

LIST OF FIGURES

Fig 1	Safe Servicing of the Lift.....	6
Fig 2	Center the Load	8
Fig 3	Secure the Load	8
Fig 4	Labels and Precautionary Markings	10
Fig 5	Pinch Points.....	11
Fig 6	Wiring Diagram, Single Phase.....	16
Fig 7	Three Phase Control Panel	17
Fig 8	Wiring Diagram, Three Phase	18
Fig 9	Hydraulic Schematic	19
Fig 10	Toe Guard Microswitch	19
Fig 11	LiftMat Assembly.....	20
Fig 12	Wagon Assembly	21
Fig 13	Cylinder Assembly	22
Fig 14	Motor Assembly	23

INTRODUCTION

The low profile LIFTMAT eliminates the need for installing costly pits. The Lift Mat's collapsed low height is low enough that all types of pallet jacks can be rolled onto it with the use of a small ramp.

This manual contains information to acquaint you with the safe and proper use and upkeep of the LIFTMAT. You should ensure that this manual is available to personnel working with the LIFTMAT and require its use by these personnel.

In the interest of safety please read the entire manual carefully and be familiar with its contents before you install, use or service the LIFTMAT. If you have any questions about any instructions in this manual, please contact your dealer or Southworth Products Corporation.

The LIFTMAT is fitted with an identification plate, located on the central cross member between the scissors legs (see fig. 5) The identification plate is stamped with the model number, capacity and serial number. This information should be provided when seeking spare part inquiries or technical support.

Southworth's product warranty is shown on the back cover of this manual.

Responsibility of Owners and Users

Inspection and Maintenance

The device shall be inspected and maintained in proper working order in accordance with Southworth's owner's manual.

Removal from Service

Any device not in safe operating condition such as, but not limited to, excessive leakage, missing rollers, pins, or fasteners, any bent or cracked structural members, cut or frayed electric, hydraulic, or pneumatic lines, damaged or malfunctioning controls or safety devices, etc. shall be removed from service until it is repaired to the original manufacturer's standards.

Deflection

It is the responsibility of the user/purchaser to advise the manufacturer where deflection may be critical to the application.

Repairs

All repairs shall be made by qualified personnel in conformance with Southworth's instructions.

Operators

Only trained personnel and authorized personnel shall be permitted to operate the lift.

Before Operation

Before using the device, the operator shall have:

- Read and/or had explained, and understood, the manufacturer's operating instructions and safety rules.
- Inspected the device for proper operation and condition. Any suspect item shall be carefully examined and a determination made by a qualified person as to whether it constitutes a hazard. All items not in conformance with Southworth's specification shall be corrected before further use of the equipment.

During Operation

The device shall only be used in accordance with this owner's manual.

- Do not overload.
- Ensure that all safety devices are operational and in place.

Modifications or Alterations

Modifications or alterations to any Southworth industrial positioning equipment shall be made only with written permission from Southworth.

SAFETY

The safety of all persons installing, operating, maintaining, repairing, or in the vicinity of the LIFTMAT is of paramount concern to Southworth. The LIFTMAT is a powerful machine with moving parts, and is **capable of causing personal injury if proper precautions are not taken**. Therefore, throughout this manual, Southworth has identified certain hazards which may occur in the use of the LIFTMAT and provided appropriate instruction or precautions which should be taken to avoid these hazards. In some cases, Southworth has also pointed out the consequences that may occur if these instructions or precautions are not followed. Southworth uses the following system of identifying the severity of the hazards associated with its products:

Signal Words: The word or words that designate a degree or level of hazard seriousness. The signal words for product safety signs are **DANGER**, **WARNING** and **CAUTION**.



Indicates an imminently hazardous situation which, if not avoided, will result in death or serious injury. This signal word is to be limited to the most extreme situations.



Indicates a potentially hazardous situation which, if not avoided, could result in death or serious injury.



Indicates a potentially hazardous situation which, if not avoided, may result in minor injury. It may also be used to alert against unsafe practices.

Please read and follow the instructions in this manual, including all safety instructions and precautions, carefully and completely.

SAFE SERVICING OF THE LIFT

This is the only safe way to work under a lift table. In this manual, we will refer you to this procedure many times. **In the interest of safety, please follow all of these steps whenever you work under the lift table:**

- **Remove the payload** from the table top.
- **Raise the lift table** to the full-up position. Do not let the table stop part way up.
- **Move the maintenance device** into position as shown in Fig. 1. Lower the table so the movable legs are resting against the maintenance device. This will release the pressure in the hydraulic system. If you do not do this, pressure may remain in the hydraulic system. If this pressure is released suddenly, you may be hurt, or the lift may be damaged.

Once in position, the maintenance device will keep the legs from moving and prevent the lift from dropping suddenly. The first part of Fig. 1 shows the maintenance device engaged, locking the rollers and legs in place. The second part of Fig. 1 shows the maintenance device not engaged. This allows the table to move freely.

- **Complete the work** under the lift table, then reverse the process to get the lift ready for operation.
- **Repeat the procedure** every time you must work under the lift. Do this even if you will only be under the table for a moment!

Maintenance Device not engaged

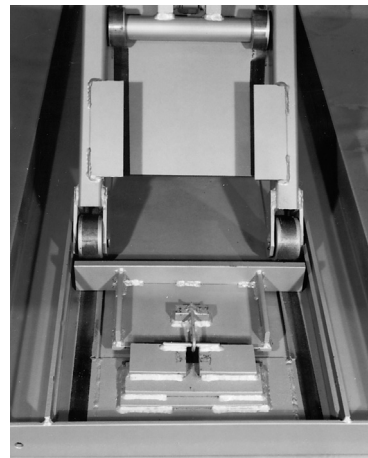

Maintenance Device engaged

Figure 1 – Safe Servicing of the Lift

INSTALLATION INSTRUCTIONS

PREPARATION

1. Before you start to install the lift, check for local codes and ordinances which may apply. It is your responsibility to obtain any necessary permits.
2. Read all of these installation instructions carefully. Be sure to read and understand all of the warnings!
3. The power unit will be mounted away from the lift; check the mounting arrangement for the power unit. The power unit should be sheltered from the weather. It should be mounted within 30 feet of the lift to minimize the pressure drop in the hydraulic system. Be sure the hydraulic lines have been installed properly.

⚠️WARNING

Protect the power unit from rain or moisture. If the electrical parts in the power unit get wet, workers may be hurt by electrical shock. The electrical parts may fail if they are wet.

⚠️WARNING

The electric motor in the lift can create sparks. Do not install the power unit in an area where flammable gases may be present.

POSITIONING THE LIFT

1. Remove the shipping material and unskid the lift. Make sure the packing material is removed from the toe guard and toe guard switches located on each end of the unit under the platform. On the front of this manual, confirm the model number, serial number, and date the lift is placed in service. You can find the model number and serial number on the identification plate (see fig. 5).
2. Move the lift into position, supporting the base frame of the lift. Install the lift using lag bolts to hold the lift in place. Mount the lift on a firm level surface, if necessary, insert shims to level the lift. Make sure to grout under each side rail to prevent the base frame from flexing.

⚠️WARNING

If the lift is mounted on an unstable surface, it may tip over when it is in use. You may be hurt, and the lift and load may be damaged.

HYDRAULIC CONNECTIONS

1. Mount the power unit in a desired location.
2. Connect the hydraulic line between the power unit and the lift.

Hydraulic Oil Specifications

DEXRON III ATF

⚠️CAUTION

It is very important to keep the hydraulic oil free of dirt, dust, metal chips, water, and other contamination. Most of the problems with hydraulic systems are caused by contamination in the oil.

⚠️WARNING

Be sure that the hydraulic line will not be pinched by the lift as it raises or lowers. If you allow the line to be pinched, the lift may not work properly. A hose may break, the lift table may drop suddenly, and someone may be hurt.

⚠️CAUTION

It is very important to keep the hydraulic oil free from dirt, dust, metal chips, water, and other contamination. Most of the problems with hydraulic systems are caused by contamination of the oil.

ELECTRICAL CONNECTIONS

⚠️DANGER

The lift may use a power supply of up to 460 Volt AC. This voltage can kill you. Do not work with the electrical parts unless you are a qualified electrician.

1. A lift with a 115 Volt power unit needs to have a designated 20 amp outlet and breaker servicing no other electrical devices.
2. On a lift designed for three-phase AC, you must be sure the pump and motor is turning in the right direction. The lift table should start to move quickly when you press the "up" or "down" button. If the lift table does not move in 2 or 3 seconds, do not try to operate the lift! Exchange any two of the three-phase leads. If this does not correct the problem, see the troubleshooting instructions at the end of this manual.

⚠️CAUTION

If you have a unit designed for three-phase AC and you connect the power so the motor runs backwards, the lift will not operate, and you may damage the pump. Do not operate the lift for more than 2 or 3 seconds if you think the motor might be turning backwards.

TESTING

1. Check the level of the hydraulic oil. With the lift in the lowered position, the hydraulic fluid in the tank should be within 3/4 of an inch from the top; add oil if necessary.
2. Clear the area around the lift. Remove any loose wires, lumber, or other material which might get in the way of the lift as it raises or lowers.
3. Operate the lift through its full range of travel. The lift should rise smoothly with a quiet humming sound, and lower smoothly and quietly. Raise and lower the lift a few times to check the clearances around the lift table.

⚠️WARNING

As the lift table moves up and down, “pinch points” are created at the places shown in Fig. 4. If you are standing too close to the lift when it is moving, your arm or leg may be caught in the moving parts, and you may be hurt. Stay away from the pinch points when the lift is moving.

COMPLETING INSTALLATION

1. Once you are sure the lift and ramp are positioned correctly, mark the locations of the lag holes on the floor, and drill the holes. If necessary, insert metal shims to level the base of the lift. Insert and tighten the lag bolts to secure the lift. Grout under the base rails to prevent vibration and distortion of the base frame.
2. Test the lift with the rated load. If the lift does not rise and you hear a loud squealing noise, the pressure relief valve is operating. Contact Southworth for instructions.

⚠️WARNING

If you hear a squealing noise from the pump, the pressure relief valve is operating. Do not continue to use the lift! The pump will over heat very quickly, and may be permanently damaged. Contact Southworth for instructions.

Always place the load in the center of the lift.

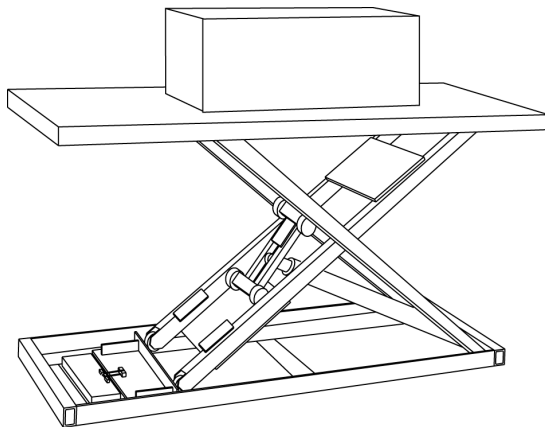

Figure 2 – Center the Load

If the load can roll or move, insert chocks or fasten the load down.

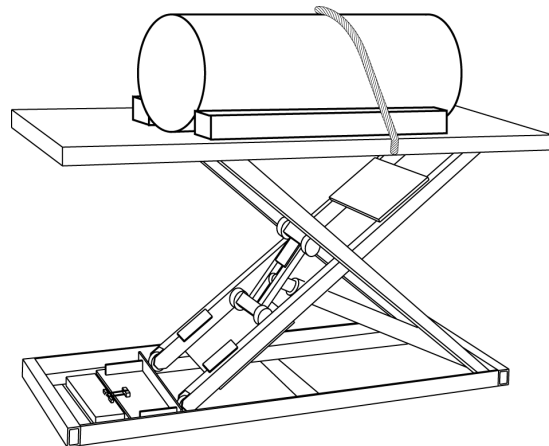

Figure 3 – Secure the Load

OPERATOR INSTRUCTIONS

SAFETY ALERT SYMBOLS AND SIGNAL WORDS

The safety of all persons operating, maintaining, repairing, or in the vicinity of this equipment is of paramount concern. This is a powerful machine with moving parts, and is capable of causing personal injury if proper precautions are not taken. Therefore, throughout this manual, certain hazards have been identified which may occur in the use of the machine, and there are appropriate instructions or precautions which should be taken to avoid these hazards. In some cases, there are consequences which may occur if instructions or precautions are not followed. Below are the symbols and signal words along with their definitions referenced from ANSI Z535.4 - Product Safety Signs and Labels.

Safety Alert Symbols

These are the safety alert symbols. They are used to alert you to potential physical injury hazards. Obey all safety messages that follow this symbol to avoid possible injury or death.



For use with **DANGER** signal word
(Red Background)



For use with **WARNING** signal word
(Orange Background)



For use with **CAUTION** signal word
(Yellow Background)

Signal Words

The meaning of different signal words as defined by ANSI Standard Z535.4 indicates the relative seriousness of the hazardous situation.



(Red Background)

DANGER indicates a hazardous situation which, if not avoided, will result in death or serious injury.



(Orange Background)

WARNING indicates a hazardous situation which, if not avoided, could result in death or serious injury.



(Yellow Background)

CAUTION, used with the safety alert symbol, indicates a hazardous situation which, if not avoided, could result in minor or moderate injury.



(Blue Background)

NOTICE is used to address practices not related to personal injury.



(Green Background)

SAFETY INSTRUCTIONS (or equivalent) signs indicate safety-related instructions or procedures.

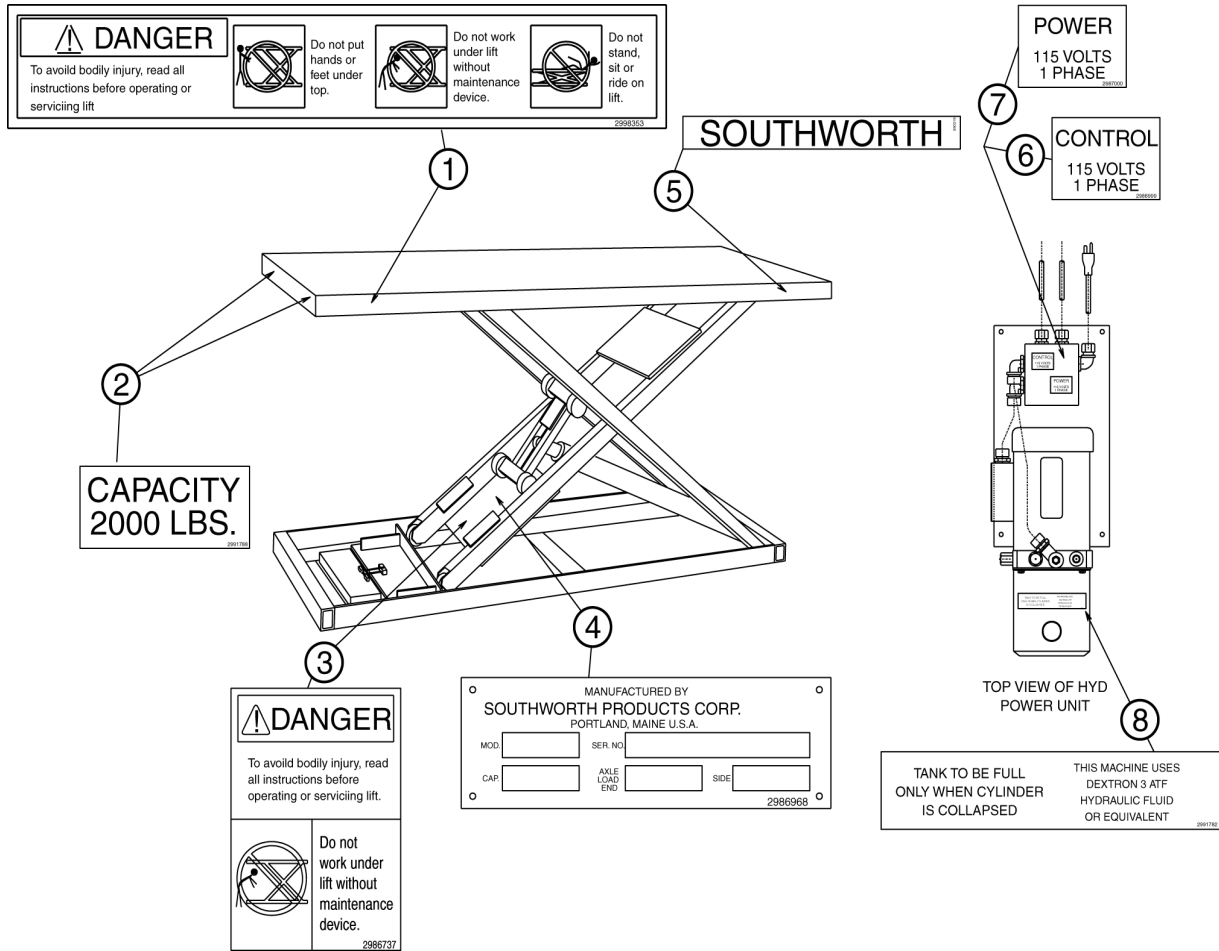

Item	Part #	Location
1.....	2986178	Table skirt (both sides - roller end)
2.....	Capacity Decals	
	500# 2998433	
	1000# 2998425	
	2000# 2998427	
	4000# 2998426	
	Platform ends; two per end, as shown	
3.....	2986737	Wagon support plate
4.....	2986968	Wagon support plate
5.....	5900191	Table skirt (both sides - hinged end)
7.....	Control Decals	
	2986999 (115/1/60)	
	2986998 (24/1/60)	
	5900166 (24VDC)	

Item	Part #	Location
	5900167 (110/1/50)	
	On junction box	
6.....	Power Decals	
	2987000 (115/1/60)	
	5900160 (230/1/60)	
	2987001 (208/3/60)	
	2987002 (230/3/60)	
	2987003 (460/3/60)	
	5900162 (575/3/60)	
	2991783 (12VDC)	
	5900161 (24VDC)	
	5900163 (110/1/50)	
	5900164 (220/1/50)	
	2999416 (380/3/50)	
	5900165 (415/3/50)	
	On junction box	
8.....	2991782	Hydraulic tank

Figure 4 – Labels and Precautionary Markings

OPERATING PROCEDURE

1. Before operating the lift, read and understand this entire section.

⚠ DANGER

The lift may use a power supply of up to 460 Volts AC. This voltage can kill you. Do not work with the electrical parts unless you are a qualified electrician!

2. Load the lift correctly.
 - Be sure that the load weighs no more than the maximum rated load for the lift. The maximum rated load is shown on the platform skirt.

⚠ WARNING

Do not try to lift a load that exceeds the maximum rating. If you try this, the lift may fail suddenly. Someone may be hurt, and the lift and load may be damaged.

- Place the load in the center of the lift table.
- Do not try to load the lift while the lift table is moving.
- If you are lifting pipes or other objects which may be able to roll or move, fasten them down, or chock them in place. (Fig. 2,3)

3. Be sure all workers are clear of the lift. Remove any lumber or other material which may fall onto the lift.

⚠ WARNING

Do not use the unit to lift people. This unit can not be equipped for this purpose.

⚠ WARNING

As the lift table moves up and down, "pinch points" are created at the places shown in fig. 4. If you are standing too close to the lift when it is moving, your arm or leg may be caught in the moving parts, and you may be hurt. Stay away from the pinch points when the lift is moving.

4. To operate the lift, press and hold the "up" button to raise the lift, and the "down" button to lower the lift. If the lift does not operate right away, turn off the lift and call a qualified maintenance worker.

⚠ WARNING

If you hear a squealing noise from the pump, the pressure relief valve is operating. Do not continue to use the lift! The pump will over heat very quickly, and may be permanently damaged. Contact Southworth for instructions.

⚠ WARNING

The warning labels on the lift are there for safety. If you find that the labels are worn or missing, or have been painted over, contact Southworth Products for replacement labels. (shown in fig. 5)

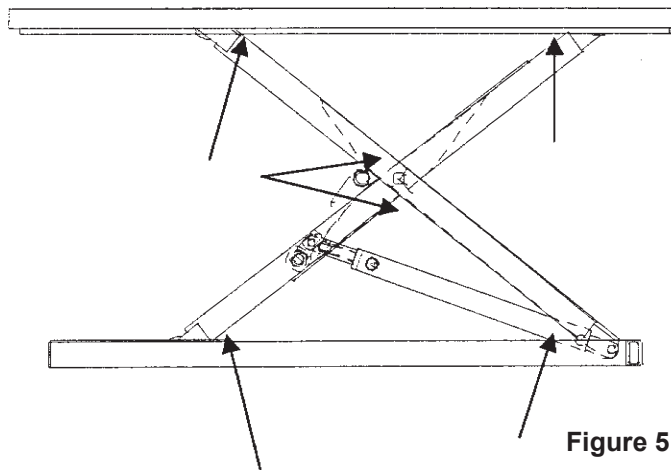

Figure 5 – Pinch Points

MAINTENANCE

All servicing should be done by qualified personnel. Qualified personnel should be able to read and understand wiring and hydraulic diagrams. They should be able to troubleshoot live electrical circuits safely and in accordance with accepted practice. **For safety's sake**, if in doubt, please contact your dealer or Southworth Products Corporation Customer Service Department at (800-743-1000).

HAZARDS

- There are several hazards you should be aware of as you service the lift:

DANGER

The lift may use a power supply of up to 460 Volts AC. This voltage can kill you. Do not work with the electrical parts unless you are a qualified electrician!

WARNING

- As the lift table moves up and down, “pinch points” are created at the places shown in Fig. 4. If you are standing too close to the lift when it is moving, your arm or leg may be caught in the moving parts, and you may be hurt. Stay away from the pinch points when the lift is moving.
- A falling lift can cause severe personnel injury. Before working under the lift, raise the lift and insert the maintenance device. Do this every time you work under the lift. (See page 3)
- Do not change the setting on the relief valve. If you do, this may cause the lift to fail. The lift may suddenly drop. Someone may be hurt, and the lift and the load may be damaged. The hydraulic parts in the lift are designed to handle a certain amount of pressure. The relief valve is designed to relieve this pressure before it becomes too great. The relief valve has been included for the protection of all of the workers who operate the lift.
- Release of fluids under high pressures can cause personal injury. Before you disconnect any part of the hydraulic system, be sure to release the hydraulic pressure.
- The warning labels on the lift are there for the safety of the operators. If the

labels are worn or missing, or have been painted over, replace them before releasing the lift for operation. (Fig 5.)

ROUTINE PERIODIC MAINTENANCE

EVERY MONTH:

- Visually inspect the leg rollers, center pivot bushings and pins, cylinder clevis pins and bushing, and the leg hinge pins and bushing for signs of wear. Contact Southworth for instructions for repair of the center pivot pins and bushings.

WARNING

If you are going to repair the center pivot pins and bushings, you must support the lift table in a special way. Each set of leg plates, on both sides of the unit, must be clamped together firmly, using large C-clamps. You can not use the standard maintenance device with the pivot pins removed, they will not support the table top. If you do not support the lift table correctly, the top may suddenly drop when the pivot pins are removed. Please contact The Southworth Customer Service Dept.

- Apply oil or WD-40 to the parts listed in the last step.

NOTE: although the bearings are “lifetime lubricated” their performance may be extended by additional periodic lubrication.

- Check the level and appearance of the hydraulic fluid, with the lift in the lowered position the hydraulic fluid in the tank should be within 1/8” from the top. Change the oil if it has darkened, or feels gritty or sticky.

CAUTION

It is important to use hydraulic fluid with the correct grade and properties. See the hydraulic specification in this manual. (Fig. 15)

EVERY SIX MONTHS OR 500 HOURS OF OPERATION, WHICHEVER COMES FIRST:

- Raise the lift and insert the maintenance device. (See page 3)
- Check all hydraulic fittings and hoses, and tighten the connections if necessary. Sometimes the fittings can be worked loose by vibrations from the power unit.

▲WARNING

If a hydraulic fitting becomes loose, or if a hydraulic hose breaks, the hydraulic fluid may escape from the system under pressure. If the lift is raised when this happens, it can drop quickly. Someone may be hurt, or the lift or load may be damaged.

- The clear plastic vent line and the cylinder rod should be free of hydraulic fluid. If you find much fluid in either place, the cylinder seals may be leaking. (It is also possible the tank may be overfilled.) See the section on "Repacking the cylinder."
- Drain and discard the hydraulic fluid. Remove the suction filter, inside the tank. Using a high-pressure air hose blow the filter clean. Reinstall the filter in the tank and reassemble.
- Refill the tank with new hydraulic fluid to within 3/4 of an inch from the top.

▲CAUTION

If you continue to use the fluid after it has "worn out," the moving parts in the system will wear more quickly.

▲WARNING

The warning labels on the lift are there for safety. If you find that the labels are worn or missing, or have been painted over, contact Southworth Products for replacement labels. (Shown in Fig. 5)

REPACKING THE CYLINDER

This section will tell you how to repack the Lift Mat Cylinder (see fig. 13). The cylinder packing kit can be purchased through the Southworth Parts Department at (207) 878-1000 or (800) 743-1000. When ordering please specify the model number and the serial number of the lift.

Before beginning this procedure, read and understand this entire section.

WARNING!

Before working underneath the lift, always raise the lift and insert the maintenance device. Failure to do so may result in damage to the lift and severe personal injury!

1. Before you disassemble the old cylinder, be sure you have these items on hand:

- A repacking kit. Parts may be damaged when you disassemble the cylinder. You should have replacement parts on hand so you can reassemble the lift and use it immediately.
 - A supply of new hydraulic oil. Contaminated oil may damage the new packing.
 - A container to catch the used oil.
 - A clean place to work. Choose a place which will not be damaged if you spill some oil.
2. Raise the lift and insert the maintenance device. (See page 3)
 3. Activate the down button to lower the lift onto the maintenance device and to relieve pressure from the cylinder.
 4. Disconnect the electrical power at the main disconnect or circuit breaker, or unplug the machine. This will prevent the lift from moving accidentally while you are working on it.
 5. Disconnect all hydraulic lines and drain them into a container.
 6. Grind the welds on the upper Clevis pin or remove the keeper on the Clevis pin that holds the cylinder to the wagon assemble.(Fig. 12)
 7. Slide the upper clevis pin out removing the rod end of the cylinder from the wagon assembly (it is not necessary to remove the cylinder from the lift table).
 8. Remove the retainer ring to allow the cylinder rod to pull apart from the cylinder barrel. (Fig.13)
 9. When repacking the cylinder remove each piece to be replaced and clean the area thoroughly removing all dirt and fibers.
 10. Replacement of the O-rings, Backup rings, wear ring, piston seal, Rod wiper, Rod seal, and inner O-ring is very important. To replace these the clevis needs to be removed. When complete replace the clevis to original position.(Fig.13)
 11. When the replacement of the cylinder seals and O-rings is complete a general inspection of the cylinder rod and barrel is required. The rod and barrel should appear smooth, having no dents, scars or pits cause by rust or any other foreign object. If these conditions are found contact your local Southworth Dealer.
 12. Lubricate the seals and O-rings with clean grease or oil. Carefully insert the piston and rod back into the cylinder. Be very careful not to pinch or tear any of the new seals or O-rings as they pass the shoulder inside the cylinder. It is helpful to tip the rod assembly and twist it as you slide it into the cylinder. Once the piston is inside the cylinder, it should slide easily.
 13. With the cylinder reassembled replace the retaining ring, make sure the ring snaps into place solidly.
 14. Reconnect the cylinder to the wagon assembly in the lift. Reconnect all hydraulic lines and vent lines. (Fig. 12+13)
 15. Replace the hydraulic fluid that was lost with an equal amount of fresh oil.
 16. Turn the electrical power on and press the up button. The pump will self-prime and after a few seconds the cylinder

will lift the table off the maintenance device. Remove the maintenance device and cycle the lift up and down a few times to remove any air pockets and to check for leaks.

17. If you have spilled any oil, **clean it up!**



Spilled hydraulic oil is very slippery, and may present a fire hazard. Always clean up any spilled oil.

TROUBLESHOOTING

PROBLEM	POSSIBLE CAUSE	CHECK THIS
Lift will not raise	Weight of load too heavy	Check the actual weight of the load
	Motor not running	Check the main disconnect switch, fuses, and wiring to the motor. A 20 amp, designated braker must be supplied for 110V
	Hydraulic oil level low	When lift is raised as far as possible, oil level should be 3/4" from bottom of tank. When lift is down, 3/4" from top
	Lift has reached its upper limit	Upper limit switch may need to be adjusted
	Motor may be "single phasing"	If motor hums but does not turn, check motor wiring and line fuses.
	Motor voltage too low	Supply voltage should be +/- 10% of the rating at the motor terminals.
	Tank vent plugged	If supplied, remove solid plug from tank, insert vent plug.
	Suction filter clogged	Clean suction filter as described in periodic maintenance
	Vacuum leak in suction line	Check all fittings in suction line
	Down valve may be energized	Check wiring to down valve, and solenoid in the valve
	Missing coupling	Check to insure the coupling has been installed between the pump and motor
The lift fails to hold	Down valve may be leaking	Remove down valve and inspect for debris which may be preventing it from closing.
	Down valve may be energized	Check the solenoid in the valve with a volt meter.
	Cylinder may be leaking	Check for oil in cylinder in the vent line.
Lift will not lower	Down valve may be de-energized	Check the solenoid in the valve with a volt meter
	Flow control needs adjustment	Adjust flow control as needed
Lift raises too slowly	Voltage may be low	Check voltage at motor to ensure proper voltage is being supplied
	Foreign material clogging suction filter, breather cap or pressure line	Remove necessary components and clean
	Pump may be overheating due to insufficient oil	Check oil level and oil viscosity
Lift lowers too slowly	Down valve may not be fully open or stuck closed	Remove down valve and clean
	Flow control may need adjustment	Adjust flow control as needed

If the steps listed above do not solve the problem, please call the Southworth's Customer Service Department

TROUBLESHOOTING WARNINGS

All servicing should be done by qualified personnel. Qualified personnel should be able to read and understand wiring and hydraulic diagrams. They should be able to troubleshoot live electrical circuits safely and in accordance with accepted practice. **For safety's sake**, if in doubt, please contact your dealer or Southworth Products Corp.

Before servicing the lift, **read and understand this entire section and the section entitled "Operating Instructions."**

⚠️ WARNING

Before working underneath the lift, always raise the lift and insert the maintenance devices, as shown in Figure 1. Failure to do so may result in damage to the lift and severe personal injury!

IF THE LIFT WILL NOT RAISE:

⚠️ CAUTION

Do not continue to hold the "up" button for more than 2 or 3 seconds. You may damage the pump.

⚠️ WARNING

Do not change the relief valve setting. This valve has been included for the protection of workers who install, use, or service the lift. If it is ever necessary to repair or reset the valve, contact Southworth Products Corp. for instructions.

⚠️ WARNING

Do not disconnect the up limit switch. Instead, loosen the adjusting screw, and change the position of the arm. If you do disconnect the switch, when the lift platform moves up, it may not stop at the correct point. If the platform rises above the normal stopping point, the frame of the unit may be damaged. People working nearby may be hurt.

⚠️ CAUTION

If cavitation is allowed to continue, the pump may be damaged, and may have to be replaced.

If the lift elevates, but fails to hold a load:

⚠️ WARNING

Failure to insert the maintenance devices may result in damage to the lift and severe personal injury!

IF THE LIFT FAILS TO LOWER:

⚠️ WARNING

Failure to insert the maintenance devices may result in damage to the lift and severe personal injury!

⚠️ DANGER

Do not try to adjust the flow control while pressing the "down" button. If you try this, the lift table may drop suddenly, and you may be hurt.

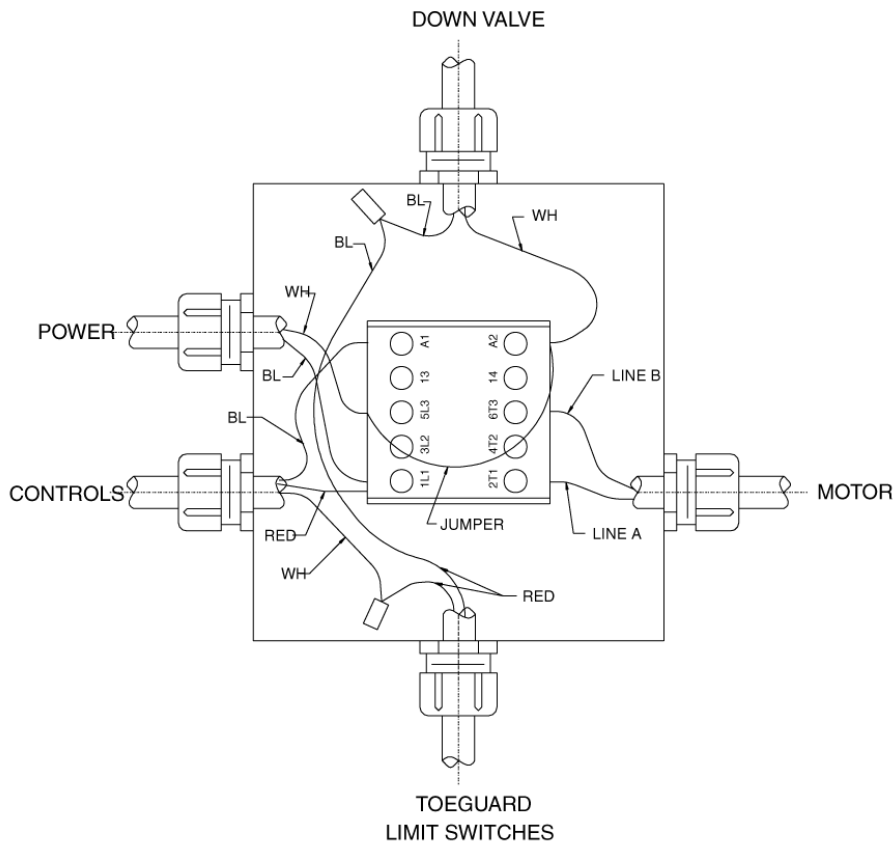

NOTE: ENTRY LOCATIONS MAY DIFFER FROM THOSE SHOWN.
GROUND CONNECTIONS, ALTHOUGH NOT SHOWN, ARE REQUIRED.

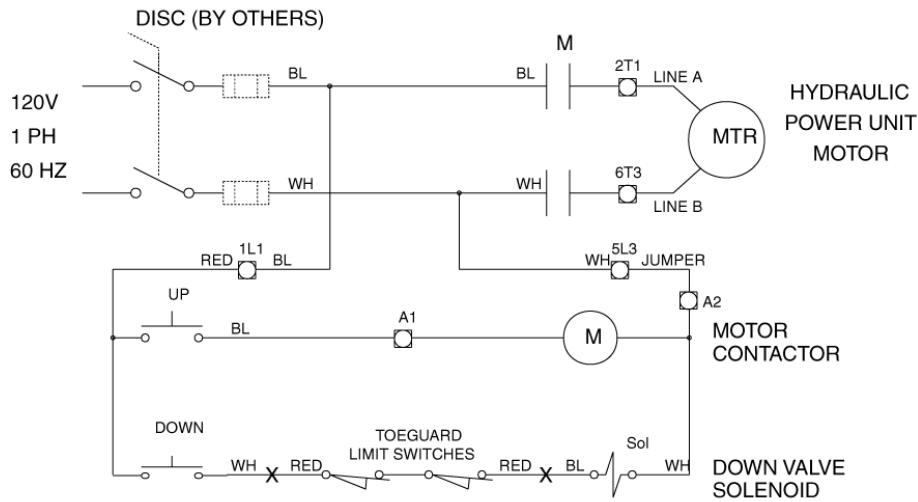

NOTE: WIRE TO THE N.O. CONTACTS OF THE TOEGUARD LIMIT SWITCHES.
UNDER NORMAL OPERATING CIRCUMSTANCES THE CONTACTS WILL BE HELD
CLOSED BY THE MECHANICAL TOEGUARD.

□ - INDICATES TERMINAL ON CONTACTOR X - INDICATES WIRE SPLICE

115 Volt Single Phase Figure 6 Wiring Diagrams

208/230/460V-3PH-60HZ
SUPPLY VOLTAGE
(FROM FUSED DISCONNECT)

NOTE: GROUND CONNECTIONS NOT SHOWN.
FOR GROUND CONNECTIONS USE
SUPPLIED GROUNDING TERMINAL.

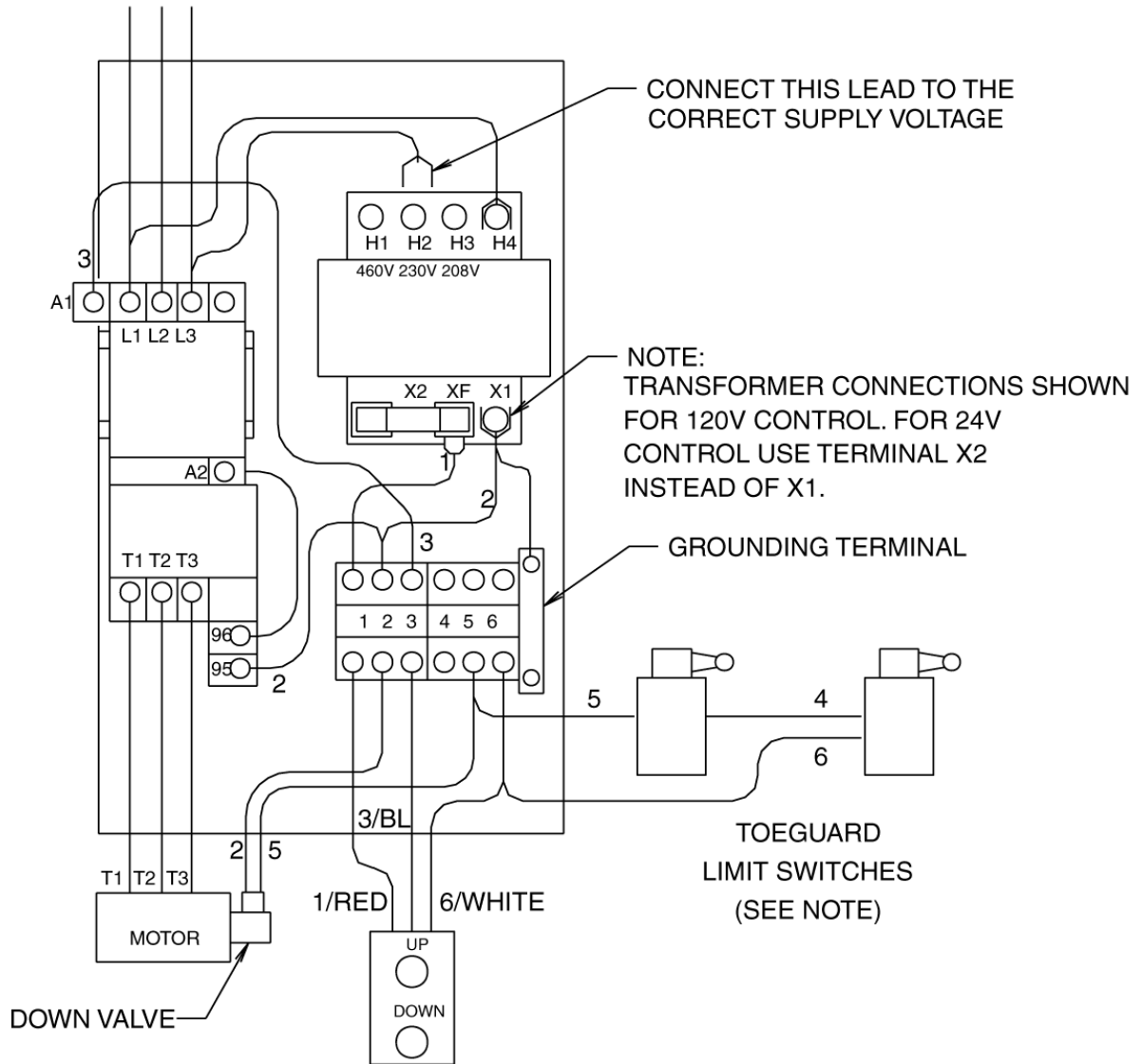
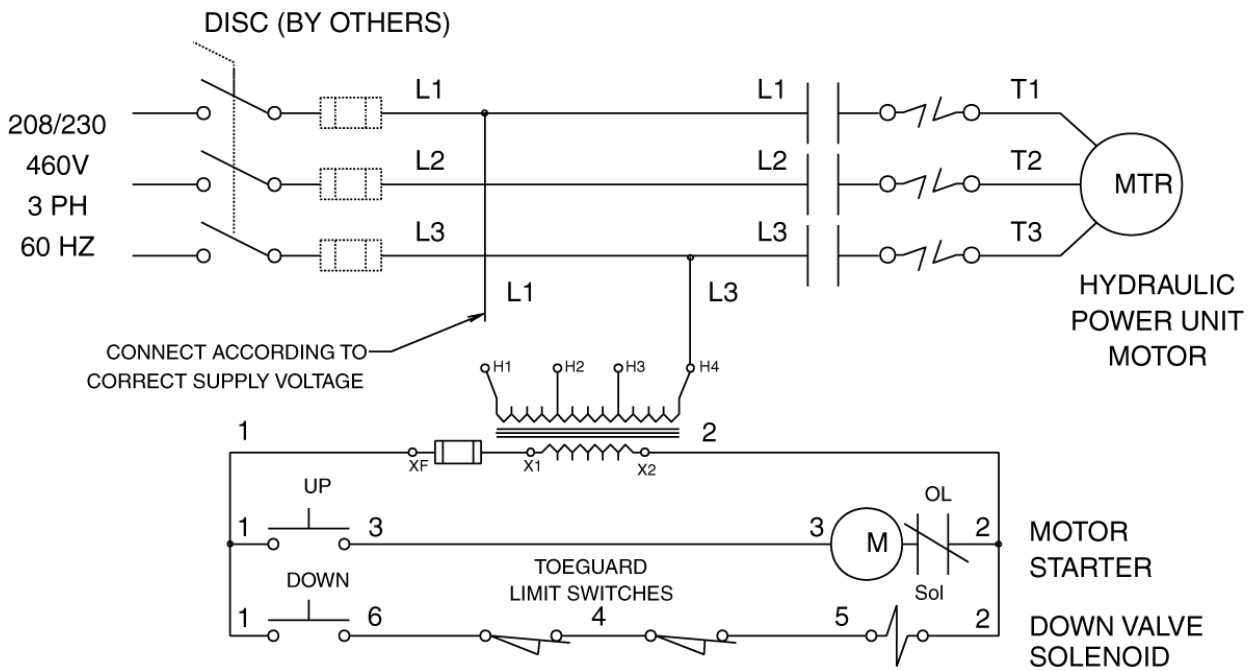

Figure 7 Three Phase Control Panel



NOTE: WIRE TO THE N.O. CONTACTS OF THE TOEGUARD LIMIT SWITCHES.
UNDER NORMAL OPERATING CIRCUMSTANCES THE CONTACTS WILL BE HELD CLOSED BY THE MECHANICAL TOEGUARD.

Figure 8 Three Phase Wiring Diagrams

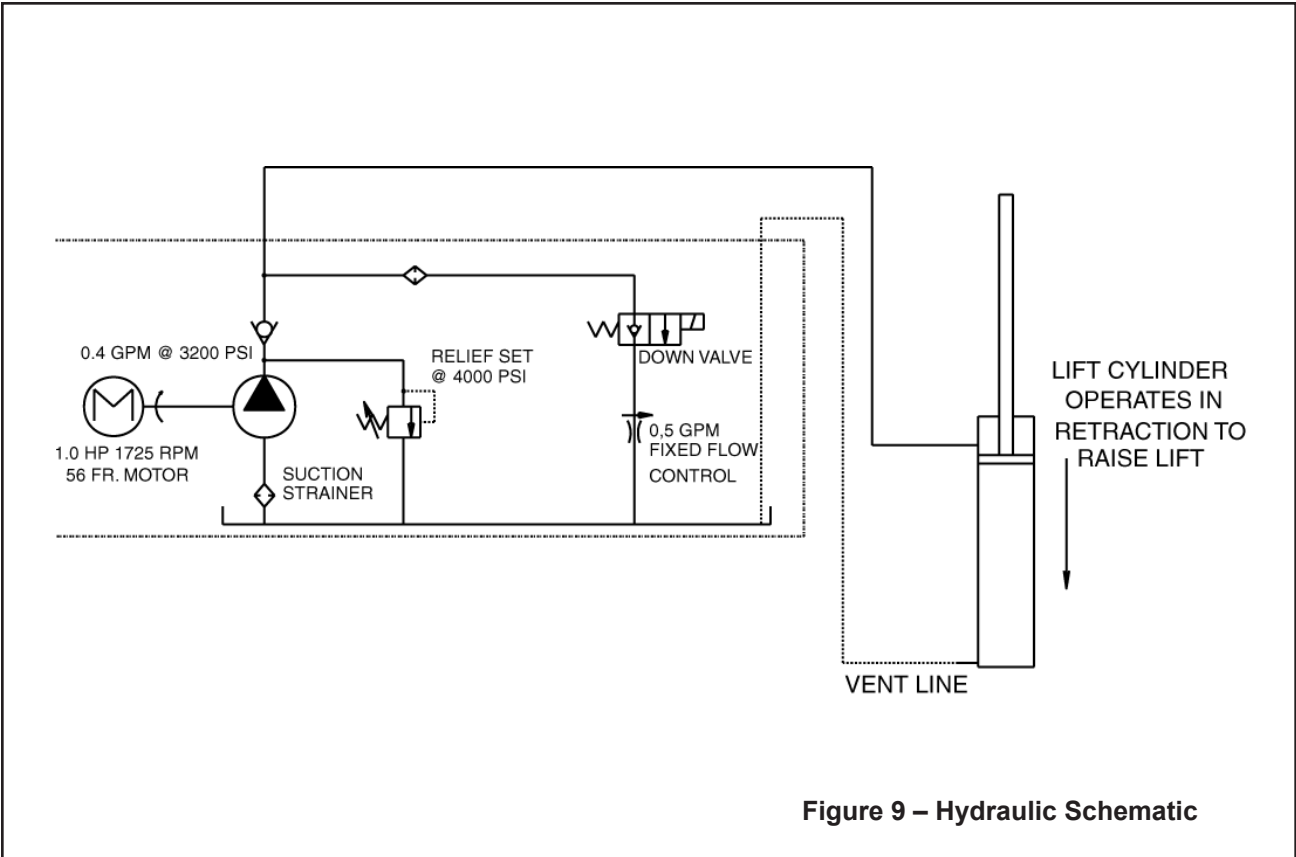

Figure 9 – Hydraulic Schematic

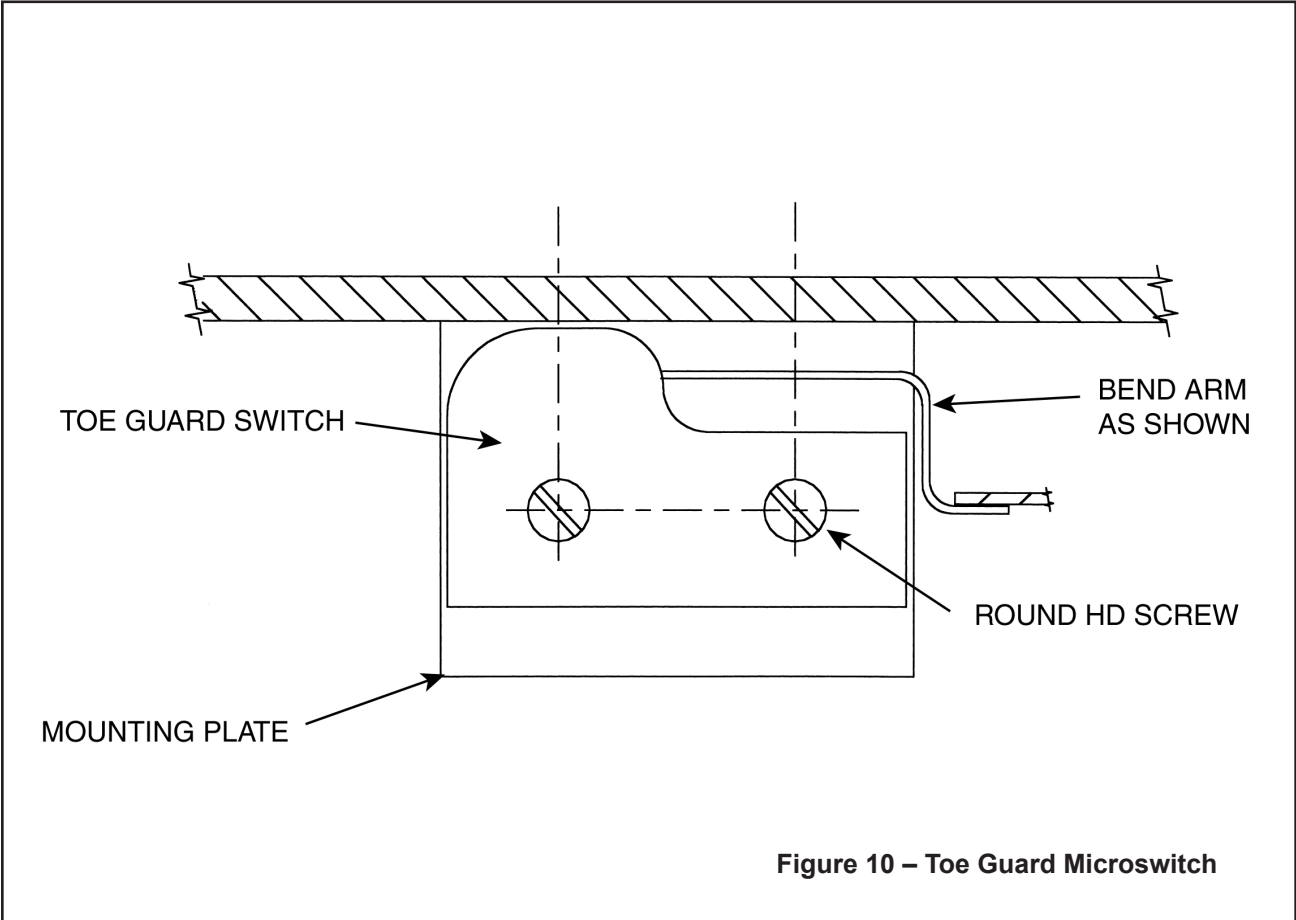

Figure 10 – Toe Guard Microswitch

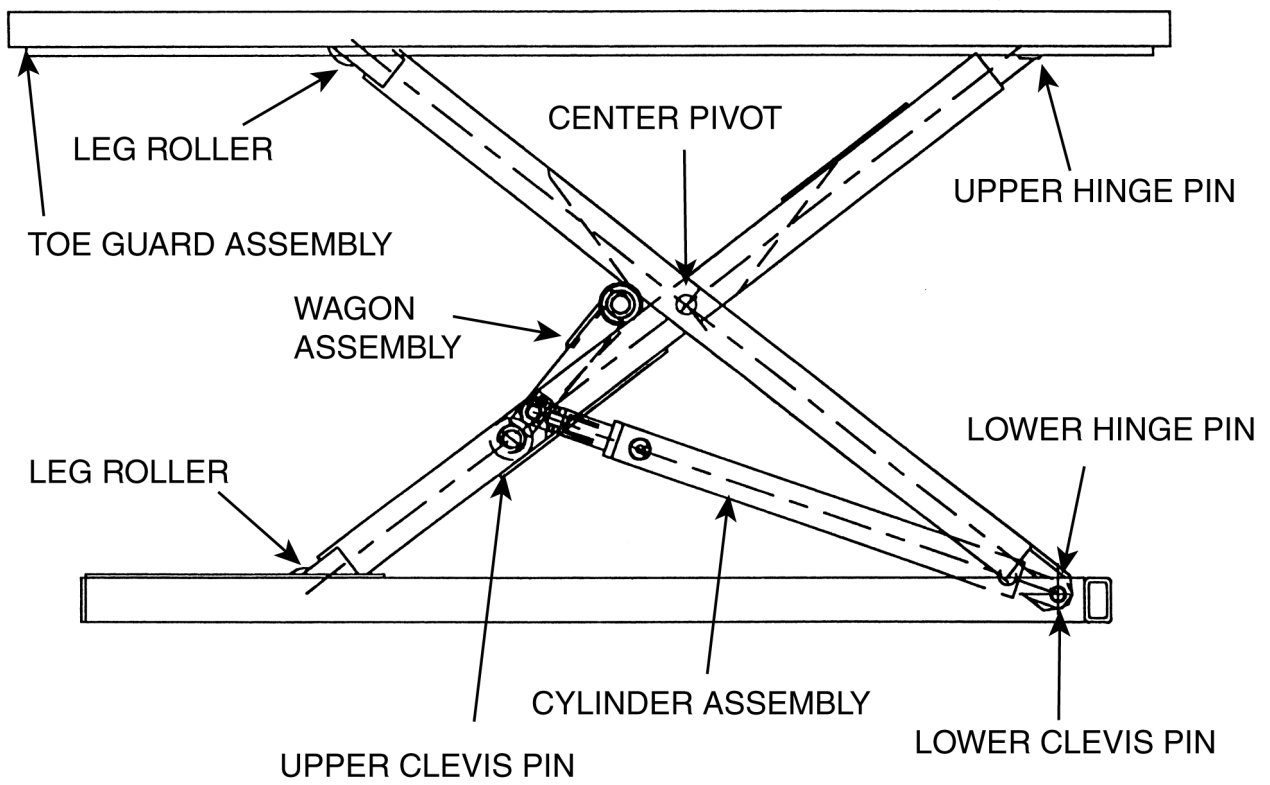
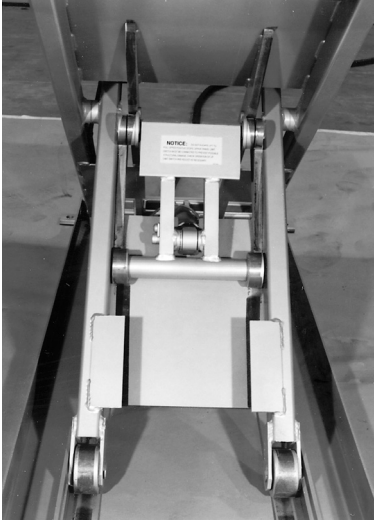
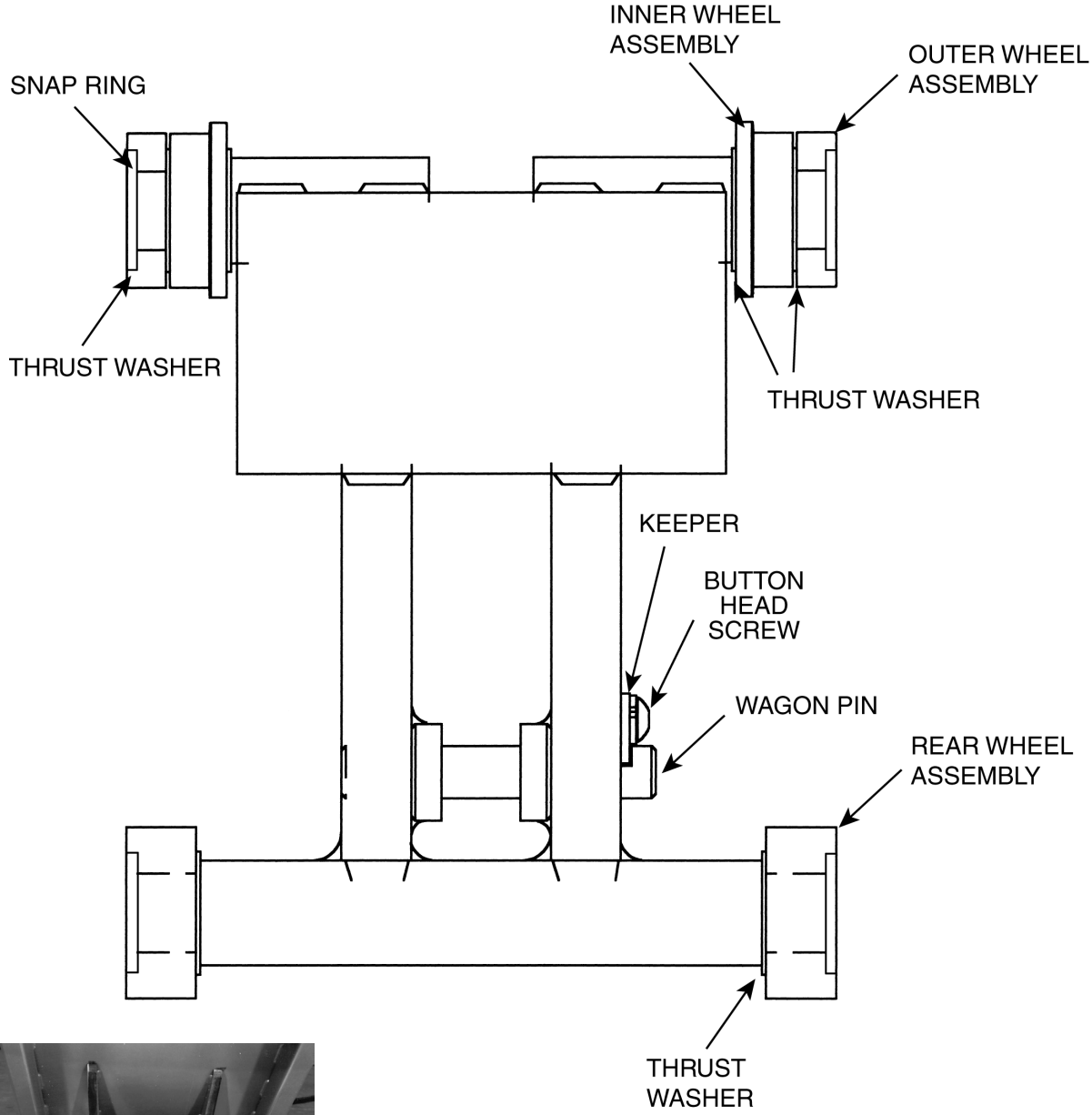

Figure 11 – LIFTMAT Assembly



Wagon Assembly Installed

Figure 12 – Wagon Assembly

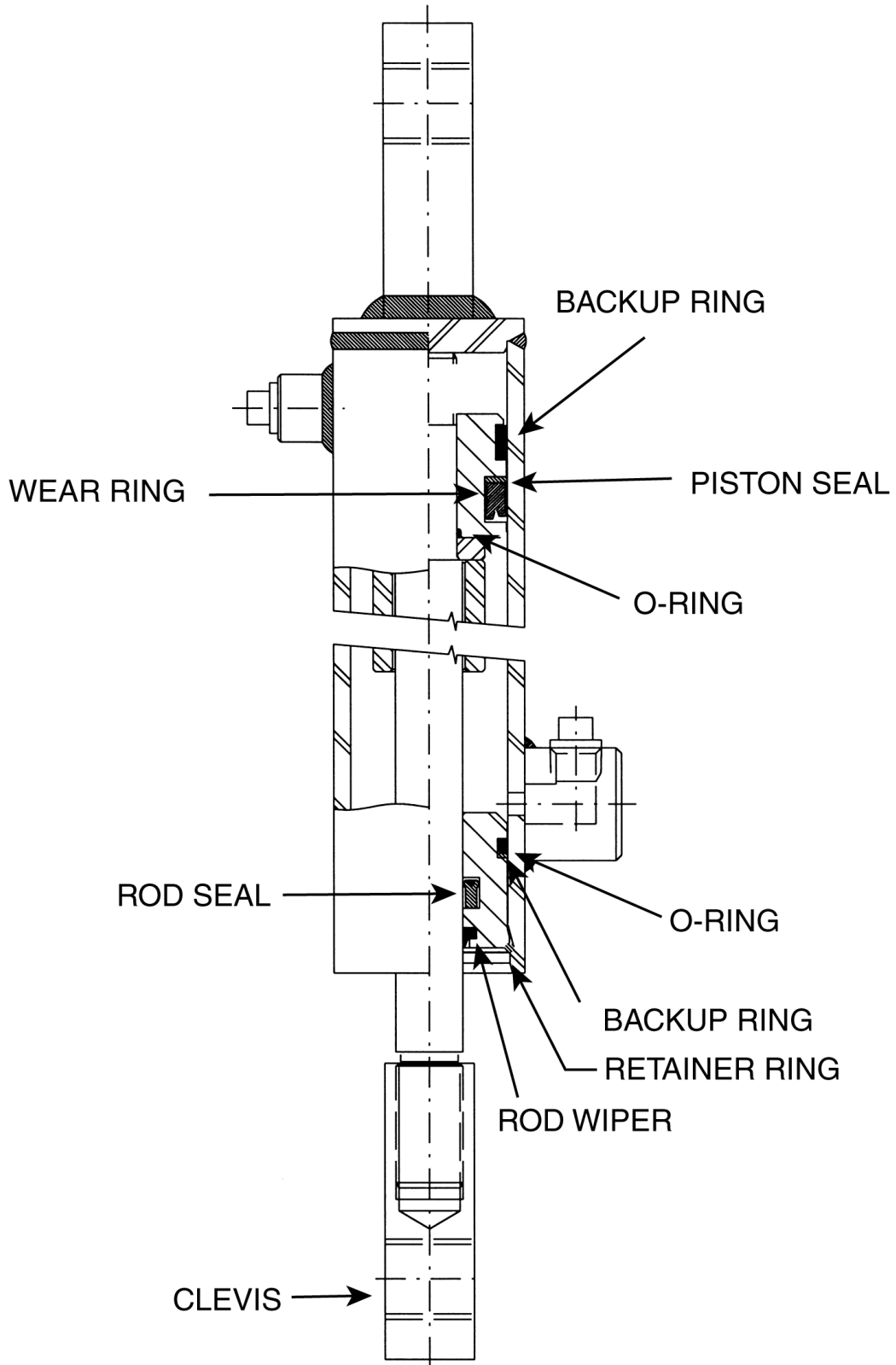
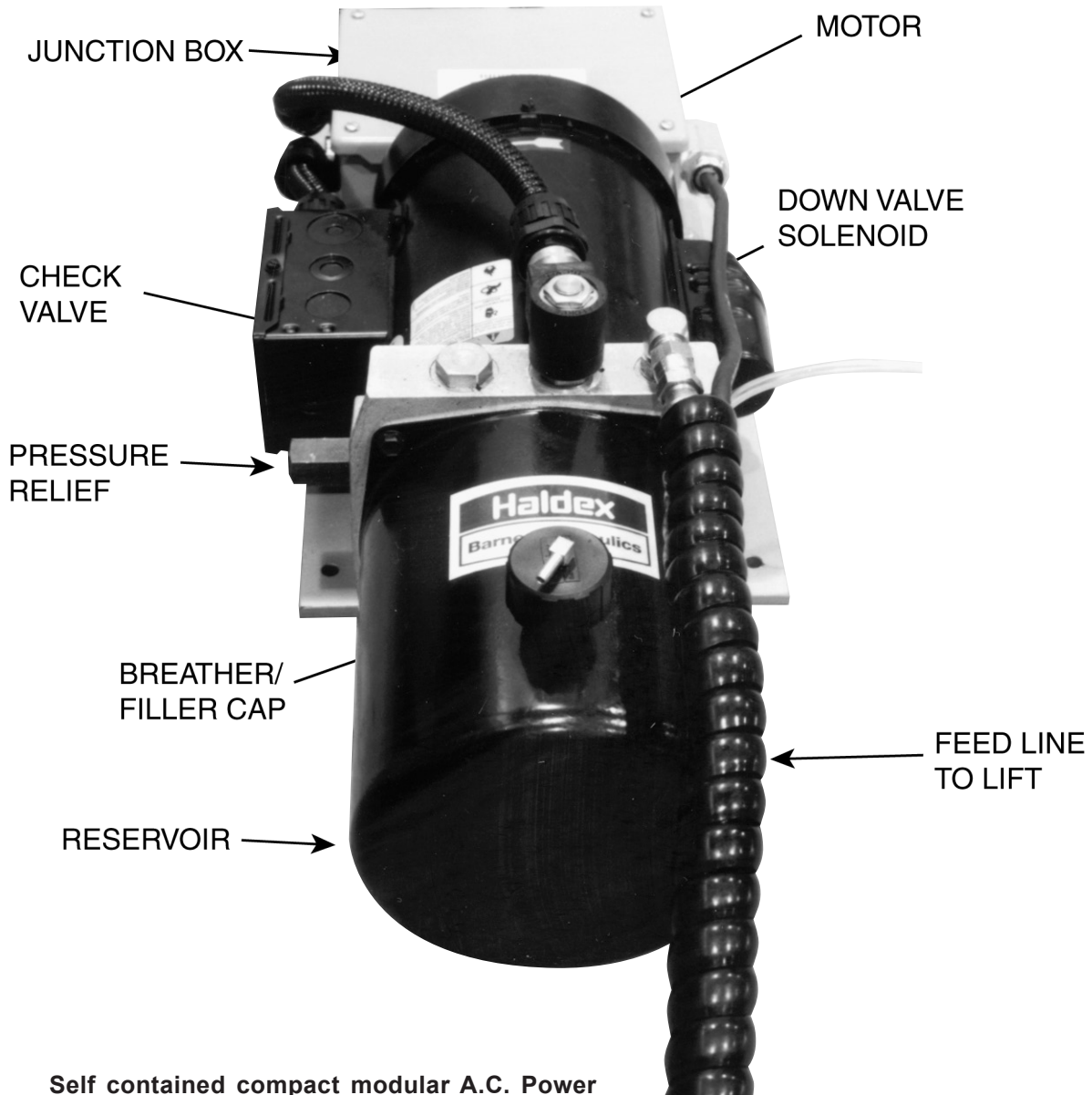

Figure 13 – Cylinder Assembly



Self contained compact modular A.C. Power Unit. 1.0 HP, 115/230 Volts, 60 Hz, Single Phase, 56 Frame, 1725 RPM, TEFC Unit delivers .4GPM @ 3200 PSI, full by-pass relief set at 4,000 PSI at 1725 RPM.

- Flow control under solenoid release valve is for 0.5 GPM fixed.

Ports: 9/16-18 SAE

1 Gallon Tank Capacity

Figure 14 – Motor Assembly

ORDERING REPLACEMENT PARTS

Southworth has carefully chosen the components in your lift to be the best available for the purpose. Replacement parts should be identical to the original equipment. Southworth will not be responsible for equipment failure resulting from the use of incorrect replacement parts or from unauthorized modifications of the machine.

Southworth will gladly supply you with replacement parts for your Southworth lift. Key parts are identified in figures 10 through 15. With your order, please include the model number and the serial number of the lift. You may find these numbers on the name plate, which is located on page 7 (fig. 5).

To order replacement parts, please call the parts Department at (207) 878-0700 or (800) 743-1000. Parts are shipped subject to the following terms:

- FOB factory
- Returns only with the approval of our parts department.
- Payment net 30 days (except parts covered by warranty).
- Freight collect (except parts covered by warranty).
- The warranty for repair parts is 30 days from date of shipment.

Parts replaced under warranty are on a “charge-credit” basis. We will invoice you when we ship the replacement part, then credit you when you return the worn or damaged part, and we verify that it is covered by our warranty. Labor is not covered under warranty for Parts orders.

Parts Department
Southworth Products Corp.

Telephone: (207) 878-0700 or (800) 743-1000

FAX: (207) 797-4734

repairparts@southworthproducts.com

2 YEAR WARRANTY

Southworth Products Corp warrants this product to be free from defects in material or workmanship for a period of **two (2) years** of single shift usage from date of shipment, providing claim is made in writing within that time period. This warranty shall not cover modified designs for special applications, failure or defective operation caused by misuse, misapplication, negligence or accident, exceeding recommended capacities, failure to perform required maintenance or altering or repairing, unless alteration is authorized by Southworth Products Corp. Except as set forth herein, there are no other warranties, express or implied, including the warranties of merchantability and fitness for a particular purpose, all of which are hereby excluded.

Southworth Products Corp makes no warranty or representation with respect to the compliance of any product with state or local safety or product standard codes, and any failure to comply with such codes shall not be considered a defect of material or workmanship under this warranty. Southworth Products Corp shall not be liable for any direct or consequential damages arising out of such noncompliance.

Southworth Products Corp's obligation under this warranty is limited to the replacement or repair of defective components at its factory or another location at Southworth Products Corp's discretion. The Southworth Warranty is for product sold with in North America. For products shipped outside of North America the warranty will be for replacement of defective parts only. Labor is not included. This is buyer's sole remedy. Except as stated herein, Southworth Products Corp will not be liable for any loss, injury or damage to persons or property, nor for direct, indirect, or consequential damage of any kind, resulting from failure or defective operation of said product.

This warranty may be altered only in writing by Southworth Products Corp, Portland, Maine.

SOUTHWORTH

SOUTHWORTH PRODUCTS CORP
P.O. Box 1380, Portland, ME 04104-1380
Telephone: 800-743-1000 / 207-878-0700
Fax: 207-797-4734
www.SouthworthProducts.com

SOUTHWORTH

making work faster, safer, and easier

Southworth is the world class supplier of products designed to improve productivity and enhance safety. Our staff has over 400 years of engineering experience. If one of our standard products does not meet your needs, our engineers can custom design equipment specifically suited to your material handling application.



Spring PalletPal Load Leveler



Lift with Flush Mount Turntable



Portable Container Tilters



Dock Lifts



Roll on Level Loaders



Portable Lifts



Stack-n-Go Powered Stacker



**Floor Height Lifts
Roll-E**

**Floor to
Mezzanine Lifts**



Pallet Rotators



For more information, contact Southworth Products

Telephone (800) 743-1000 Fax (207) 797-4734

Email: salesinfo@SouthworthProducts.com