

Operating and Maintenance Manual

PTU-4 Series E-Z Reach

4000 Lb. Capacity Portable Container Tilter

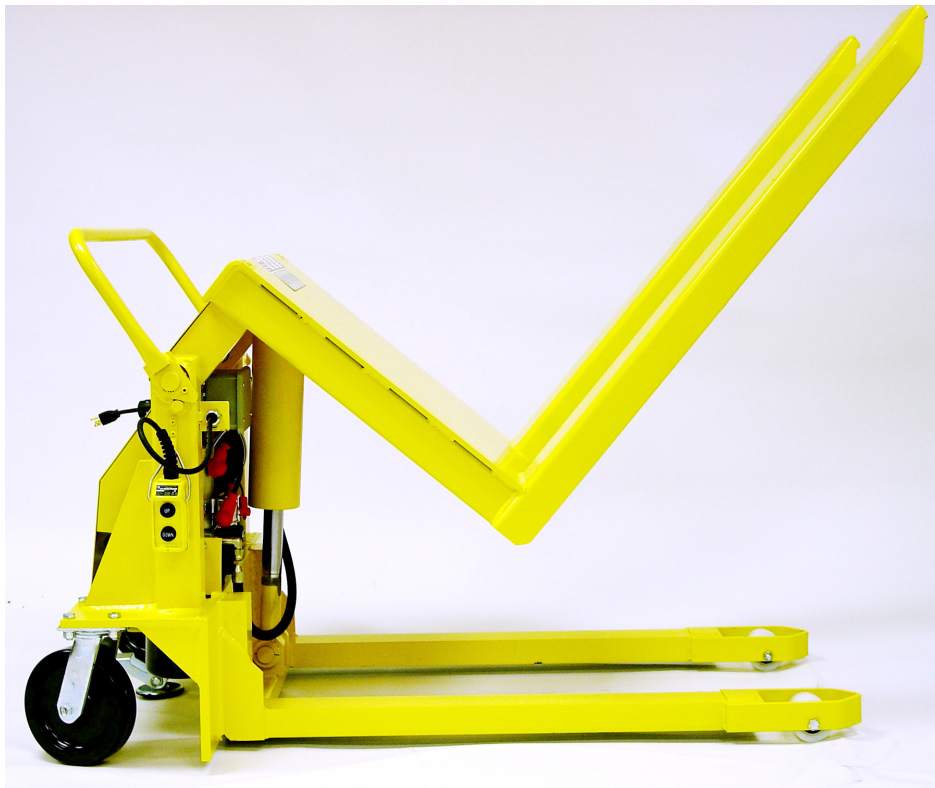

Model #: PTU-4

Serial # _____

Placed in Service _____

SOUTHWORTH

Southworth Products Corp
P.O. Box 1380 • Portland, ME 04104-1380
Telephone: 207-878-0700 Fax: 207-797-4734

June 2015

OPERATING AND MAINTENANCE MANUAL

Southworth Products Corp is widely acknowledged as the leading maker of hydraulic lifts and materials-handling equipment. Southworth machines are rugged and reliable, and are designed to provide years of trouble-free service. The designs are based on extensive engineering experience. These are good reasons for specifying Southworth machines in your plant.

Contents

INTRODUCTION	Page 4
RESPONSIBILITY OF OWNERS AND USERS	5
SAFETY	6
INSTALLATION INSTRUCTIONS	7
Preparation	7
Testing	7
Hydraulic fluid specifications	8
Changing the hydraulic fluid	8
OPERATOR INSTRUCTIONS	9
Safety Alert Symbols and Signal Words	9
Labels and Precautionary Markings	10
Loading the unit	12
Raising the tilt platform	13
Moving the unit	14
Lowering the tilt platform	14
Charging the unit	14
Precautions for grounding and AC power cord connection.....	14
MAINTENANCE	15
Hazards	15
Routine periodic maintenance	15
Repacking the cylinder	16
Troubleshooting	17
ORDERING REPLACEMENT PARTS	19
Recommended Spares	19
Warranty	23

List of Figures

Fig. 1	Labels and Precautionary Markings	10
Fig. 2	Pinch Points	11
Fig. 3a	Push the unit completely up to the load	12
Fig. 3b	Place the container up against the tilt platform	12
Fig. 4	Correct load center	13
Fig. 5	Center the load	13
Fig. 6	Don't overfill the container	13
Fig. 7	Cylinder diagram	17
Fig. 8	Hydraulic/electric diagram	18
Fig. 9	Parts Identification - Front View	20
Fig. 10	Parts Identification - Rear View	20
Fig. 11	Parts Identification - Cover Removed	20
Fig. 12	Hydraulic power unit	21
Fig. 13	Hand control	21
Fig. 14	Battery schematic.....	22

Introduction

The Southworth PTU-4 Series “EZ-Reach” Portable Tilter allows staged containers to be picked up, moved into position, and tilted for easy access.

The PTU-4 units have a maximum capacity of 4,000 lbs. These are DC-powered units, and have an on-board battery (12V unit). Once the battery has been charged, the unit can be operated without a connection to an outlet. When the battery requires recharging, the 12V unit must be connected to a battery charger.

This manual contains instructions on the safe and proper installation, use, and maintenance of a PTU-4 Series EZ-Reach unit. Be sure that this manual is available to the people who install, use, or service the unit. Be sure that all personnel read this manual before they install, use, or service the unit.

The instructions in this manual are not necessarily all-inclusive, as Southworth cannot anticipate all conceivable or unique situations. **In the interest of safety, please read this whole manual carefully. Please understand the material in this manual before you install, use, or service the E-Z Reach unit. If you have any questions about any of the instructions in this manual, please contact Southworth Products Corporation.**

Southworth’s product warranty is shown on the rear cover of this manual. This instruction manual is **not intended to be or to create any other warranty, express or implied, including any implied warranty of merchantability or fitness for a particular purpose, all of which are hereby expressly excluded.** As set forth more specifically in the product warranty, Southworth’s obligation under that warranty is **limited** to the repair or replacement of defective components, which shall be the buyer’s **sole remedy**, and Southworth shall not be liable for any loss, injury, or damage to persons or property, nor for any direct, indirect, or consequential damage of any kind resulting from the EZ-Reach Portable Tilter unit.

Responsibility of Owners and Users

Inspection and Maintenance

The device shall be inspected and maintained in proper working order in accordance with Southworth's owner's manual.

Removal from Service

Any device not in safe operating condition such as, but not limited to, excessive leakage, missing rollers, pins, or fasteners, any bent or cracked structural members, cut or frayed electric, hydraulic, or pneumatic lines, damaged or malfunctioning controls or safety devices, etc. shall be removed from service until it is repaired to the original manufacturer's standards.

Deflection

It is the responsibility of the user/purchaser to advise the manufacturer where deflection may be critical to the application.

Repairs

All repairs shall be made by qualified personnel in conformance with Southworth's instructions.

Operators

Only trained personnel and authorized personnel shall be permitted to operate the lift.

Before Operation

Before using the device, the operator shall have:

- Read and/or had explained, and understood, the manufacturer's operating instructions and safety rules.
- Inspected the device for proper operation and condition. Any suspect item shall be carefully examined and a determination made by a qualified person as to whether it constitutes a hazard. All items not in conformance with Southworth's specification shall be corrected before further use of the equipment.

During Operation

The device shall only be used in accordance with this owner's manual.

- Do not overload.
- Ensure that all safety devices are operational and in place.

Modifications or Alterations

Modifications or alterations to any Southworth industrial positioning equipment shall be made only with written permission from Southworth.

Safety

The safety of all persons installing, operating, maintaining, repairing, or in the vicinity of the PTU-4 is of paramount concern to Southworth. The PTU-4 is a powerful machine with moving parts, and is **capable of causing personal injury if proper precautions are not taken**. Therefore, throughout this manual, Southworth has identified certain hazards which may occur in the use of the PTU-4 and provided appropriate instruction or precautions which should be taken to avoid these hazards. In some cases, Southworth has also pointed out the consequences that may occur if these instructions or precautions are not followed. Southworth uses the following system of identifying the severity of the hazards associated with its products:

Signal Words: The word or words that designate a degree or level of hazard seriousness. The signal words for product safety signs are **DANGER**, **WARNING** and **CAUTION**.



Indicates an imminently hazardous situation which, if not avoided, will result in death or serious injury. This signal word is to be limited to the most extreme situations.



Indicates a potentially hazardous situation which, if not avoided, could result in death or serious injury.



Indicates a potentially hazardous situation which, if not avoided, may result in minor injury. It may also be used to alert against unsafe practices.

Please read and follow the instructions in this manual, including all safety instructions and precautions, carefully and completely.

Installation Instructions

Preparation

1. Before you start to use the unit, check for local codes and ordinances which may apply. It is your responsibility to obtain any necessary permits.
2. Read all of these installation instructions carefully. Be sure to read and understand all of the warnings.
3. The unit should only be used indoors, or it should be protected from the weather.

WARNING

- **Protect the unit from rain or moisture. If the electrical parts in the power unit get wet, workers may be hurt by electrical shock. The electrical parts may fail if they are wet.**
- **This unit has an electric motor which can create sparks. Don't use the unit in an area where flammable gases may be present.**

4. Remove the shipping material and remove the unit from the skid. You will need a crane or lift truck which can lift the unit safely.

CAUTION

Do not try to move the lift by supporting the tilt platform. One end of the tilt platform is free.

5. On the front of this manual, write down the model number, serial number, and date the unit is placed in service.
6. Before using the unit, plug it in and allow the battery to charge overnight.
7. Check the level of the hydraulic fluid in the tank. In order to check the level, lower the tilt platform completely and unplug the power cord. Remove the rear cover on the unit. Open the filler cap on the side of the power unit. The fluid should reach the elbow in the filler pipe. Do not fill to the top of the filler pipe – there should always be an air space at the top of the tank.

8. Be sure the tank vent is not plugged. Before operating the unit, you must remove the solid plug from the top of the tank and insert the red plastic vented plug. Also check to be sure the vent line is clear.

Testing

1. Be sure the battery is charged. (See page 10, Charging the Unit.) Clear the area around the unit, and warn others to stay away from the unit.
2. Operate the unit through its full range of travel. The unit should rise smoothly with a quiet humming sound, and lower smoothly and quietly. Raise and lower the unit a few times to check the lifting action.

WARNING

As the tilt platform moves up and down, “pinch points” are created at the places shown in Fig. 2. If you are standing too close to the unit when it is moving, your arm or leg may be caught in the moving parts, and you may be hurt. Stay away from the pinch points when the unit is moving.

3. Test the unit with the rated load. If the unit does not rise, and you hear a loud squealing noise, the pressure relief valve is operating. Contact Southworth for instructions.

WARNING

Don't continue to use the unit if this happens – the pump will overheat very quickly, and may be permanently damaged. Do not try to adjust the relief valve. If you change the setting on the relief valve, you may overwork the unit. This can cause the unit to fail suddenly, and you may be hurt.

4. Clean up any spilled hydraulic fluid. Spilled hydraulic oil is slippery, and may present a fire hazard. If you clean up any spilled fluid, you will be able to tell right away if the unit begins to leak.
5. Figure 1 shows the safety labels on this unit. Check to be sure all of the labels are in place. For complete label locations, see page 6.

Hydraulic Fluid Specifications

If the EZ-Reach unit will be used at normal ambient temperatures, Southworth supplies the lift with Dextron 3 ATF. This may be replaced by any other good-quality oil with 150 SSU at 100° F and rust and oxidation inhibitors and anti-wear properties.

If the EZ-Reach unit will be used at ambient temperatures below 0° F, use aircraft hydraulic oil. Use Texaco type BB or an equivalent.

The following are equivalent to Dextron 3 ATF:

<u>TYPE</u>	<u>MANUFACTURER</u>
D.T.E. 24	MOBIL OIL CO.
NUTO H32	EXXON CO.
AMOCO AW32	AMOCO CO.
Citgo AW32	CITGO OIL CO.

CAUTION

It is very important to keep the hydraulic oil free of dirt, dust, metal chips, water, and other contamination. Most problems with hydraulic systems are caused by contamination in the oil.

Changing the Hydraulic Fluid

In order to change the fluid, lower the tilt platform completely and remove the rear cover on the unit.

To change the fluid, you must remove the power unit from the machine. Disconnect the electrical wiring, the hydraulic hose, and the vent line. Once the power unit has been removed, you can remove the filler cap and pour out the old fluid. Fill with fresh fluid up to the elbow in the filler pipe. Do not fill to the top of the filler pipe – there should always be an air space at the top of the tank.

CAUTION

As you disconnect the hydraulic lines, be sure to keep them free of dirt or contamination.

OPERATOR INSTRUCTIONS

SAFETY ALERT SYMBOLS AND SIGNAL WORDS

The safety of all persons operating, maintaining, repairing, or in the vicinity of this equipment is of paramount concern. This is a powerful machine with moving parts, and is capable of causing personal injury if proper precautions are not taken. Therefore, throughout this manual, certain hazards have been identified which may occur in the use of the machine, and there are appropriate instructions or precautions which should be taken to avoid these hazards. In some cases, there are consequences which may occur if instructions or precautions are not followed. Below are the symbols and signal words along with their definitions referenced from ANSI Z535.4 - Product Safety Signs and Labels.

Safety Alert Symbols

These are the safety alert symbols.. They are used to alert you to potential physical injury hazards. Obey all safety messages that follow this symbol to avoid possible injury or death.



For use with **DANGER** signal word
(Red Background)



For use with **WARNING** signal word
(Orange Background)



For use with **CAUTION** signal word
(Yellow Background)

Signal Words

The meaning of different signal words as defined by ANSI Standard Z535.4 indicates the relative seriousness of the hazardous situation.



(Red Background)

DANGER indicates a hazardous situation which, if not avoided, will result in death or serious injury.



(Orange Background)

WARNING indicates a hazardous situation which, if not avoided, could result in death or serious injury.



(Yellow Background)

CAUTION, used with the safety alert symbol, indicates a hazardous situation which, if not avoided, could result in minor or moderate injury.



(Blue Background)

NOTICE is used to address practices not related to personal injury.



(Green Background)

SAFETY INSTRUCTIONS (or equivalent) signs indicate safety-related instructions or procedures.

OPERATING AND MAINTENANCE MANUAL

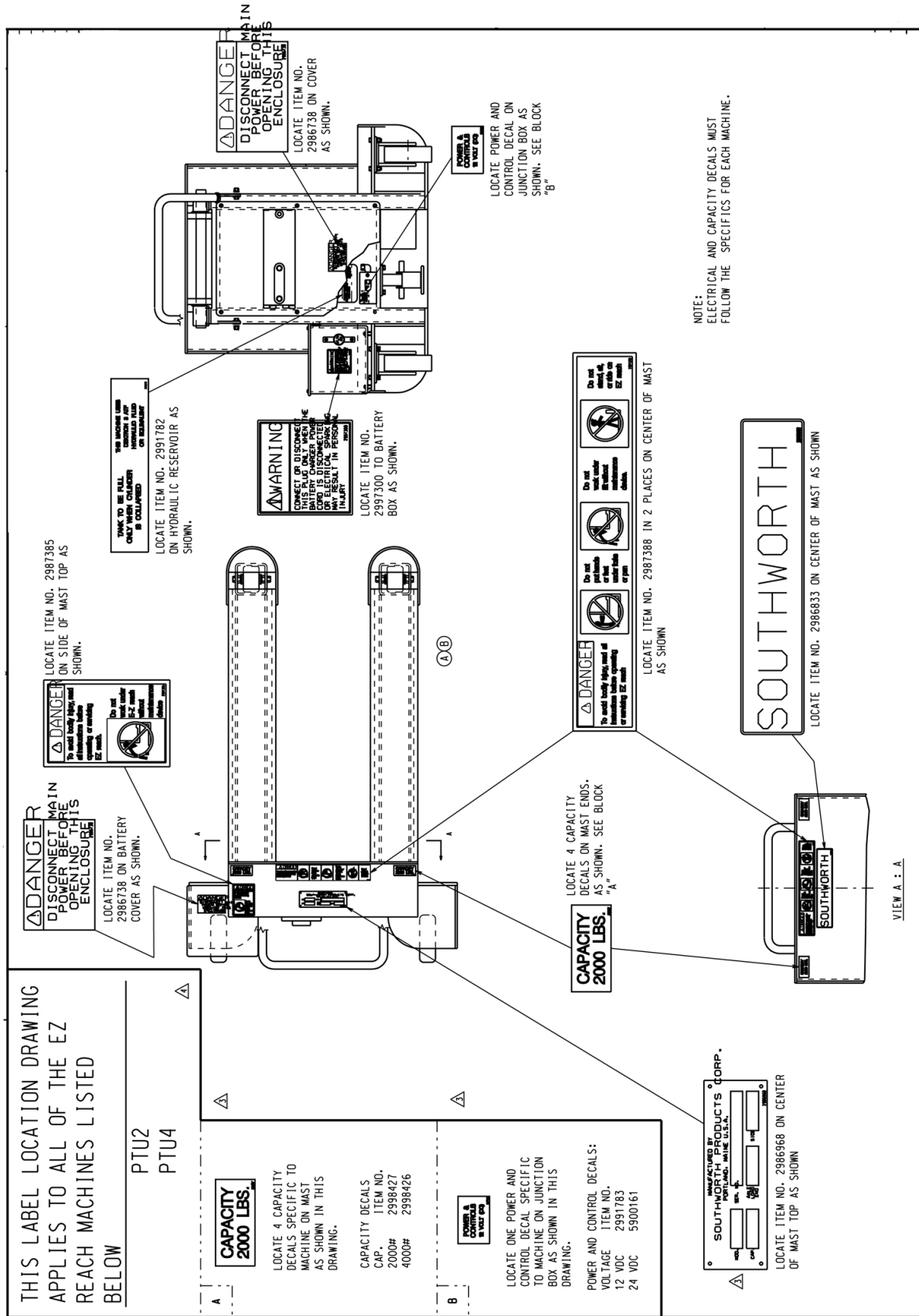

Figure 1. Safety Labels

Operating Instructions

Safety Instructions

⚠️ WARNING

- To avoid bodily injury, please read all instructions before operating or servicing the unit.
- Do not work under the tilt platform when it is raised. Before servicing the unit, always lower the unit and unplug the power cord. Remember that the battery is still connected, and can still provide power to the unit.
- Never put your hands or feet under the tilt platform.
- As the unit is operating, stay away from the moving parts shown in Fig. 2.
- Do not stand, sit or ride on the tilt platform.
- Before raising or lowering the tilt platform, always set the floor lock so the unit cannot roll out of position.

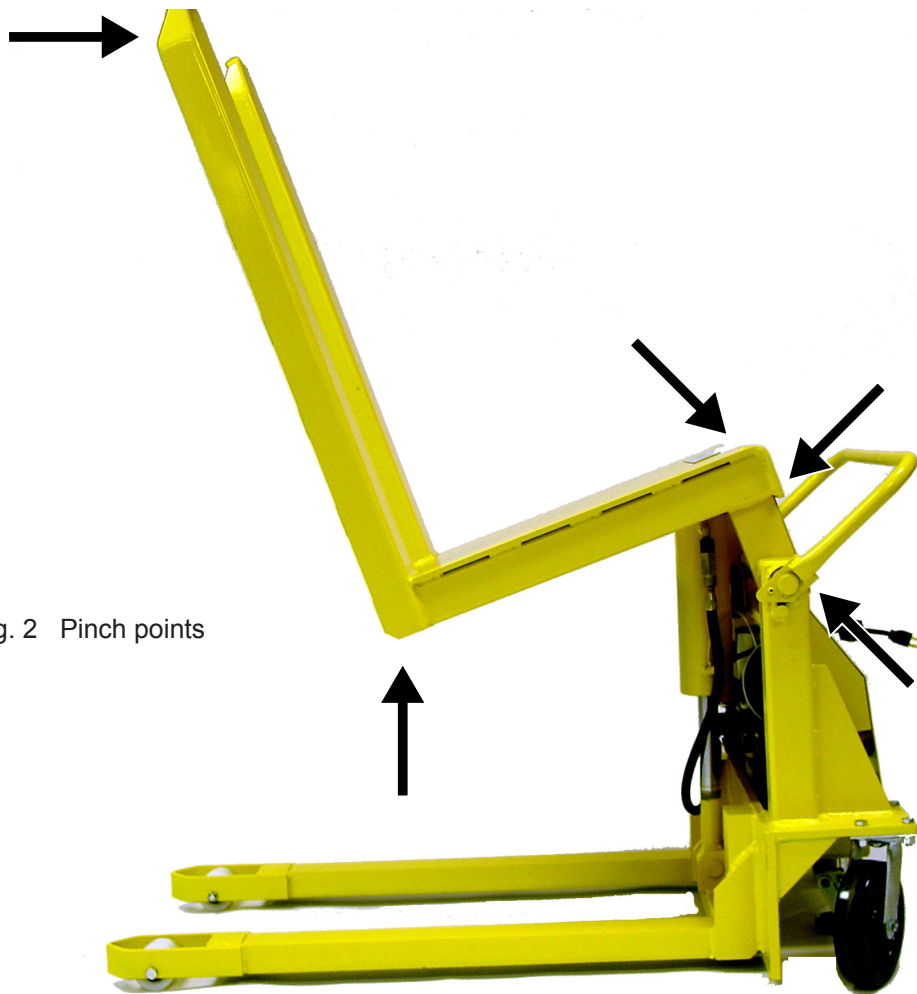

Fig. 2 Pinch points

Loading the unit

1. Before operating the unit, please read and understand all of this section.
2. Load the unit correctly.

Before lifting, push the lifting arms of the unit completely under the load so that no space is left between the load and the tilting platform, as shown in Fig. 3a. If you do not do this, the container may slide down and create dangerous "pinch points."

Be sure that the load weighs no more than the maximum rated for the unit. The maximum rated load is listed on the data plate. Remember that the lifting container may weigh 75 lbs. or more.

WARNING

The tilt platform should always be pushed against the load. If the load is placed far out on the lifting arms, the unit may not be able to lift the full rated load safely. See Fig. 4. (The unit is designed so that the center of load should be 17" from the bottom of the tilt platform, and 20" from the face of the platform.)

WARNING

Don't try to lift a load that exceeds the maximum rating. Only lift a load if the center of load is within the allowable range. If you do not follow these rules, the unit may fail suddenly. Someone may be hurt, and the unit and load may be damaged.

3. The load should be balanced in the side-to-side direction. Whenever possible, place the load in the center of the tilting platform, as shown in Fig. 5. If the load is off-center on the pallet, place the heaviest part of the load near the back of the tilt platform – never near the front!

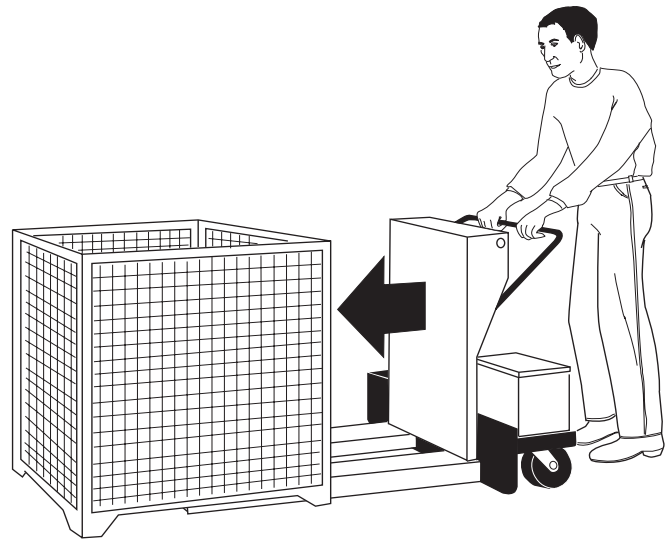

Fig. 3a Push the Unit Completely Up to the Load

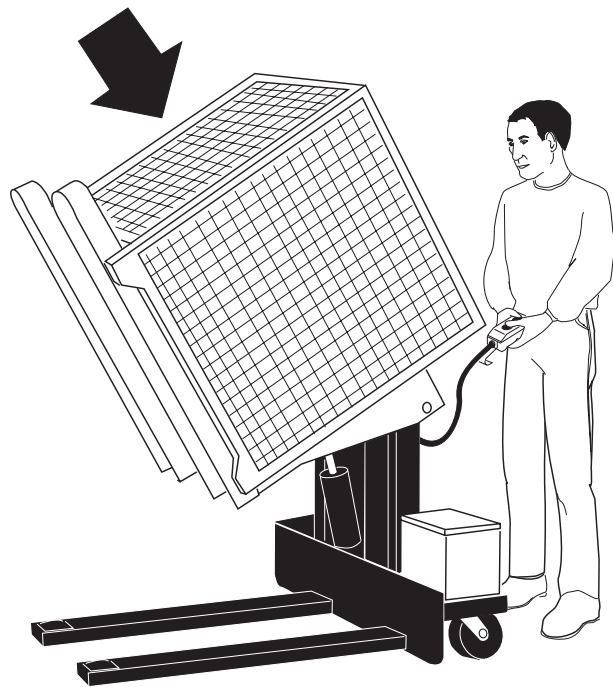

Fig. 3b Before lifting make sure the container is pushed up against the tilt platform.

4. Sometimes the unit may be used to lift parts which can roll. If possible, stack the parts in the parts container so they cannot roll. Do not over-fill the lifting container. See Fig. 6. If the container is too full, some of the parts may roll out of the front of the container.

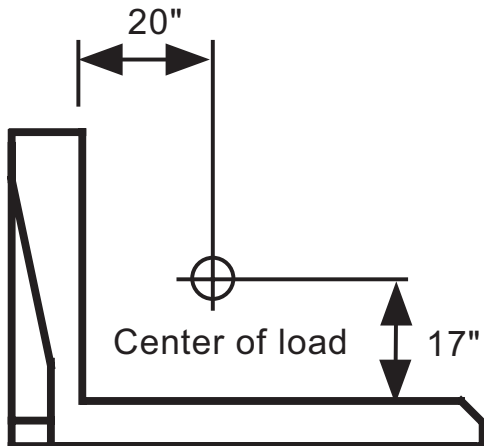

Fig. 4 Correct Load Center

Raising the Tilt Platform

1. Before raising the tilt platform, be sure all workers are clear of the unit.

WARNING

As the tilt platform moves up and down, “pinch points” are created as shown in Fig. 2. Stay away from these pinch points! Part of your body or clothing may become caught, and you may be hurt. Do not put your hands or feet under the tilt platform. Do not stand or sit on the tilt platform.

2. Before lifting, set the floor lock. This will keep

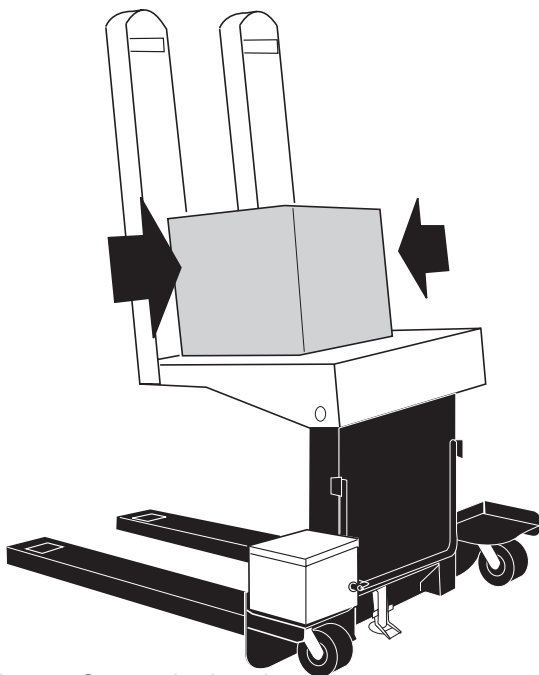

Fig. 5 Center the Load

the unit in position so that it cannot move accidentally.

3. Before lifting, be sure the parts container is pushed up against the tilt platform, as shown in Fig. 3b. Be sure the load is balanced side-to-side, as shown in Fig. 5.
4. Operate the unit. Press and hold the Up button to raise the tilt platform, and Down to lower it. If the unit does not operate right away, call a qualified maintenance worker.

WARNING

If you hear a squealing noise from the pump, the pressure relief valve is operating. Don't continue to use the unit! The pump will overheat very quickly, and may be permanently damaged. The relief valve is included to protect the machine operators. Do not change the setting on the relief valve. If you do change the setting, this may cause a hydraulic part to fail. The tilt platform may drop suddenly. Someone may be hurt, and the unit and load may be damaged. The hydraulic parts in the unit are designed to handle a certain

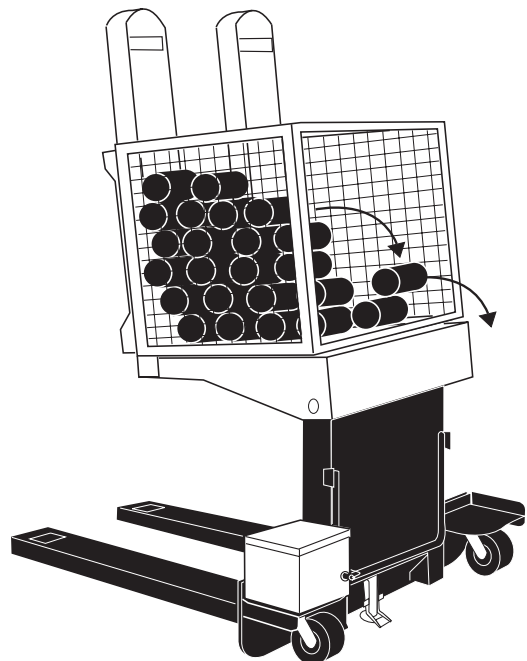

Fig. 6 Don't Over-Fill the Container

amount of pressure. The relief valve has been included for the protection of all of the workers who use the unit.

Moving the Unit

1. Before moving the unit, always lower the tilt platform to the lowest possible level. You should do this even if the unit is not loaded.

⚠ WARNING

If you try to move the unit while the tilt platform is raised more than a few inches, the unit may be unstable. You may be hurt, and the lift or load may be damaged.

2. Before moving, release the floor lock.
3. Always roll the unit across a stable, solid surface.

⚠ WARNING

If the floor is not stable or solid, the unit may tilt over. You may be hurt, and the unit or load may be damaged.

Lowering the Tilt Platform

1. Before lowering the tilt platform, be sure the floor lock is set. This will keep the unit from moving accidentally.

2. Before lowering the tilt platform, be sure all workers are clear of the unit.

⚠ WARNING

As the tilt platform moves up and down, “pinch points” are created as shown in Fig. 2. Stay away from these pinch points! Part of your body or clothing may become caught, and you may be hurt.

3. Press the Down button to lower the tilt platform. The tilt platform should lower at a uniform speed.

Charging the Unit

1. The battery power system is designed for intermittent duty. The unit is not designed to operate continuously. If fully-charged, the battery should operate the unit for about 30 lift cycles per charge. The battery should require about 4 hours minimum to recharge completely.
2. To begin charging, plug in the 115V power cord for the battery charger. A red light on the charger indicates charging. A green light will light up when fully charged.

PRECAUTIONS FOR GROUNDING AND AC POWER CORD CONNECTION

Charger should be grounded to reduce risk of electric shock. Charger is equipped with an 115V electric cord having an equipment-grounding conductor and grounding plug. The plug must be plugged into an outlet that is properly installed and grounded in accordance with all local codes and ordinances.

⚠ DANGER

Never alter the AC cord or plug provided. If it will not fit outlet, have proper outlet installed by a qualified electrician. Improper connection can result in a risk of an electric shock.

Maintenance

All servicing should be done by qualified personnel. Qualified personnel should be able to read and understand wiring and hydraulic diagrams. They should be able to troubleshoot live electrical circuits safely and in accordance with accepted practice. **For safety's sake**, if in doubt, please contact your dealer or Southworth Products Corporation Customer Service Department at (207) 878-0700.

Before servicing the unit, please read and understand all of this section and the section entitled "Operating Instructions."

Hazards

There are several hazards you should be aware of as you service the unit:

WARNING

- **As the unit moves up and down, "pinch points" are formed as shown in Fig. 2. Keep hands, feet, and loose clothing away from these pinch points. If your hand or arm or a part of your clothing is caught, you may be hurt.**
- **Before performing any maintenance on the unit, lower the tilt platform completely. Failure to do so could result in severe personal injury.**
- **The relief valve has been included for the protection of all of the workers who use the unit. Don't change the relief setting! If the relief valve does not open when it should, the unit may fail. Someone may be hurt, and the unit and load may be damaged.**
- **If the hydraulic fluid is released under high pressure, it can cause personal injury. Before you open any part of the hydraulic system, be sure to release the hydraulic pressure. You can do this by lowering the tilt platform all the way down.**
- **The warning labels have been included for the safety of the operator.**

If the labels are worn or missing, or have been painted over, replace them before releasing the lift for operation. Fig. 1 shows the safety markings on this unit.

Routine Periodic Maintenance

Every month:

- Visually inspect the pins and bushings on the cylinder for signs of wear. Also check the pivot pins at both sides of the tilt platform. If any of these parts are worn, replace as needed.
- Apply light oil or WD-40 to the parts listed in the last step.

Note – Although the bushings are "lifetime lubricated" Teflon® bushings, their performance may be extended by additional periodic lubrication.

- Check the hydraulic oil level. In order to check the level, lower the tilt platform completely and unplug the power cord. Remove the rear cover on the unit. Open the filler cap on the side of the power unit. The fluid should reach the elbow in the filler pipe. Do not fill to the top of the filler pipe - there should always be an air space at the top of the tank.

CAUTION

It is important to use hydraulic fluid with the correct grade and properties. See the hydraulic oil specification in this section of this manual.

Every six months or 500 hours of operation, whichever comes first:

- Check all of the hydraulic fittings and hoses, and tighten the connections if necessary. Sometimes the fittings can be worked loose by the vibrations from the power unit.

WARNING

If a hydraulic fitting becomes loose, or if a hydraulic hose breaks, the hydraulic fluid may escape from the system under pressure. If the tilt platform is raised when this happens, it can drop

quickly. Someone may be hurt, or the unit or load may be damaged. To avoid this problem, inspect all of the hydraulic hoses and fittings regularly, and replace them if they are worn or damaged.

- The clear plastic vent line and the cylinder rod should be free of hydraulic fluid. If you find much fluid in either place, the cylinder seals may be leaking. (It is also possible the tank may be over-filled.) If the worn parts must be replaced, see the section on “Repacking the Cylinder.”
- Disassemble the down valve. Blow the valve plunger clean with compressed air. Reassemble the valve and reinstall it.
- Drain and discard the hydraulic fluid. The suction filter is in the tank, at the point where the suction line runs out to the pump. Unscrew the hydraulic line, then remove the filter. Blow the filter clean with compressed air. Reinstall the filter in the tank and reassemble the hydraulic line.
- Refill the tank with new hydraulic fluid.



If you continue to use fluid after it has “worn out,” the moving parts in the system will wear more quickly.

Repacking the Cylinder

1. Remove the cylinder from the machine. Clean the outside of the cylinder. Push the piston into the cylinder as far as possible. Drain the oil from the cylinder. Clear an area near the cylinder so that you can lay out the parts as you remove them.
2. Secure the cylinder in a vise, or use another method to keep it from rotating.
3. Using snap ring pliers or a screwdriver, remove the snap ring from the gland of the cylinder. Pull the rod out to within 3 to 6 inches of full extension. Compress the ring and, at the same time, pull the rod and drive the gland out of the cylinder.
4. Carefully remove the rod assembly from the cylinder and remove the gland. Slip the gland over the end of the rod. Be careful not to damage the finish on the rod.
5. Carefully examine the seals on the piston and gland. Remember the positions of these parts so that you can place the replacement parts correctly. Notice that the lip on the rod wiper faces upward. Remove all seals from the piston and gland.
6. Inspect the parts for damage - nicks, scratches, cracks, etc.
7. Install new seals on the piston and gland. Be sure that all parts are free of dirt or contamination. Install the snap ring on the gland.
8. Coat the inside diameter of the gland with light grease and replace it on the rod.
9. Coat the outside diameter of the piston and seal area on the gland with light grease. Apply a light coat of hydraulic oil to the inside diameter of the cylinder. Insert the rod assembly into the cylinder. Be careful not to damage the threads, rod, or seals.
10. Rotate the gland so that the port for the hydraulic oil lines up with the hole in the side of the cylinder. Compress the snap ring and lightly tap the gland into place. Relax the snap ring. **Be sure that the snap ring is seated in the groove.** If the snap ring is not seated, the gland may pop out of the end of the cylinder under pressure.
11. Install the cylinder in the machine and test it. Operate the cylinder through several complete cycles to work out any air bubbles in the hydraulic fluid.

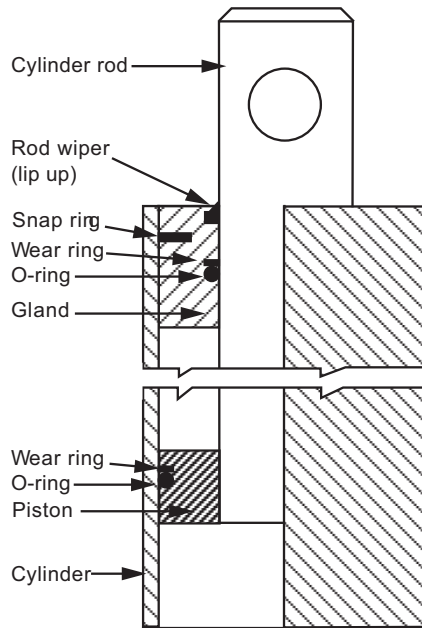

Fig. 7
Cylinder Diagram

this may cause a hydraulic part to fail. The tilt platform may drop suddenly. Someone may be hurt, and the unit and load may be damaged. The hydraulic parts in the lift are designed to handle a certain amount of pressure. The relief valve is set to relieve this pressure before it becomes too great. The relief valve has been included for the protection of all of the workers who use the unit.

CAUTION

If cavitation is allowed to continue, the pump may be damaged, and may have to be replaced.

Troubleshooting

All servicing should be done by qualified personnel. Qualified personnel should be able to read and understand wiring and hydraulic diagrams. They should be able to troubleshoot live electrical circuits safely and in accordance with accepted practice. **For safety's sake**, if in doubt, please contact Southworth Products Corporation at (207) 878-0700.

Before servicing the unit, read and understand this entire section and the section entitled "Operating Instructions."

WARNING

Before performing any maintenance on this unit, lower the tilt platform completely.

CAUTION

If the platform will not raise, do not continue to hold the Up button for more than 2 or 3 seconds. You may damage the pump.

WARNING

Don't change the setting of the relief valve. If you do change the setting,

OPERATING AND MAINTENANCE MANUAL

Problem	Possible Cause	Check This
Tilt Platform will not raise	Battery may need charging	Battery volt level
		Is the charger putting out 12 volts?
		Check that 12 volts is being reached at the motor & motor relay
		Is the charger operating properly?
	Load is too heavy	Verify the load weight
	Unit is low on oil	Inside the tank, make sure the oil is full to the elbow in the filler pipe.
Tank vent may be plugged.	Suction filter may be clogged.	Look to see that the solid plug is not in place of the vent plug.
		Remove and clean the suction filter.
Unit elevates but will not hold a load	Down valve coil may be energized.	Remove the down valve and ensure it is not being energized when the up button is pushed. Check wiring to the down valve.
		Ensure debris is not holding the down valve plunger open.
	Cylinder may be leaking	Check the vent line for signs of oil
Unit fails to lower	Down valve coil may not be energized	Make sure the coil is energized when the down button is pushed.
		Ensure the down valve itself is shifting and allowing oil to go back to the tank (do not remove this under pressure)
		Check that nothing is binding causing the unit not to lower.

If the steps listed above do not solve the problem, please call the Southworth Products Corp Customer Service Department at (207) 878-0700.

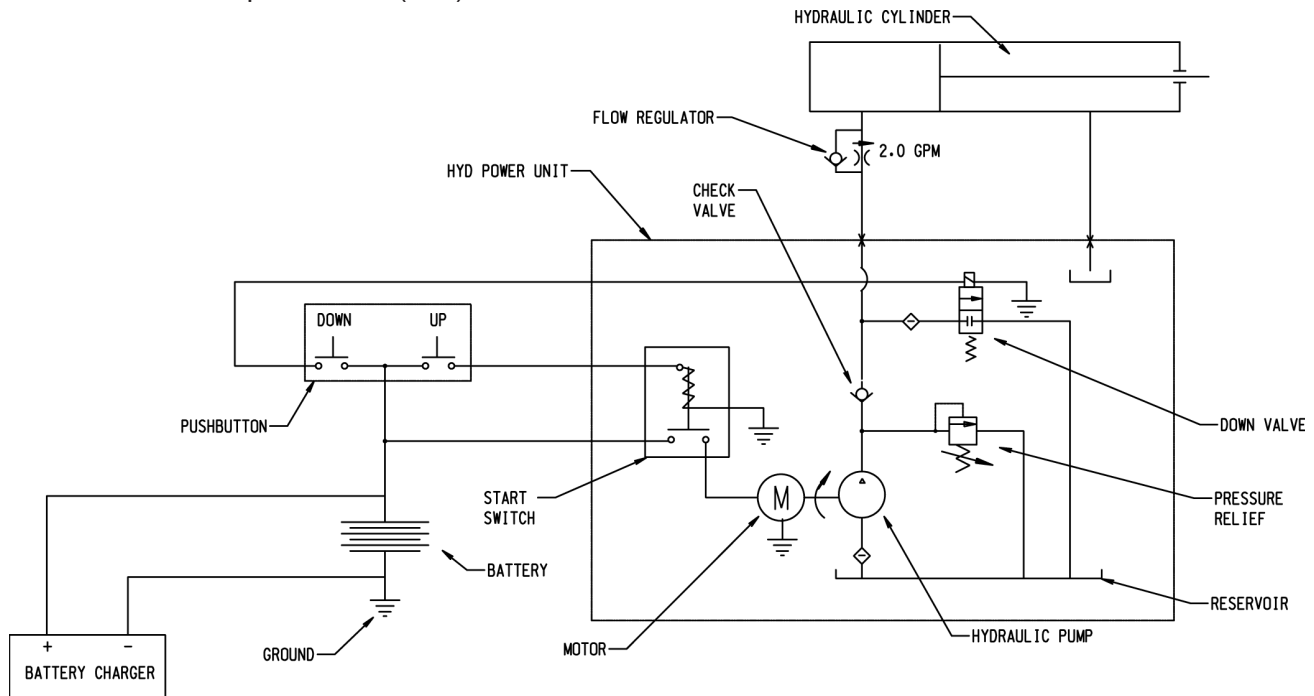

Fig. 8 Hydraulic/Electrical Diagram

Ordering Replacement Parts

Southworth has carefully chosen the components in your unit to be the best available for the purpose. Replacement parts should be identical to the original equipment. Southworth will not be responsible for equipment failures resulting from the use of incorrect replacement parts or from unauthorized modifications to the machine.

Southworth can supply all replacement parts for your Southworth lift. With your order, please include the model number and the serial number of the unit. You will find these numbers on the name plate.

To order replacement parts, please call the Parts Department at (207) 878-0700. Parts are shipped subject to the following terms:

- FOB factory.
- Returns only with the approval of our parts department.
- Payment net 30 days (except parts covered by warranty).
- Freight collect (except parts covered by warranty).
- The warranty for repair parts is 30 days from date of shipment.

Parts replaced under warranty are on a “charge-credit” basis. We will invoice you when we ship the replacement part, then credit you when you return the assumed substandard part, and we verify that it is covered by our warranty. Labor is not covered under warranty for Parts orders.

Parts Department
Southworth Products Corp
P.O. Box 1380
Portland, ME 04104-1380
Telephone: (207) 878-0700
FAX: (207) 797-4734
repairparts@SouthworthProducts.com

Recommended Spares

<u>Item No.</u>	<u>Description</u>	<u>Quantity</u>
2989419	Flow Control	1
3041942P	Power Unit 12VDC	1
1004-021A	Front Wheel	2
10027653	Rear Wheel	2
2997783P	Floor Lock	1
C141E	Battery	1

OPERATING AND MAINTENANCE MANUAL

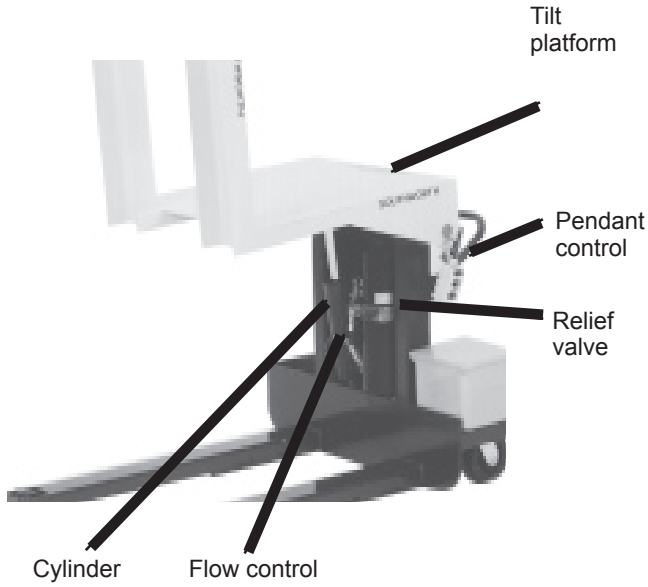

Fig. 9 Parts Identification, Front View

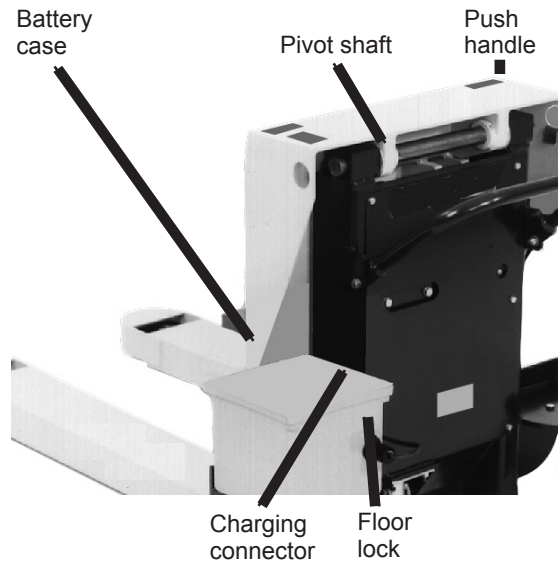

Fig. 10 Parts Identification, Rear View

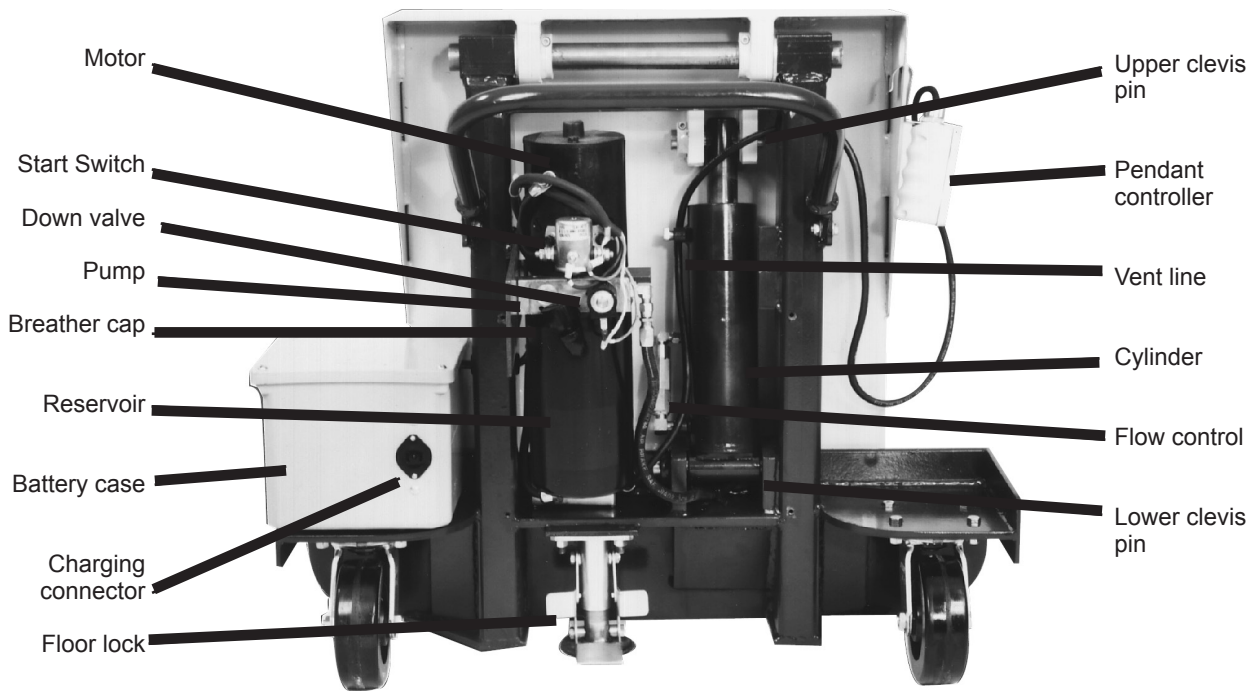
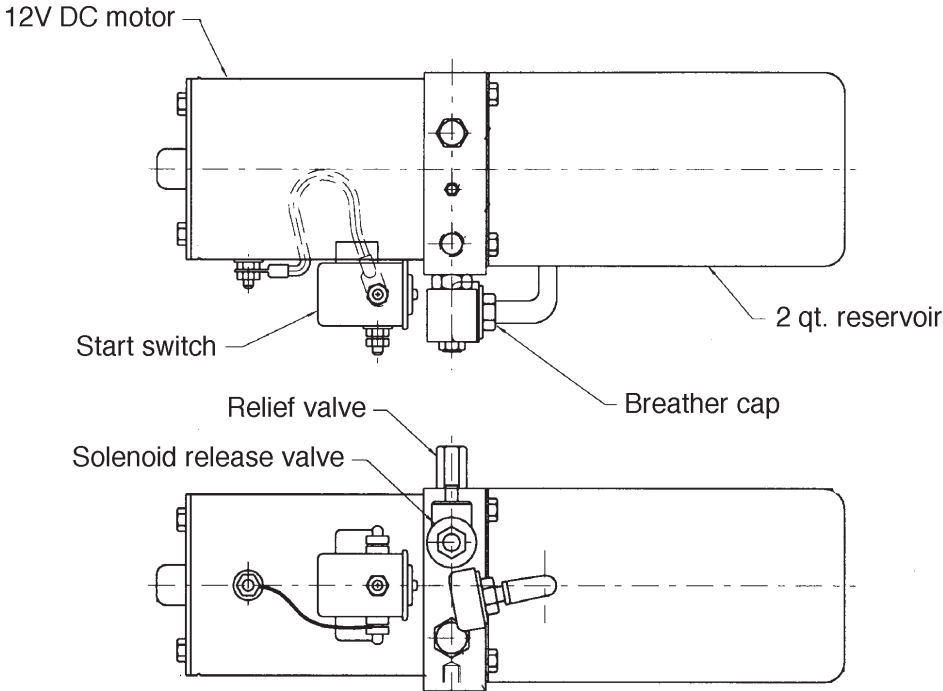
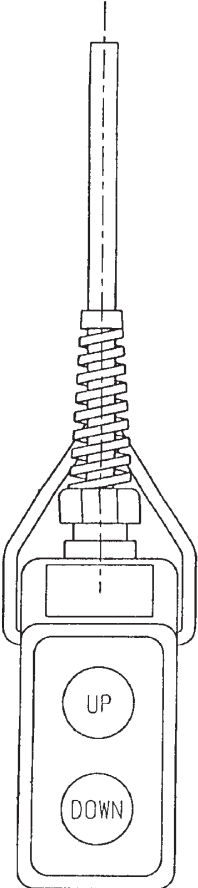

Fig. 11 Parts Identification, Cover Removed



Southworth part no. C-3041942P

Fig. 12
Hydraulic Power Unit



Southworth part no. B-3053047P

Fig. 13
Hand Control

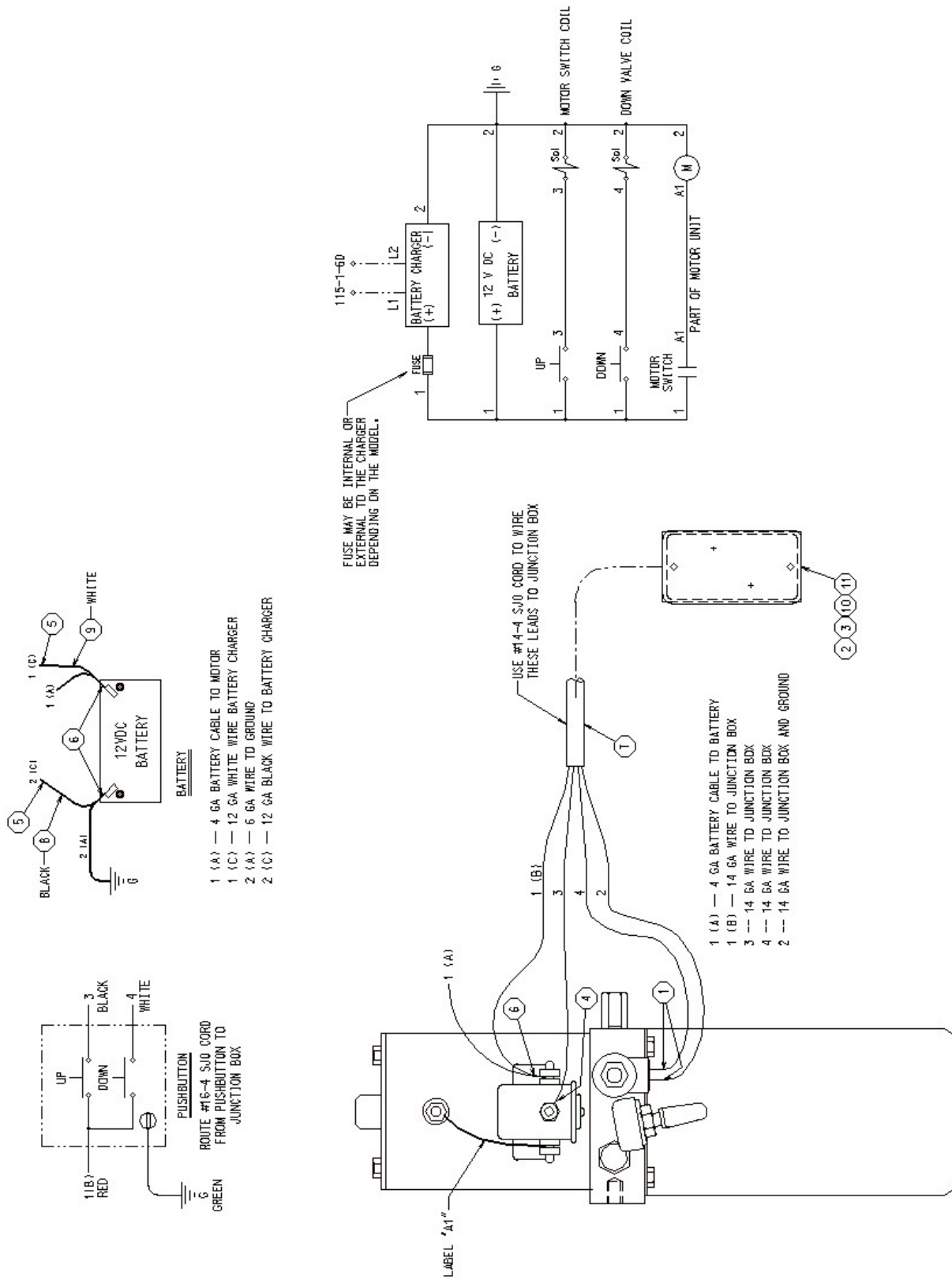

Fig. 14
Battery schematic

2 Year Warranty

Southworth Products Corp warrants this product to be free from defects in material or workmanship for a period of **2 years** of single shift usage from date of shipment, providing claim is made in writing within that time period. This warranty shall not cover modified designs for special applications, failure or defective operation caused by misuse, misapplication, negligence or accident, exceeding recommended capacities, failure to perform required maintenance or altering or repairing, unless alteration is authorized by Southworth Products Corp. Except as set forth herein, there are no other warranties, express or implied, including the warranties of merchantability and fitness for a particular purpose, all of which are hereby excluded.

All **batteries have a 90 day parts and labor** warranty, this warranty covers any defects in material and workmanship from the date of shipment.

Southworth Products Corp makes no warranty or representation with respect to the compliance of any product with state or local safety or product standard codes, and any failure to comply with such codes shall not be considered a defect of material or workmanship under this warranty. Southworth Products Corp shall not be liable for any direct or consequential damages arising out of such noncompliance.

Southworth Products Corp's obligation under this warranty is limited to the replacement or repair of defective components at its factory or another location at Southworth Products Corp's discretion. The Southworth Warranty is for product sold with in North America. For products shipped outside of North America the warranty will be for replacement of defective parts only. Labor is not included. This is buyer's sole remedy. Except as stated herein, Southworth Products Corp will not be liable for any loss, injury or damage to persons or property, nor for direct, indirect, or consequential damage of any kind, resulting from failure or defective operation of said product.

This warranty may be altered only in writing by Southworth Products Corp, Portland, Maine.

SOUTHWORTH

SOUTHWORTH PRODUCTS CORP
P.O. Box 1380, Portland, ME 04104-1380
Telephone: 800-743-1000 • 207-878-0700
Fax: 207-797-4734

SOUTHWORTH

making work faster, safer, and easier

Southworth is the world class supplier of products designed to improve productivity and enhance safety. Our staff has over 400 years of engineering experience. If one of our standard products does not meet your needs, our engineers can custom design equipment specifically suited to your material handling application.



Spring PalletPal Load Leveler



Lift with Flush Mount Turntable



Portable Container Tilters



Dock Lifts



Roll on Level Loaders



Portable Lifts



Stack-n-Go Powered Stacker



**Floor Height Lifts
Roll-E**

**Floor to
Mezzanine Lifts**



Pallet Rotators



For more information, contact Southworth Products

Telephone (800) 743-1000 Fax (207) 797-4734

Email: salesinfo@SouthworthProducts.com