

OWNER'S MANUAL

SOUTHWORTH

Backsaver Lite Lifts



Model # _____

Serial # _____

SOUTHWORTH PRODUCTS CORP

P.O. Box 1380 • Portland, ME 04104-1380

Telephone: (207) 878-0700 or (800) 743-1000

Fax: (207) 797-4734

www.SouthworthProducts.com

Email: service@SouthworthProducts.com

Revised February 2011

Please note: This manual was current at the time of printing.
To obtain the latest, most updated version, please contact Southworth's Customer Service Department or go to our website: www.SouthworthProducts.com, under E-Parts & Service you will find a complete list of current owner's manuals to print.

CONTENTS

INTRODUCTION 4
 Safe Servicing of the Lift..... 5
 SAFETY 6
 INSTALLATION INSTRUCTIONS 6
 Preparation 6
 Positioning the Lift 7
 Hydraulic Connections 7
 Electrical Connections 7
 Testing 7
 Completing Installation 8
 Preparing to Charge a Battery..... 9
 Battery Charger Connections & Precautions..... 9
 OPERATING INSTRUCTIONS 10
 Operating Procedure 10
 MAINTENANCE 13
 Hazards 13
 Routine Periodic Maintenance 13
 TROUBLESHOOTING 15
 Repacking Cylinders..... 17
 Replacing Leg Rollers 18
 ORDERING REPLACEMENT PARTS..... 27
 2 YEAR WARRANTY 28

List of Figures & Tables

Figure 1 Safe Servicing of Lift 5
 Figure 2 Mount the Lift Securely (Backsaver Lite & BSL Compact) 6
 Figure 3 Center the Load 10
 Figure 4 Secure the Load 10
 Figure 5 Pinch Points - Backsaver Lite Compact 11
 Figure 6 Pinch Points - Backsaver Lite & Backsaver Lite Portable 11
 Figure 7 Labels and Precautionary Markings 12
 Figure 8 H-Style Cylinder 18
 Figure 9 Parts Identification, Backsaver Lite 19
 Figure 10 Parts Identification, Backsaver Lite 20
 Figure 11 Parts Identification, Backsaver Lite Portable 21
 Figure 12 Parts Identification, Backsaver Lite Portable 22
 Figure 13 Parts Identification, Backsaver Lite Compact 23
 Figure 14 Hydraulic Diagram - Unit Powered by Electric Motor 24
 Figure 15 Hydraulic Pump and Down Valve 24
 Figure 16 Parts Identification, Backsaver Lite 25
 Figure 17 Parts Identification, Backsaver Lite 25
 Figure 18 Electrical Connections, Lifts Wired for Single-Phase AC 26
 Figure 19 Hydraulic Connections 26

 Table 1 Hydraulic Oil Specifications 27

INTRODUCTION

The Backsaver Lite Lift series includes three basic configurations. Stationary, Portable (with a DC power unit) and Compacts with extended vertical travel in a small footprint. The Backsaver Lite Lift is a stationary lift with a capacity that ranges from 550 lbs up to 1,500 lbs with a variety of table top sizes. The Backsaver Lite Lift compact is also a stationary lift with a capacity that ranges from 500 lbs to 1,000 lbs. It has a vertical travel of up to 30" with only a 12" x 24" footprint. The Backsaver Lite Lift portable rolls easily on four 5" casters with a capacity that ranges from 550 lbs to 1,100 lbs. The portable unit has an internal DC power unit with its own built in charger.

This manual contains information to acquaint you with the safe and proper installation, use, and maintenance of the Backsaver Lite Lift. You should ensure that this manual is available to personnel working with the Backsaver Lite Lift and require its use by these personnel. Backsaver Lite Lift tables are designed for lifting and vertical positioning of equipment and materials in a wide variety of industrial settings. The instructions set forth in this manual are not necessarily all-inclusive, as Southworth cannot anticipate all conceivable or unique situations. In the interest of safety, please read this entire manual carefully, and be familiar with its contents before you install, use, or service the Backsaver Lite Lift table. If you have any questions about any instructions in this manual, please contact your dealer or Southworth Products Corp. Southworth's product warranty is shown on the back cover of this manual.

This instruction manual is not intended to be or to create any other warranty, expressed or implied, including any implied warranty of merchantability or fitness for a particular purpose, all of which are hereby expressly excluded. As set forth more specifically in the product warranty. Southworth obligation under that warranty is limited to the repair or replacement of defective components, which shall be the buyer's sole remedy. Southworth shall not be liable for any loss, injury, or damage to persons or property, nor for any direct, indirect, or consequential damage of any kind resulting from the lift table.

SAFE SERVICING OF THE LIFT

This is the only safe way to work under a lift table. In this manual, we will refer you to this procedure many times. **In the interest of safety, please follow all of these steps whenever you work under the lift table:**

1. **Remove the payload** from the table top.
2. **Raise the lift table** to the full up position. Do not let the table stop part way up.
3. **Move both maintenance devices** into position as shown in Fig. 1. Lower the table just a bit so the movable legs are resting against the maintenance devices. This will release the pressure in the hydraulic system. If you do not do this, pressure may remain in the hydraulic system. If this pressure is released suddenly, you may be hurt, or the lift may be damaged. Once in position the maintenance devices will keep the legs from moving, and prevent the lift from dropping suddenly.



WARNING !

Be sure to use both the left and right maintenance devices. Both the left and right maintenance devices supplied with your machine must be used to support the table safely.

4. **Complete the work** under the lift table, then reverse the process to get the lift ready for operation.
5. **Repeat this procedure** everytime you must work under the lift table. Do this even if you will only be under the table for a moment!

Rotate both maintenance devices into position.

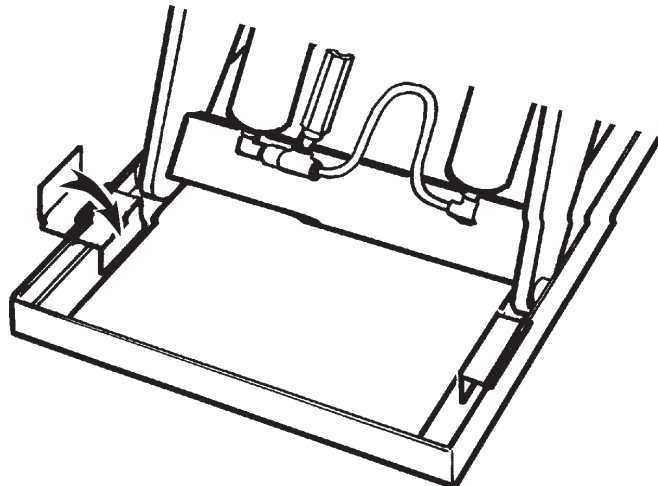

Figure 1 – Safe Servicing of Lift

SAFETY

The safety of all persons operating, maintaining, repairing, or in the vicinity of the Backsaver Lite Lift is of paramount concern to Southworth. The Backsaver Lite Lift is a powerful machine with moving parts, and is **capable of causing personal injury if proper precautions are not taken**.

Therefore, throughout this manual, Southworth has identified certain hazards which may occur in the use of the Backsaver Lite Lift, and provided appropriate **instructions** or **precautions** which should be taken to avoid these hazards. In some cases, Southworth has also pointed out the **consequences** that may occur if Southworth's instructions or precautions are not followed. Southworth uses the following system of identifying the severity of the hazards associated with its products:

SIGNAL WORD

The word or words that designate a degree or level of hazard seriousness. The signal words for product safety signs are **“DANGER, WARNING and CAUTION”**.

- “DANGER”** Immediate hazard which will result in severe personal injury or death.
- “WARNING”** Hazardous or unsafe practice which could result in severe personal injury or death
- “CAUTION”** Hazardous or unsafe practice which could result in minor personal injury or property damage. Please read and follow the instructions in this manual, including all safety instructions and precautions, carefully and completely.

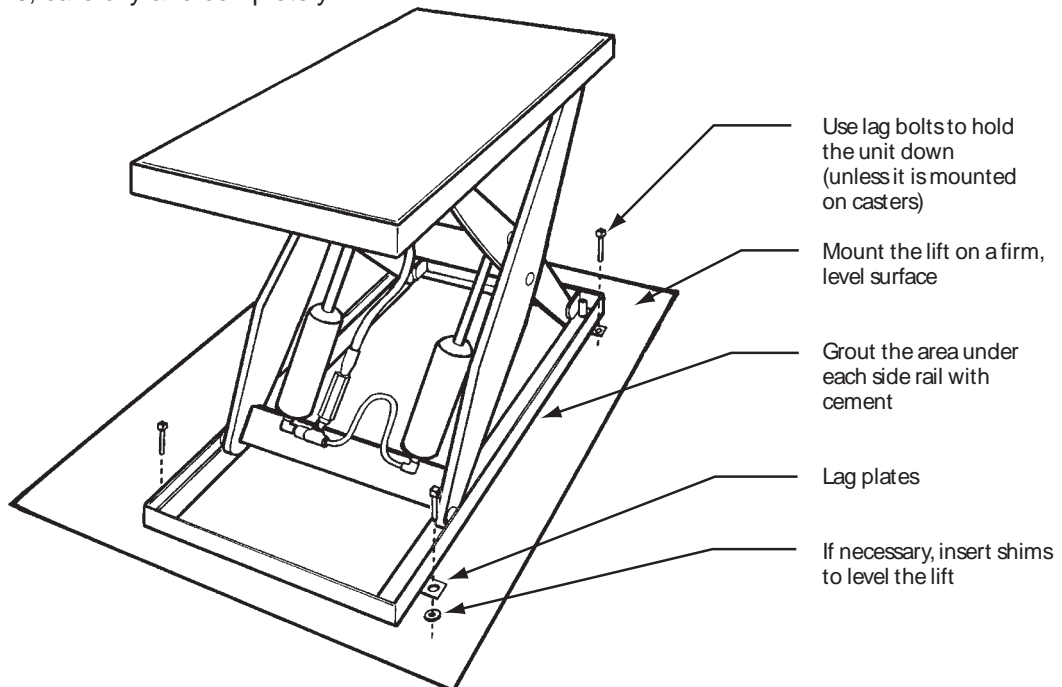

Figure 2 – Mount the Lift Securely (Backsaver Lite and Backsaver Lite Compact)

INSTALLATION INSTRUCTIONS

Backsaver Lite Lift and Backsaver Lite Compact

Section does apply to the Backsaver Lite Portable

Preparation

Before you start to install the lift, check for local codes and ordinances which may apply. It is your responsibility to obtain any necessary permits. Read all of these

installation instructions carefully. Be sure to read and understand all of the warnings! If the power unit will be mounted away from the lift (“external power unit”), check the mounting arrangement for the power unit. The power unit should be sheltered from the weather. It should be mounted within 20 feet of the lift to minimize the pressure drop in the hydraulic system. Be sure the hydraulic lines have been installed properly.

WARNING!

Protect the power unit from rain or moisture. If the electrical parts in the power unit get

wet, workers may be hurt by electrical shock. The electrical parts may fail if they are wet.

WARNING!

The electric motor in the lift can create sparks. Do not install the power unit in an area where flammable gases may be present.

If the power unit is mounted within the lift ("internal power unit"), you will need these tools:

- A crane or lift truck that can lift the unit safely.
- Shims and lag bolts.
- A drill and bit to drill the holes for the lag bolts.
- A power supply with the specified voltage, including fuses or circuit breakers as specified in Figures 16 through 18.

If the power unit will be mounted away from the lift ("external power unit"), you will also need:

- A compressed air source for clearing the hydraulic lines.
- Extra hydraulic oil for flushing the underground lines and refilling the tank. See Table 1 for the oil specifications.

Positioning the Lift

Remove the shipping material and unskid the lift. On the front of this manual, write down the model number, serial number, and date the lift is placed in service. You can find the model number and serial number on the name plate as shown in Figure 10. You cannot see the name plate without lifting the table top. Use an overhead crane or fork truck to do this. Lift the hinged end of the table top. Move the lift into position, supporting the base of the lift. Install the lift as shown in Figure 2.

CAUTION!

Do not hang the lift from the table top. This can damage the lift.

WARNING!

If the lift is mounted on an unstable surface, it may tip over when it is in use. You may be hurt, and the lift and load may be damaged.

Hydraulic Connections

Install the power unit. Install the hydraulic line between the power unit and the lift. Blow out the hydraulic line with compressed air before connecting it to the power unit. Replace the solid plug on the hydraulic fluid tank with the vented plug supplied, then attach the vent line from the cylinder(s) to the vented plug.

WARNING!

Be sure that the hydraulic line will not be pinched by the lift as it raises or lowers. If you allow the line to be pinched, the lift may not work properly. A hose may break, the lift table may drop suddenly, and someone may be hurt.

NOTICE!

It is very important to keep the hydraulic oil free of dirt, dust, metal chips, water, and other contamination. Most of the problems with hydraulic systems are caused by contamination in the oil. Be sure to flush all hydraulic lines before connecting remote power units.

CAUTION!

If you do not install the vented plug in the tank, the pump may be damaged.

Electrical Connections

DANGER!

The lift may use a power supply of up to 115 Volts AC. This voltage can kill you. Do not work with the electrical parts unless you are a qualified electrician.

Make temporary electrical connections to the lift, as shown in Figure 17 or 18. This temporary set-up will allow you to raise the lift.

WARNING!

A 20 amp breaker is required.

CAUTION!

If you have a unit designed for three-phase AC and you connect the power so the motor runs backwards, the lift will not operate, and you may damage the pump. Do not operate the lift for more than 2 or 3 seconds if you think the motor might be turning backwards. **NOTE: Make sure the maintenance devices are not in the roller path.**

Raise the lift and insert the maintenance devices, as shown in Figure 1. Make the permanent electrical connections as shown in Figure 17 or 18. Check the level of the hydraulic fluid. On most models, when the lift is fully elevated, the oil should be about 3/4 inch above the bottom of the tank. Use a dipstick to check the oil level, and add oil as necessary.

Testing (applies to all lifts)

Clear the area around the lift. Remove any loose wires, lumber, or other materials that might get in the way of the lift as it raises or lowers. Make sure

Backsaver Lite Lift

the maintenance devices are not in the roller path. Remove the maintenance devices and warn others to stay away from the lift. Operate the lift through its full range of travel. The lift should rise smoothly with a quiet humming sound, and lower smoothly and quietly. Raise and lower the lift a few times to check the clearances around the lift table.

WARNING!

As the lift table moves up and down, “pinch points” are created at the places shown in Figure 5 or Figure 6. If you are standing too close to the lift when it is moving, your arm or leg may be caught in the moving parts, and you may be hurt. Stay away from the pinch points when the lift is moving.

Completing Installation

Once you are sure the lift is positioned correctly, mark the locations of the lag holes in the base frame, and drill the holes. If necessary, insert metal shims to level the base of the lift. Insert and tighten the lag bolts to secure the lift. Grout under the base rails to prevent vibration and distortion of the base frame, as shown in Figure 2. If the lift is lowering too quickly or too slowly, you can change the “down speed” by adjusting the flow control.

WARNING!

When adjusting the flow control, always raise the lift table and insert the maintenance devices, as shown in Figure 1. Do not try to adjust the flow control while pressing the “down” button. If you try this, the lift table may drop suddenly, and you may be hurt.

It is important that you follow these steps when adjusting the flow control:

- Raise the lift table and insert the maintenance devices, as shown in Figure 1.
- If you want the lift to lower more slowly, turn the control clockwise up to 1/4 turn at a time. If you want the lift to lower more quickly, turn the control counterclockwise up to 1/4 turn. Do not move the control more than 1/4 turn at a time.
- Remove the maintenance devices, and check the descent speed.
- Every time you want to change the adjustment again, raise the table again and insert the maintenance devices as shown in Figure 1.

Test the lift with the rated load. If the lift does not rise, and you hear a loud squealing noise, the pressure relief valve is operating. Contact Southworth for instructions.

WARNING!

Do not continue to use the lift if this happens – the pump will overheat very quickly, and may be permanently damaged. Do not try to adjust the relief valve. If you change the setting on the relief valve, you may overwork the lift. This can cause the lift to fail suddenly, and you may be hurt.

PRECAUTIONS FOR GROUNDING AN AC POWER CORD CONNECTION

Charger should be grounded to reduce the risk of electrical shock. Charger is equipped with an electrical cord having an equipment-grounding conductor and grounding plug. The plug must be plugged into an outlet that is properly installed and grounded in accordance with all local codes and ordinances.

DANGER!

Never alter the AC cord or plug provided. If it will not fit outlet, have proper outlet installed by a qualified electrician. Improper connection can result in a risk of electric shock.

Backsaver Lite Portable

DC POWER UNIT WITH CHARGER

This power unit comes equipped with a 1/2 hp 12 Volt DC motor, pump with an attached 3/4 liter or a quart capacity tank, transformer with an in-line resetting fuse and a 12 Volt DC battery. When charging the battery it is important to remember that the lift should not be operated. Also the lift should be elevated resting on the maintenance devices for ventilation purposes. The battery charging procedure will take an estimated 5.5 hours to complete. The charger is equipped with an automatic shut off switch which enables the unit to be charged whenever it is not in service. With the battery fully charged, the 1100 lb unit will do approximately 60 cycles under a full load and 240 cycles under an empty load. The 550 lb unit will do approximately 120 cycles under a full load and 480 cycles under an empty load.

LOCATING THE CHARGER

Locate the charger as far away from the battery as the cables permit above floor level.

Do not operate the charger in a closed area or restrict ventilation in any way.

Preparing to Charge a Battery

1. Be sure area around lift and the battery is well ventilated while battery is being charged.
2. The battery terminals, connections and wiring including the plug in the battery box and charger connections should be clean and free of corrosion. When cleaning any of these components wear a face shield or suitable protective eyewear.
3. For a sealed battery (a battery without sell caps) carefully follow the manufacturer's recharging instructions which are provided with the battery. If you do not have a copy of these instructions or the instructions for the battery charger, they are available free of charge by calling Southworth Products Corp at 800-743-1000.
4. Read, understand and follow all battery and battery charger manufacturer's specific precautions while working with and/or charging batteries.

PRECAUTIONS FOR GROUNDING AND AC POWER CORD CONNECTIONS

Charger should be grounded to reduce the risk of electric shock. Charger is equipped with an electrical cord having an equipment-grounding conductor and grounding plug. The plug must be plugged into an outlet that is properly installed and grounded in accordance with all local codes and ordinances.

DANGER!

Never alter the AC cord or plug provided. If it will not fit outlet, have proper outlet installed by a qualified electrician. Improper connection can result in a risk of electric shock.

BATTERY CHARGER CONNECTION PRECAUTIONS

Connect and disconnect the DC output plug (or clips) only when the AC cord is disconnected from the electric outlet. Never allow clips to touch each other.

When hooking up the charger, attach the plug into the twist-lock receptacle on the side of the battery box or connect the clips directly to the battery on units that are not pre-wired with a plug on the side of the battery box.

For unit not equipped with a twist-lock, pre-wired charger plug, follow these additional precautions.

Check polarity of battery posts. POSITIVE (POS, P, +) battery post usually has larger diameter than NEGATIVE (NEG, N, -) battery post. Determine which post of battery is grounded (connected) to the chassis of the machine. Connect the NEGATIVE (black) clip from the battery charger to the machine chassis as far away from the battery as possible. The POSITIVE (red or white) clip from the battery charger to the POSITIVE (POS, P, +) post of the battery. When making each connection, twist or rock clip back and forth several times to make a good

connection and to reduce the risk of a clip slipping off and creating a spark. Do not twist or rock clip on the battery after the second clip connection is made. When disconnecting the charger, disconnect AC cord from the electrical outlet before removing and clips from battery or chassis.

IF THESE INSTRUCTIONS ARE NOT CLEAR OR IF YOU NEED ADDITIONAL INSTRUCTIONS OR IF THERE ARE ANY QUESTIONS, PLEASE CONTACT SOUTHWORTH PRODUCTS CORP.

Phone: 800-743-1000

Fax: 207-797-4734

E-mail: service@SouthworthProducts.com

Backsaver Lite Lift

OPERATING INSTRUCTIONS

Operating Procedure

Before operating the lift, read and understand this entire section.

DANGER!

The lift may use a power supply of up to 115 Volts AC. This voltage can kill. Do not work with the electrical parts unless you are a qualified electrician!

Locate the lift on a firm, flat surface as shown in Fig. 2. Stationary lifts should be lagged to the floor. The floor lock should be engaged on portable lifts.

WARNING!

If you place the lift on a soft surface, it may tip over, especially when it is loaded or raised. Someone may be hurt, and the lift and load may be damaged. Load the lift correctly.

Be sure that the load weighs no more than the maximum rated capacity for the lift. The maximum rated capacity is shown on the platform skirt.

WARNING!

Do not try to lift a load that exceeds the maximum rated capacity. If you try this, the lift may fail suddenly. Someone may be hurt, and the lift and load may be damaged.

- Place the load in the center of the lift table, as shown in Fig. 3.
- Do not try to load the lift while the lift table is moving.
- If you are lifting pipes or other objects which may be able to roll or move, fasten them down, or chock them. Fig. 4. Be sure all workers are clear of the lift. Remove any material which may fall onto the lift.

WARNING!

Do not use the unit to lift people. A specially equipped lift will include operator protection, and an excess flow protector to keep the lift from dropping suddenly if a hydraulic line is damaged.

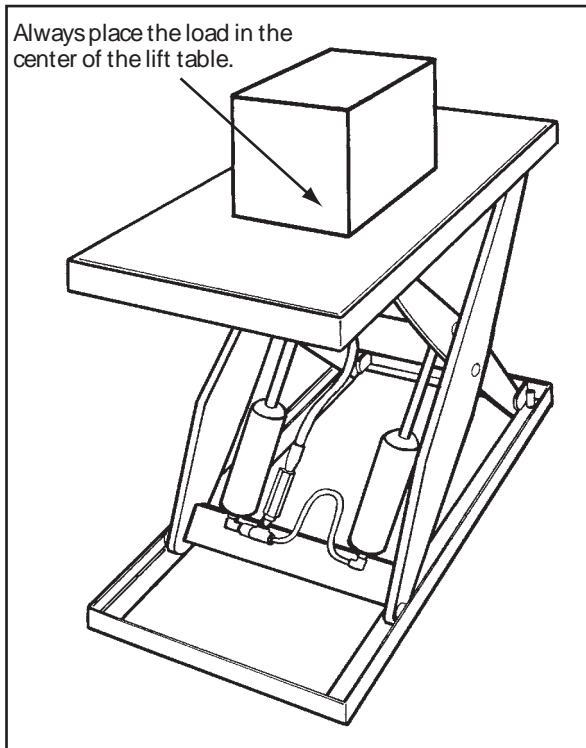

Figure 3 – Center the Load

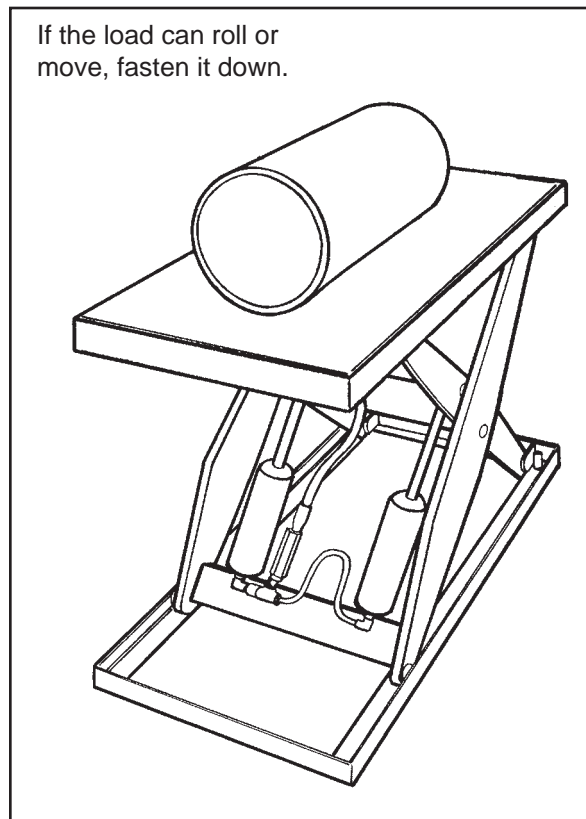

Figure 4 – Secure the Load

WARNING!

As the lift table moves up and down, “pinch points” are created as shown in Figures 5 and 6. Stay away from these pinch points! Part of your body or clothing may become caught, and you may be hurt.

Operate the lift. Press and hold the “up” button to raise the lift, and “down” button to lower it. If the lift does not operate right away, turn off the lift and call a qualified maintenance worker.

WARNING!

If you hear a squealing noise from the pump, the pressure relief valve is operating. Do not continue to use the lift! The pump will overheat very quickly, and may be permanently damaged. The relief valve is included to protect the machine operators – do not change the relief pressure setting.

Wait until the lift table has stopped. Unload the lift.

NOTICE

The precautionary labels on the lift are there for your safety. If you find that the labels are worn or missing, or have been painted over, ask Maintenance to replace the labels before you use the lift. The labels are shown in Fig. 7

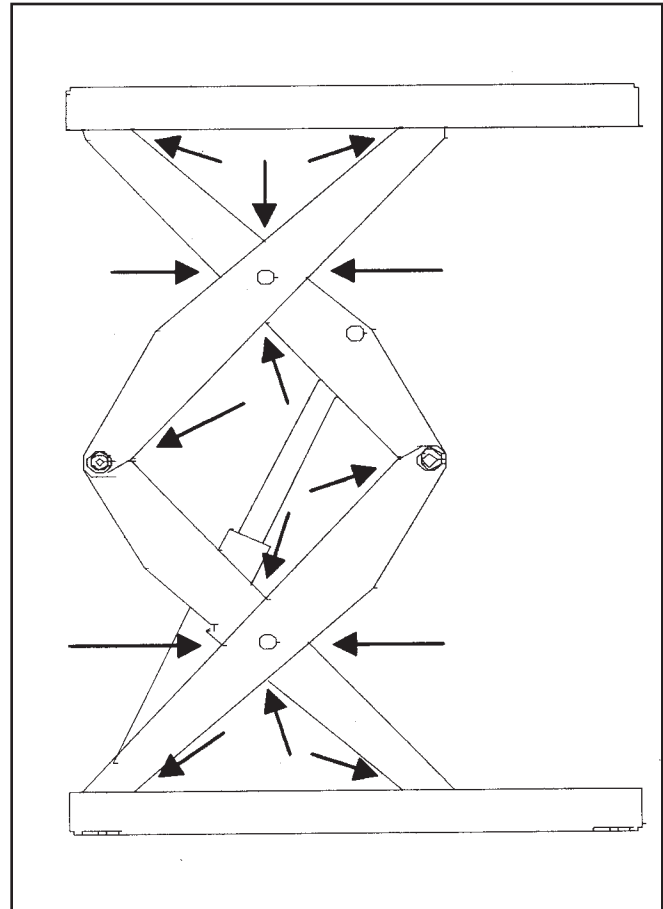

Figure 5 – Pinch Points for Backsaver Lite Compact

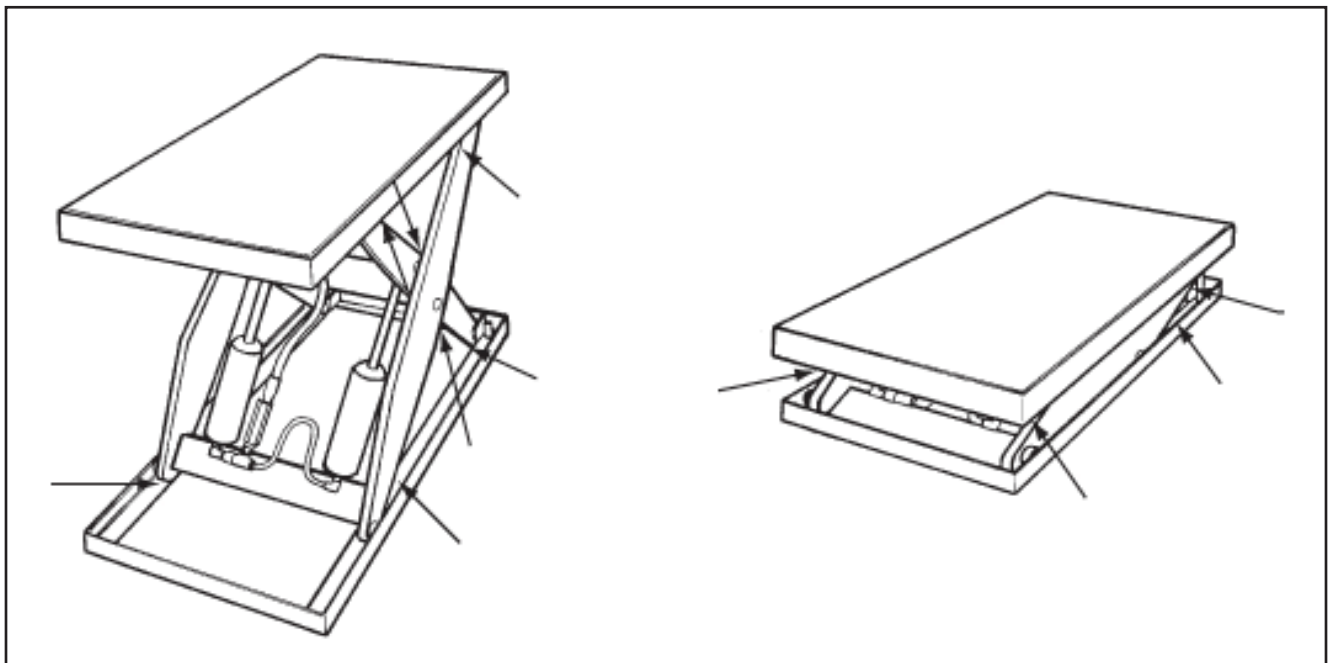

Figure 6 – Pinch Points for Backsaver Lite and Backsaver Lite Portable

Backsaver Lite Lift

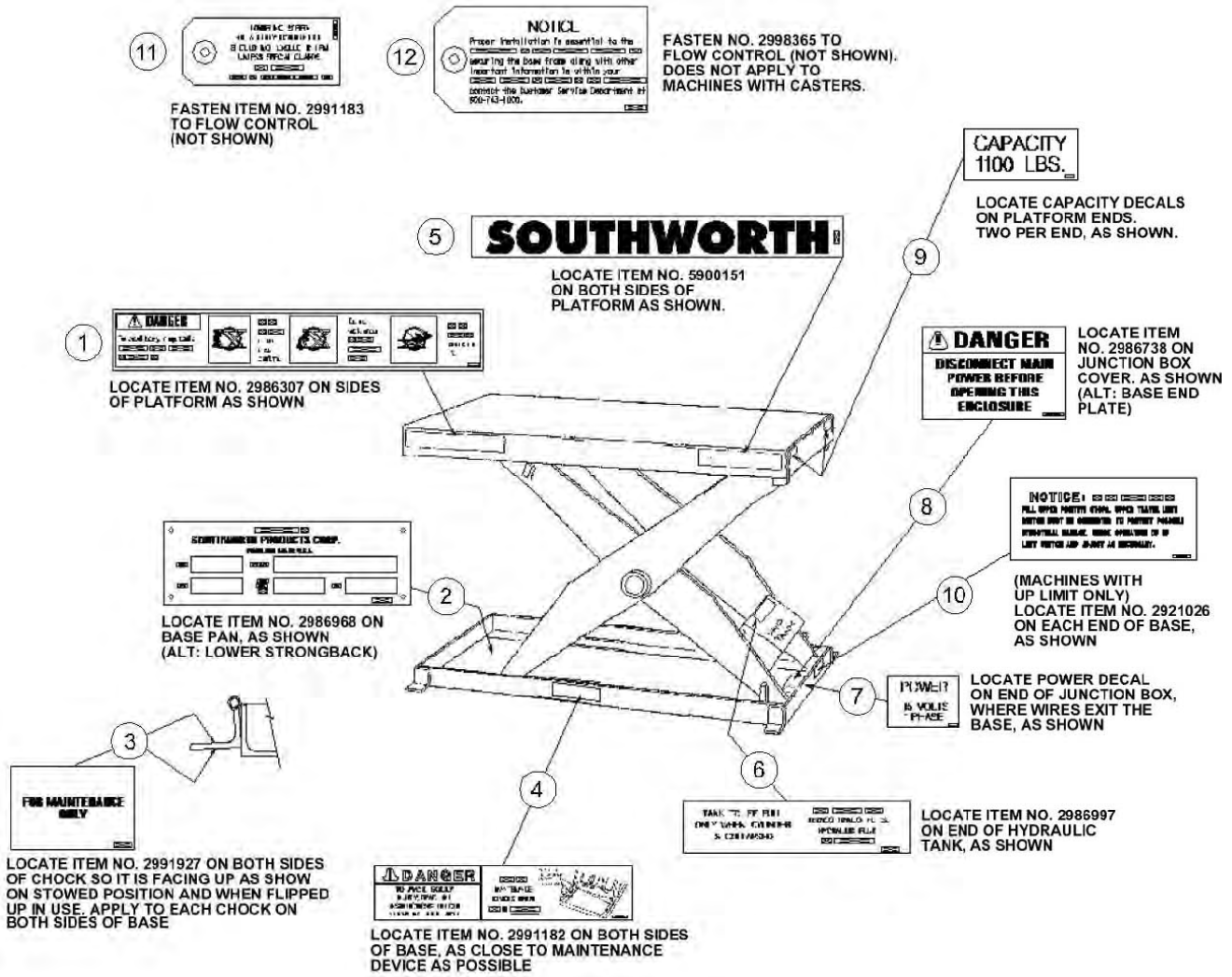

Figure 7 – Labels and Precautionary Markings

Item	Part #	Location	Item	Part #	Location
1	2986307	On both sides of the table top as shown	8	2986738	On junction box cover. (alt: base end plate)
2	2986968	On basepan as shown (alt: Lower Strongback)	9	Capacity Decals: 2998433 (500#) 10002101 (550#) 2998425 (1000#) 10002102 (1100#) 2998434 (1500#) 5900159 (other)	Platform Ends
3	2991927	On both sides of safety chock as shown	10	2921026	On each end of base as shown (machines with up limit only)
4	2991182	On both sides of base as close to maintenance device as possible	11	2991183	Fasten to flow control
5	5900151	On both sides of platform as shown	12	2998365	Fasten to flow control
6	2986997	On end of hydraulic tank as shown			
7	Power Decals: 2987000 (115/1/60) 2991783 (12VDC)	On end of junction box, where wires exit the base as shown			

MAINTENANCE

All servicing should be done by qualified personnel. Qualified personnel should be able to read and understand wiring and hydraulic diagrams. They should be able to troubleshoot live electrical circuits safely and in accordance with accepted practice. **For safety's sake**, if in doubt, please contact your dealer or Southworth's Customer Service Department at (207) 878-0700 or (800) 743-1000. Before servicing the lift, read and understand this entire section and the section entitled "Operating Instructions."

Hazards

There are several hazards you should be aware of as you service the lift:

DANGER!

The lift may use a power supply of up to 575 Volts AC. This voltage can kill. Do not work with the electrical parts unless you are a qualified electrician!

WARNINGS!

- As the lift moves up and down, "pinch points" are formed as shown in Figure 6. Keep hands, feet, and loose clothing away from these pinch points. If your hand or arm or a part of your clothing is caught, you may be hurt.
- A falling lift can cause severe personal injury. Before working under the lift, raise the lift and insert the maintenance devices, as shown in Figure 1. Do this every time you work under the lift!

WARNINGS!

- Do not change the setting on the relief valve. If you do change the setting, this may cause a hydraulic part to fail. The lift may drop suddenly. Someone may be hurt, and the lift and the load may be damaged. The hydraulic parts in the lift are designed to handle a certain amount of pressure. The relief valve is set to relieve this pressure before it becomes too great. The relief valve has been included for the protection of all of the workers who use the lift.
- Release of fluids under high pressure can cause personal injury. Before you open any part of the hydraulic system, be sure to release the hydraulic pressure.
- The warning labels on the lift are there for the safety of the operators. See Figure 7. If the labels are worn or missing, or have been

Painted over, replace them before releasing the lift for operation.

Routine Periodic Maintenance

Every month:

- Visually inspect the leg rollers, center pivot bushings and pins, cylinder clevis pins and bushings, and the leg hinge pins and bushings for signs of wear. Contact Southworth for instructions for repair of the center pivot pins and bushings.

WARNING!

If you are going to repair the center pivot pins and bushings, you must support the lift table in a special way. Each set of leg plates, on both sides of the unit, must be clamped together firmly, using large C-clamps. You cannot use the maintenance devices shown in Figure 1 – with the pivot pins removed, they will not support the table top. If you do not support the lift table correctly, the top may drop suddenly when you remove the pivot pins. Please contact Southworth for instructions.

Apply oil or WD-40 to the parts listed in the last step.

NOTE: Although the bearings are "lifetime lubricated" their performance may be extended by additional periodic lubrication.

CAUTION!

It is important to use hydraulic fluid with the correct grade and properties. See the hydraulic oil specification in this manual, Table 1.

Every six months or 500 hours of operation, whichever comes first:

Raise the lift and insert the maintenance devices, as shown in Figure 1. Check all of the hydraulic fittings and hoses, and repair the connections as necessary. Occasionally the fittings can be worked loose by the vibrations from the power unit.

WARNING!

If a hydraulic fitting becomes loose, or if a hydraulic hose breaks, the hydraulic fluid may escape from the system under pressure. If the lift is raised when this happens, it can drop quickly. Someone may be hurt, or the lift or load may be damaged.

Backsaver Lite Lift

The clear plastic vent line and the cylinder rod(s) should be free of hydraulic fluid. If you find much fluid in either place, the cylinder seals may be leaking. (It is also possible the tank may be overfilled.) See the section on "Repacking Southworth Cylinders."

- Disassemble the down valve as shown in Figure 15. Blow the valve plunger clean with compressed air. Reassemble and reinstall.
- Drain and discard the hydraulic fluid. The suction filter is in the tank, at the point where the suction line runs out to the pump. Unscrew the hydraulic filter.
- Blow the filter clean. Reinstall the filter in the tank and reassemble the hydraulic line.
- Refill the tank with new hydraulic fluid.

CAUTION!

If you continue to use fluid after it has "worn out," the moving parts in the system will wear more quickly.

Be sure all of the warning labels are in position and legible. The labels are shown in Figures 7 and 8. **The warning labels are intended to protect your workers.** If the labels are missing, or if they have been painted over, replace them.

Rotate the shafts by hand in both directions for a few minutes. Reconnect the airline and gradually increase the air pressure and flow until there is no trace of the solvent in the exhaust air. Re-lubricate the motor with a squirt of oil in the chamber.

TROUBLESHOOTING

PROBLEM	POSSIBLE CAUSE	CHECK THIS
Lift will not raise	Weight of load too heavy	Check the actual weight of the load
	Motor not running	Check the main disconnect switch, fuses, and wiring to the motor. A 20 amp, designated braker must be supplied for 110V
	Hydraulic oil level low	When lift is raised as far as possible, oil level should be 3/4" from bottom of tank. When lift is down, 3/4" from top
	Lift has reached its upper limit	Upper limit switch may need to be adjusted
	Motor may be "single phasing"	If motor hums but does not turn, check motor wiring and line fuses.
	Motor voltage too low	Supply voltage should be +/- 10% of the rating at the motor terminals.
	Tank vent plugged	If supplied, remove solid plug from tank, insert vent plug.
	Suction filter clogged	Clean suction filter as described in periodic maintenance
	Vacuum leak in suction line	Check all fittings in suction line
	Down valve may be energized	Check wiring to down valve, and solenoid in the valve
	Missing coupling	Check to insure the coupling has been installed between the pump and motor
The lift fails to hold	Down valve may be leaking	Remove down valve and inspect for debris which may be preventing it from closing.
	Down valve may be energized	Check the solenoid in the valve with a volt meter.
	Cylinder may be leaking	Check for oil in cylinder in the vent line.
Lift will not lower	Down valve may be de-energized	Check the solenoid in the valve with a volt meter
	Flow control needs adjustment	Adjust flow control as needed
Lift raises too slowly	Voltage may be low	Check voltage at motor to ensure proper voltage is being supplied
	Foreign material clogging suction filter, breather cap or pressure line	Remove necessary components and clean
	Pump may be overheating due to insufficient oil	Check oil level and oil viscosity
Lift lowers too slowly	Down valve may not be fully open or stuck closed	Remove down valve and clean
	Flow control may need adjustment	Adjust flow control as needed

If the steps listed above do not solve the problem, please call the Southworth's Customer Service Department

TROUBLESHOOTING WARNINGS

All servicing should be done by qualified personnel. Qualified personnel should be able to read and understand wiring and hydraulic diagrams. They should be able to troubleshoot live electrical circuits safely and in accordance with accepted practice. **For safety's sake**, if in doubt, please contact your dealer or Southworth Products Corp. Before servicing the lift, **read and understand this entire section and the section entitled "Operating Instructions."**

WARNING!

Before working underneath the lift, always raise the lift and insert the maintenance devices, as shown in Figure 1. Failure to do so may result in damage to the lift and severe personal injury!

If the lift will not raise:

CAUTION !

Do not continue to hold the "up" button for more than 2 or 3 seconds. You may damage the pump.

WARNING!

Do not change the relief valve setting. This valve has been included for the protection of workers who install, use, or service the lift. If it is ever necessary to repair or reset the valve, contact Southworth Products Corp. for instructions.

WARNING!

Do not disconnect the up limitswitch. Instead, loosen the adjusting screw, and change the position of the arm. If you do disconnect the switch, when the lift platform moves up, it may not stop at the correct point. If the platform rises above the normal stopping point, the frame of the unit may be damaged. People working nearby may be hurt.

CAUTION!

If cavitation is allowed to continue, the pump may be damaged, and may have to be replaced.

If the lift elevates, but fails to hold a load:

WARNING!

Failure to insert the maintenance devices may result in damage to the lift and severe personal injury!

If the lift fails to lower:

WARNING!

Failure to insert the maintenance devices may result in damage to the lift and severe personal injury!

DANGER!

Do not try to adjust the flow control while pressing the "down" button. If you try this, the lift table may drop suddenly, and you may be hurt.

Repacking Cylinders

This section will tell you how to repack an "H-style" cylinder, shown in Figure 9. This type of cylinder is exclusive to Southworth, and repacking kits are only available through Southworth. To order a repacking kit, please call the Parts Department at (207) 878- 0700 or (800) 743-1000. When ordering, specify the model number and serial number of the lift, and the cylinder number(s), as listed on the base of the cylinder(s).

Before beginning this procedure, **read and understand this entire section.**

WARNING!

Before working underneath the lift, always raise the lift and insert the maintenance devices, as shown in Figure 1. Failure to do so may result in damage to the lift and severe personal injury!

1. Before you disassemble the old cylinder, be sure you have these items on hand:
 - A repacking kit. Parts may be damaged when you disassemble the cylinder. You should have replacement parts on hand so you can reassemble the lift and use it immediately.
 - A supply of new hydraulic oil. Contaminated oil may damage the new packing.
 - A container to catch the used oil.
 - A clean place to work. Choose a place which will not be damaged if you spill some oil.
2. Raise the lift and insert both the maintenance devices, as shown in Figure 1.
3. Turn off electrical power by unplugging the machine. This will prevent the lift from moving accidentally while you are working on it.
4. Disconnect the cylinder supply line at the pump, and place the end into a container to collect the used oil.
5. Disconnect the vent line at the cylinder(s).
6. At the top end of the cylinder rod, remove the "keeper," and drive out the clevis pin. Push the rod back into the cylinder to drive the hydraulic fluid out through the hose into the container. You may use air pressure at the vent hole to do this. Disconnect the hydraulic line(s) from the cylinder(s). Lift the cylinder(s) out of the lift. Be careful! The cylinder is heavy!
7. Fig. 8 shows the parts inside a lift cylinder. At the upper end of the cylinder, remove the snap ring. Pull the rod and piston all the way out of the cylinder. This assembly is heavy! Be careful not to drop it as it comes free.
8. Remove the press-fit bushing from the hole at the upper end of the cylinder rod.

9. Look for deformation around the hole at the clevis end of the cylinder rod. If necessary, clean up the rod diameter with a file to allow the rod bearing to slide off without damage.

10. Remove the plastic rod bearing from the cylinder rod. Observe how the wiper ring sits in the rod bearing. Remove the wiper ring and the O-ring from the rod bearing. Do not try to remove the aluminum piston from the cylinder rod, as this will damage the assembly. Remove the poly U-cup and the fiber wear ring from the piston.

11. Check the vent plug, and clean it if it appears dirty.

CAUTION!

While reassembling, it is very important to keep all of the parts free of dirt, dust, metal chips, water, and other contamination. Most of the problems with hydraulic systems are caused by contamination in the oil.

12. Clean the piston surfaces, and install a new fiber wear ring. Install a new poly U-cup seal, with the open part of the seal facing down.

13. Clean all of the surfaces on the rod bearing. Install a new O-ring and wiper. Replace the rod bearing assembly on the rod.

CAUTION!

Be careful not to install the wiper backwards. The lip on the wiper should point upwards, as shown in the detail in Figure 8.

14. Clean the bore of the cylinder tube thoroughly. Inspect the bore of the tube for scratches that run up and down, along the length of the cylinder. If you do see any scratches, hone the inner surface of the cylinder. Be sure to clean the tube thoroughly after you do this.

15. Lubricate the seal and piston with clean grease or oil. Carefully insert the piston and rod back into the cylinder. Be very careful not to pinch or tear the poly U-cup as the piston passes the shoulder inside the cylinder. It is helpful to tip the rod assembly and twist it as you slide it into the cylinder. Once the piston is inside the cylinder, it should slide easily.

CAUTION!

If the poly U-cup is pinched or torn during reassembly, the piston may not maintain pressure as designed.

16. Slide the rod bearing into the cylinder. Install a new snap ring to hold the rod bearing in place. Replace the bushing or install a new one in the top of the cylinder rod.

17. Install the cylinder in the lift. Replace the clevis pin and "keeper." Reconnect all of the hydraulic lines and the vent line.

Backsaver Lite Lift

18. At the start of the packing process, you drained the cylinder(s) into a container. Replace this used oil with an equal amount of fresh oil. Be sure to reinstall the vent plug when you're done.

19. Turn on the electrical power and press the "up" button. The pump will self-prime. After a few seconds, the cylinder should lift the table off the blocks. Remove the maintenance devices. Cycle the lift up and down a few times to remove air pockets. Check for leaks.

20. Raise the lift and check the oil level with a dipstick. The oil should be about 3/4 inch above the bottom of the tank.

21. If you have spilled any oil, clean it up.

DANGER!

Spilled hydraulic oil is slippery, and may present a fire hazard. Always clean up any spilled oil.

Replacing Leg Rollers

Please contact Customer Service at Southworth Products Corp. for instructions for your model and application at (207) 878-0700 or (800) 743-1000.

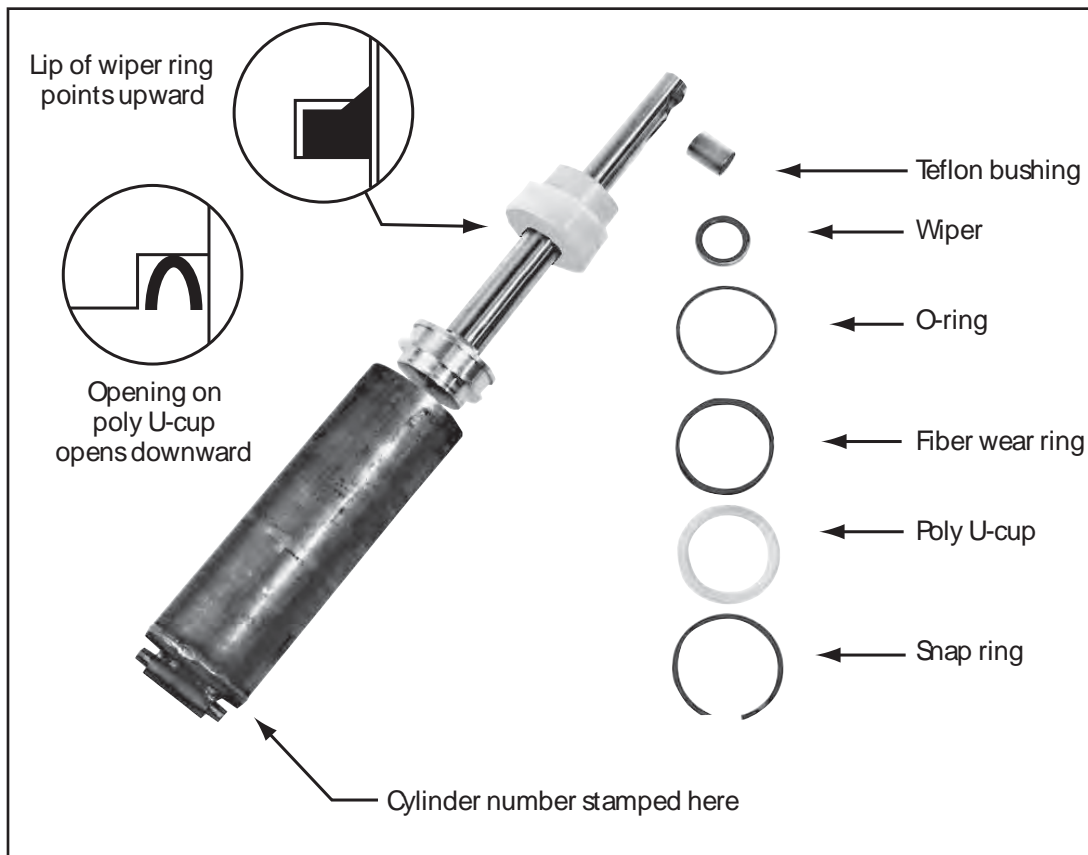

Figure 8 – H-Style Cylinder

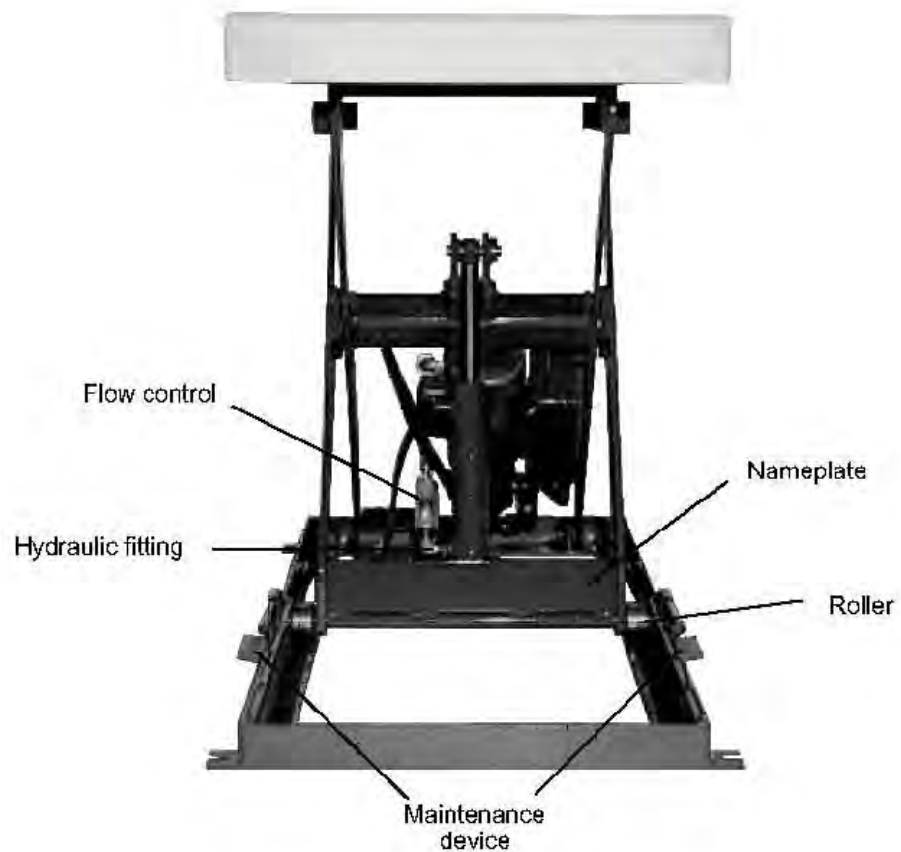
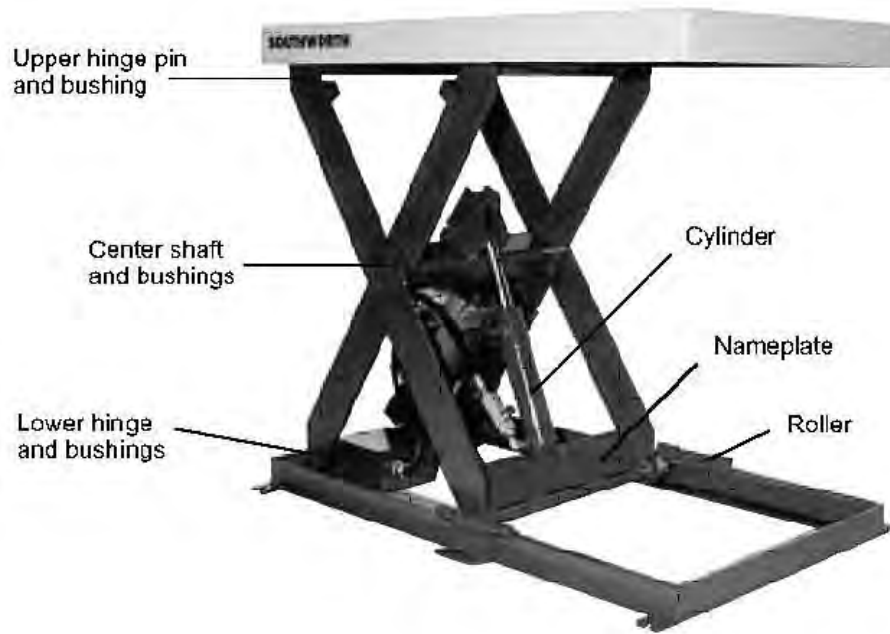

Figure 9 – Parts Identification, Backsaver Lite

Backsaver Lite Lift

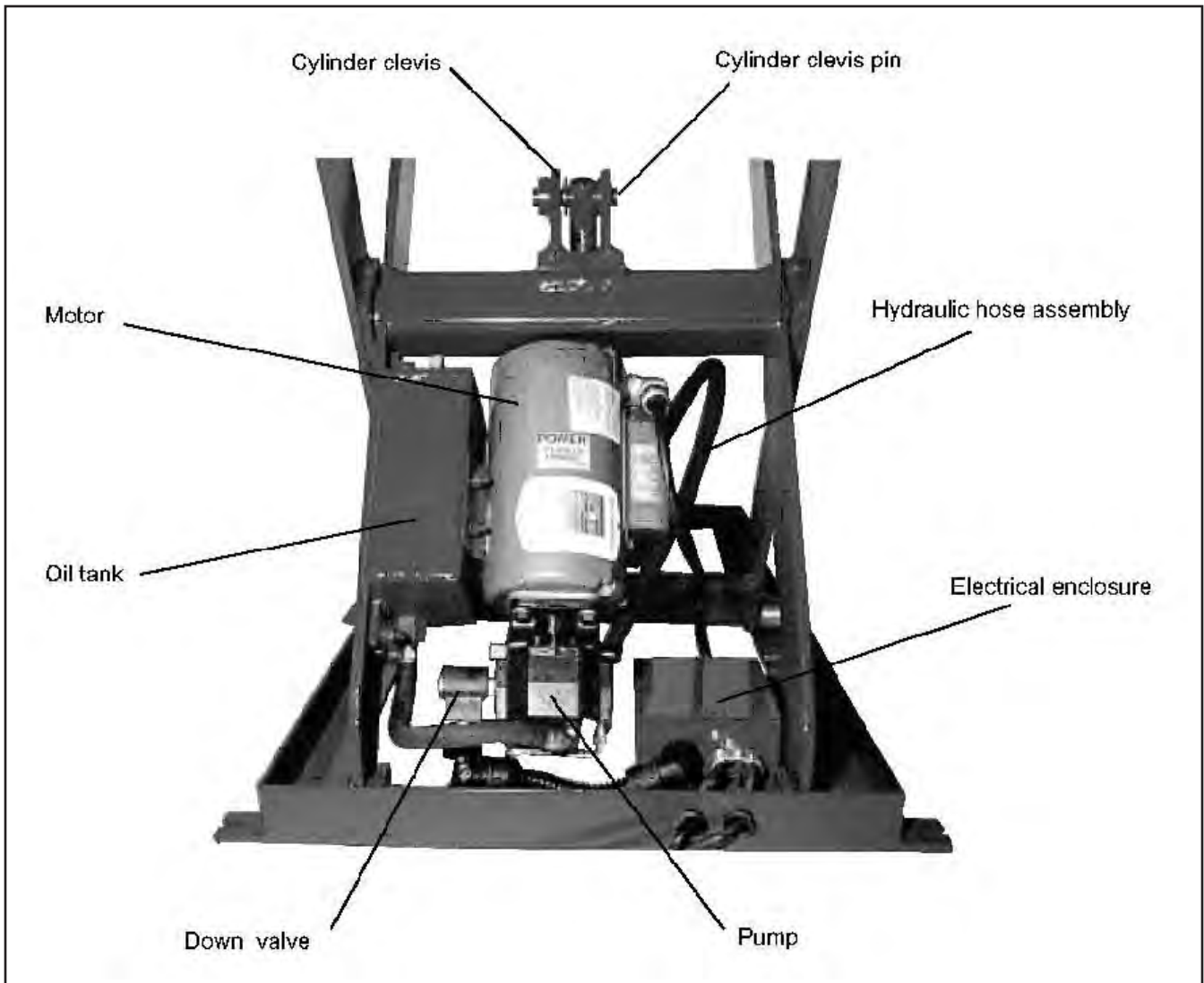

Figure 10 – Parts Identification, Backsaver Lite

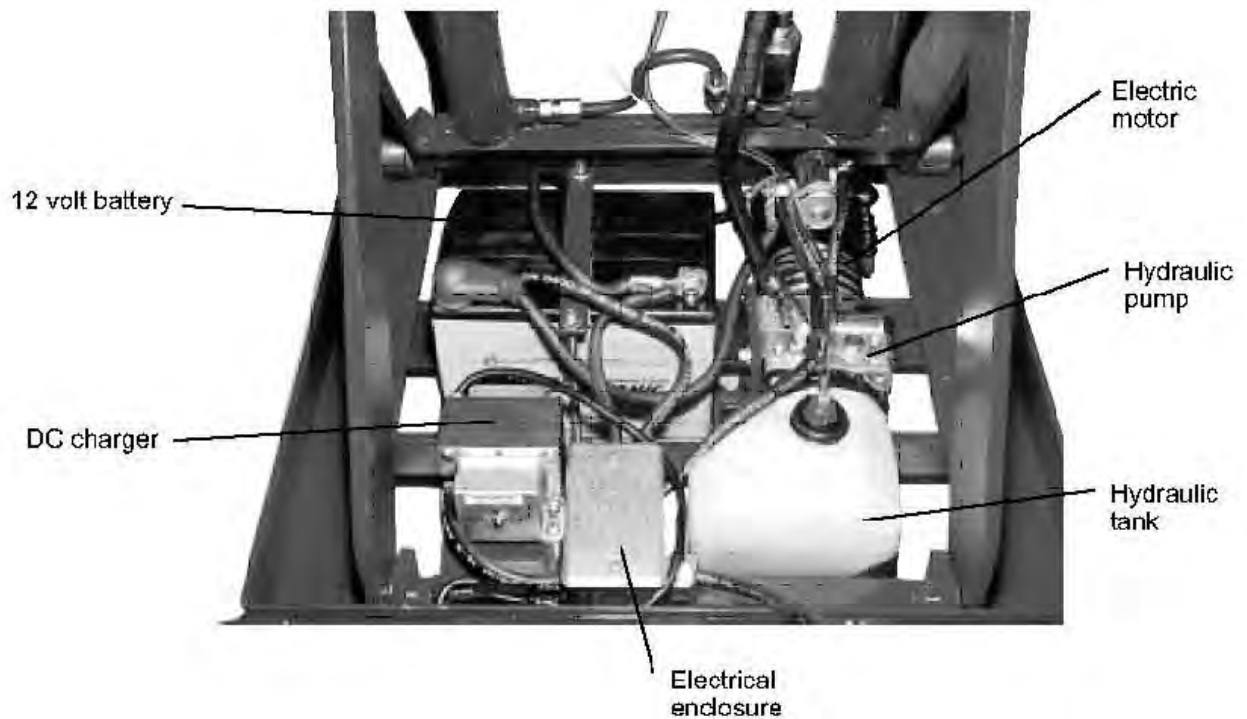
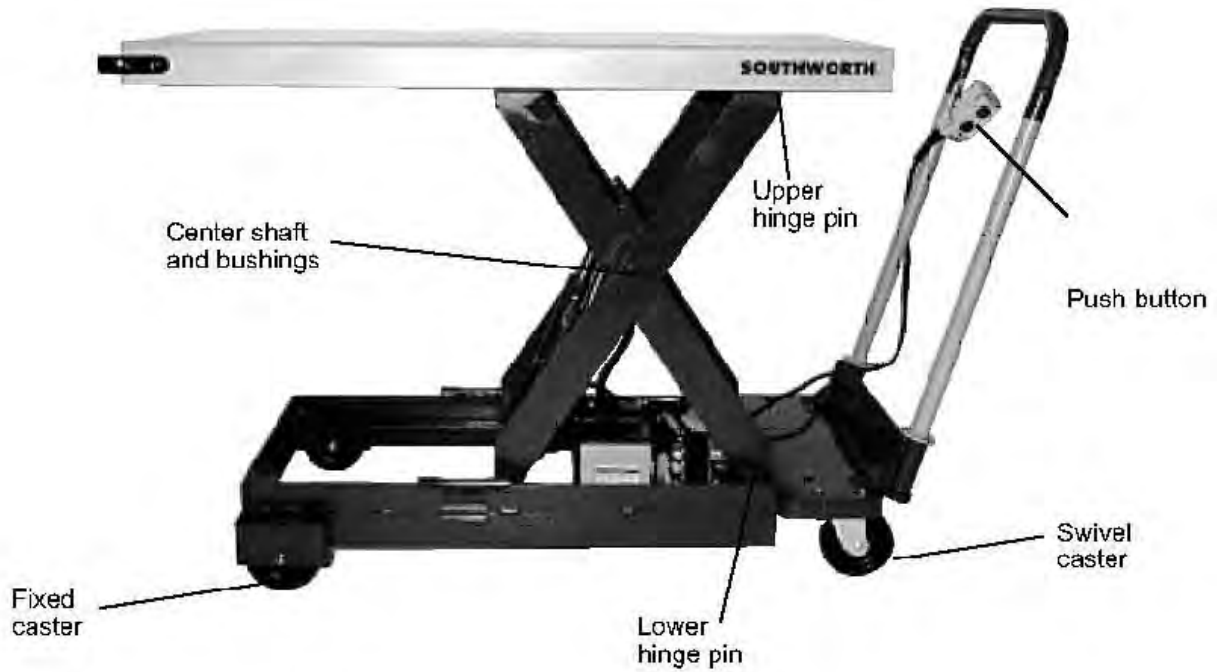

Figure 11 – Parts Identification, Backsaver Lite Portable

Backsaver Lite Lift

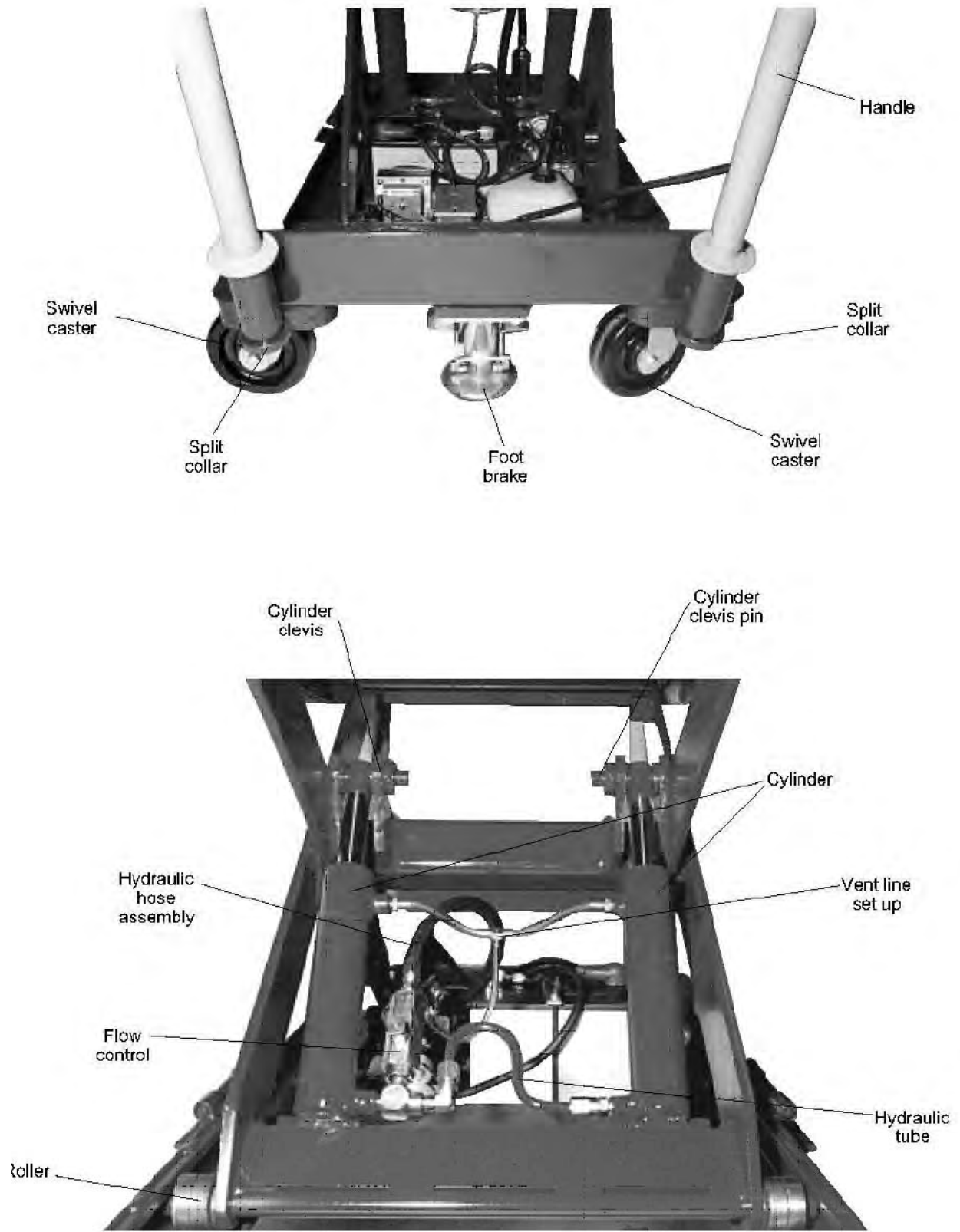

Figure 12 – Parts Identification, Backsaver Lite Portable

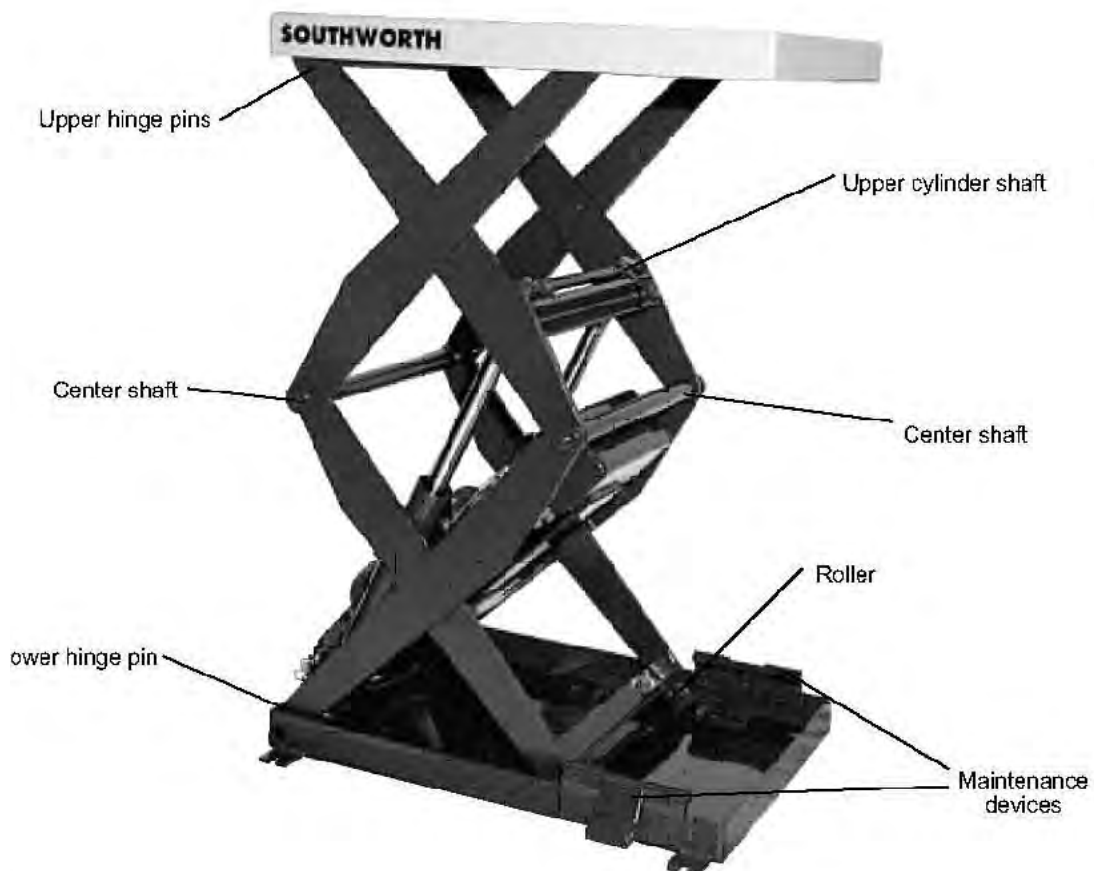
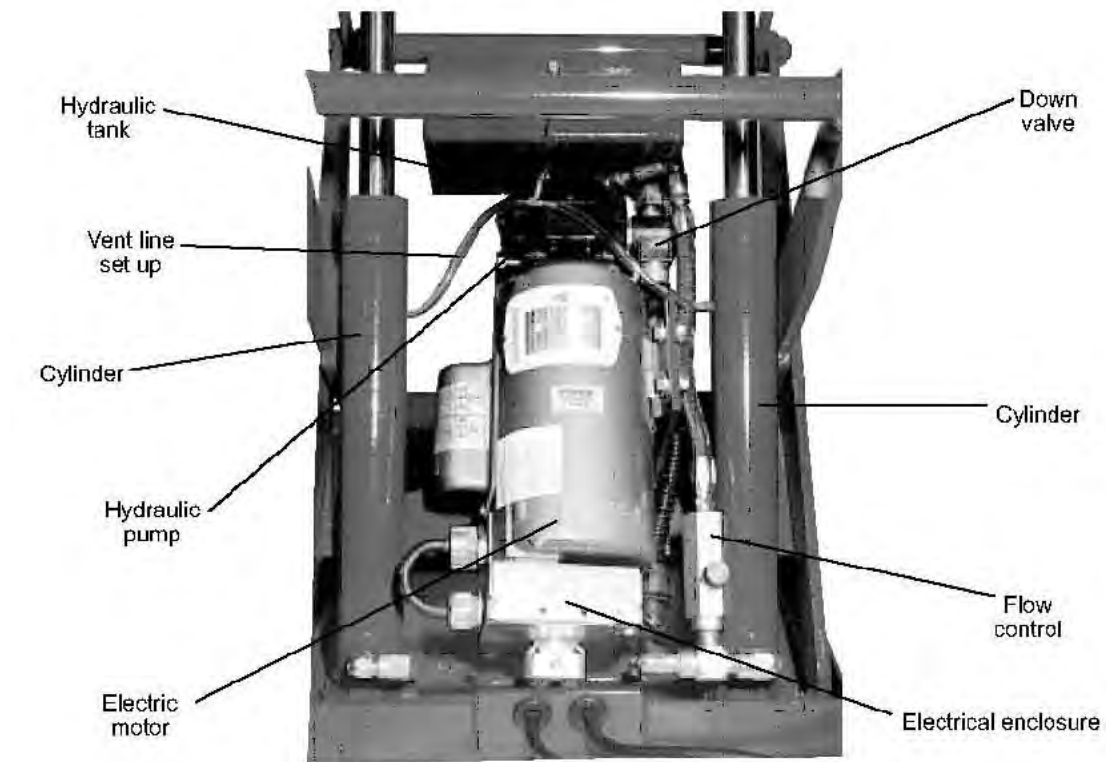

Figure 13 – Parts Identification, Backsaver Lite Compact

Backsaver Lite Lift

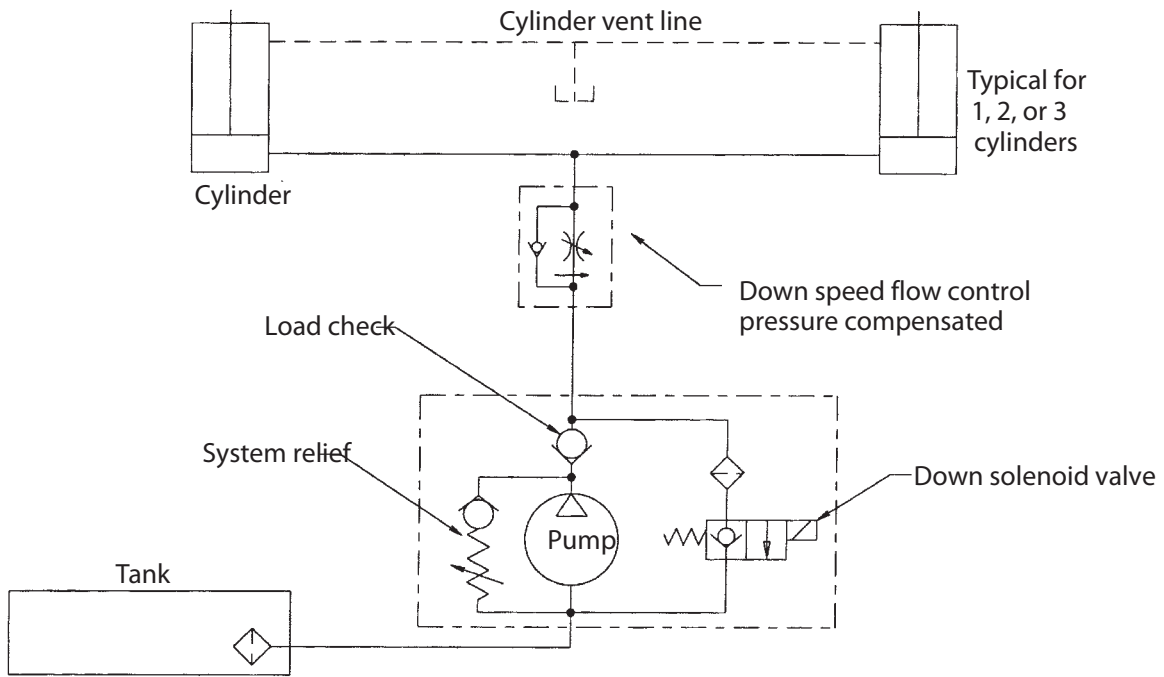

Figure 14 – Hydraulic Diagram - Unit Powered by Electric Motor

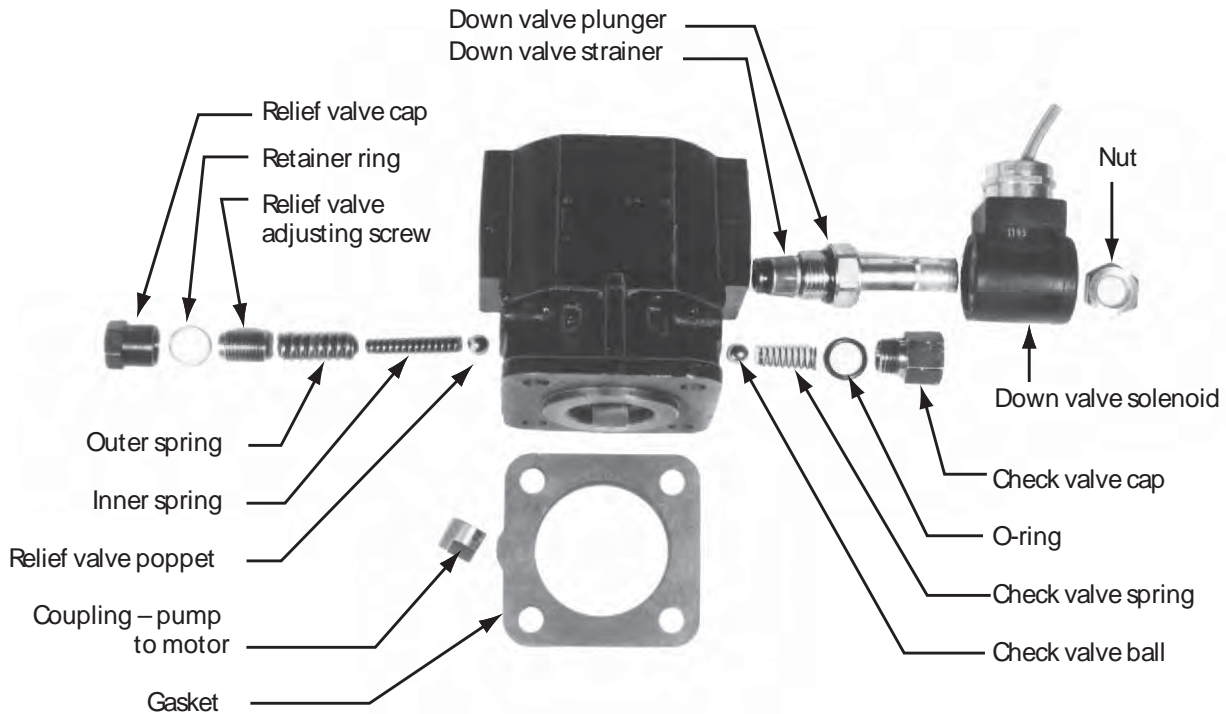
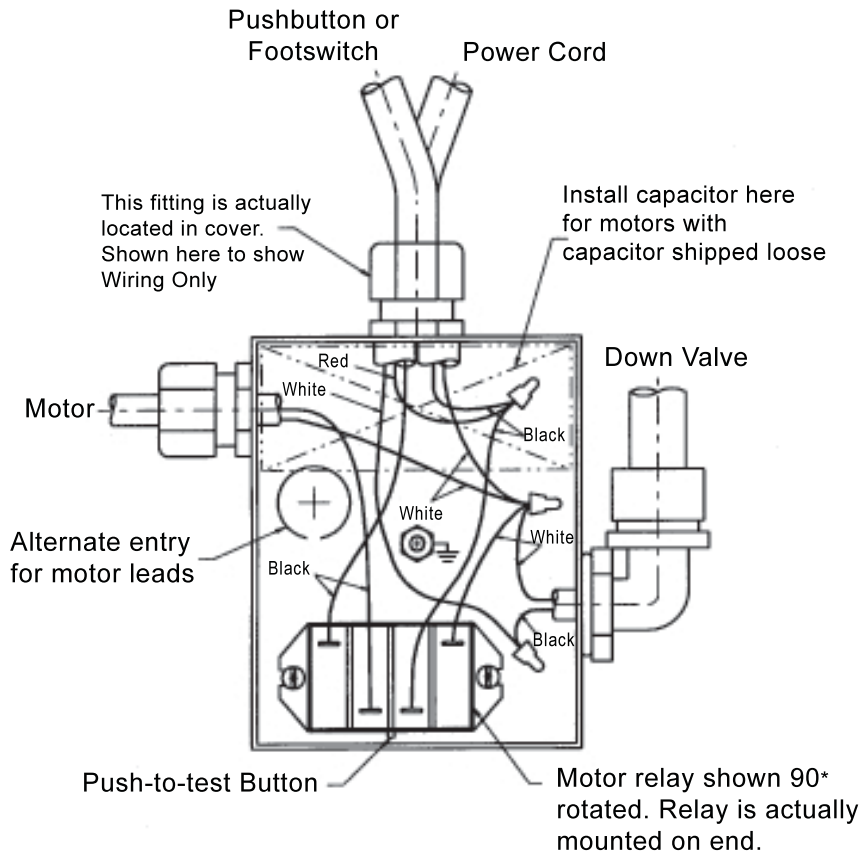

Figure 15 – Hydraulic Pump and Down Valve



NOTE:
Ground wires from motor, power cord, and pushbutton or footswitch are not shown for clarity. Attach all grounds to the enclosure grounding lug.

Figure 16 – Parts Identifications, Backsaver Lite

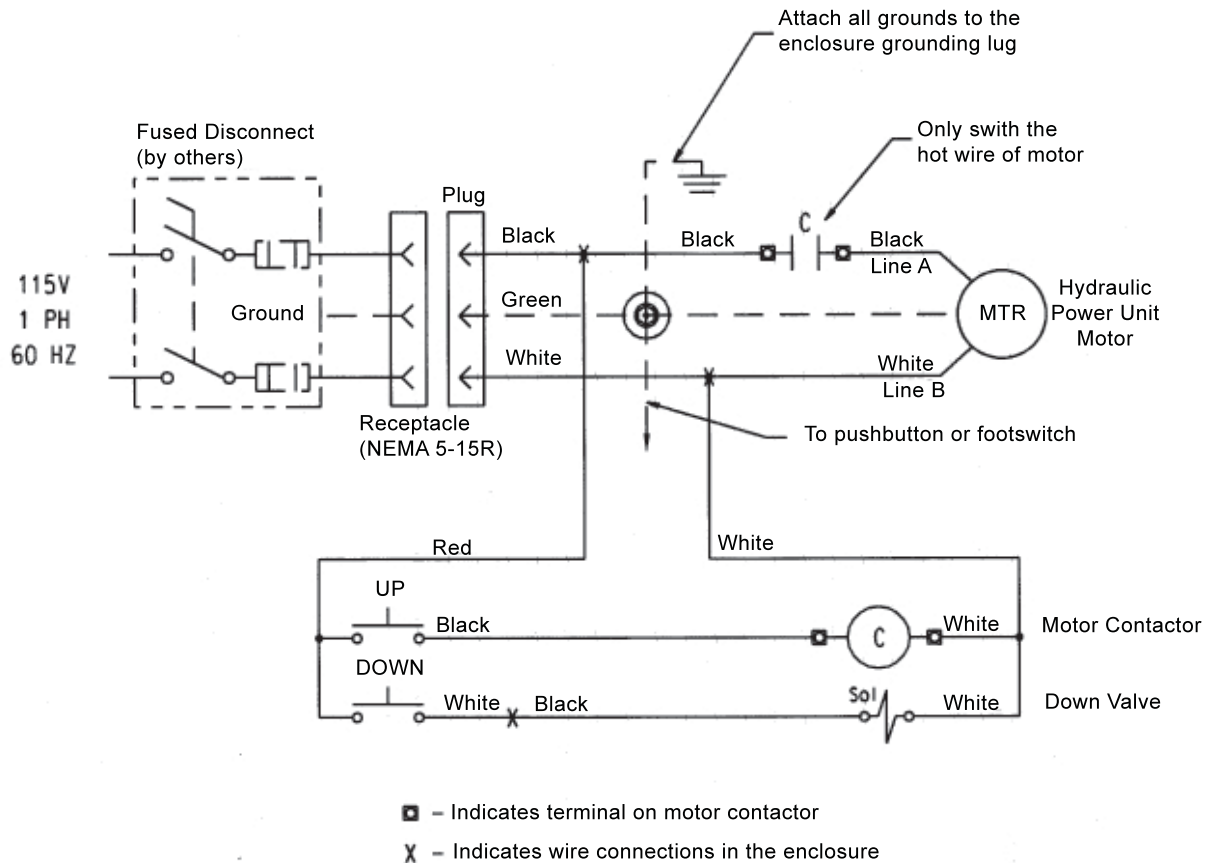

Figure 17 – Parts Identifications, Backsaver Lite

Electrical Connections for Single-Phase AC, continued

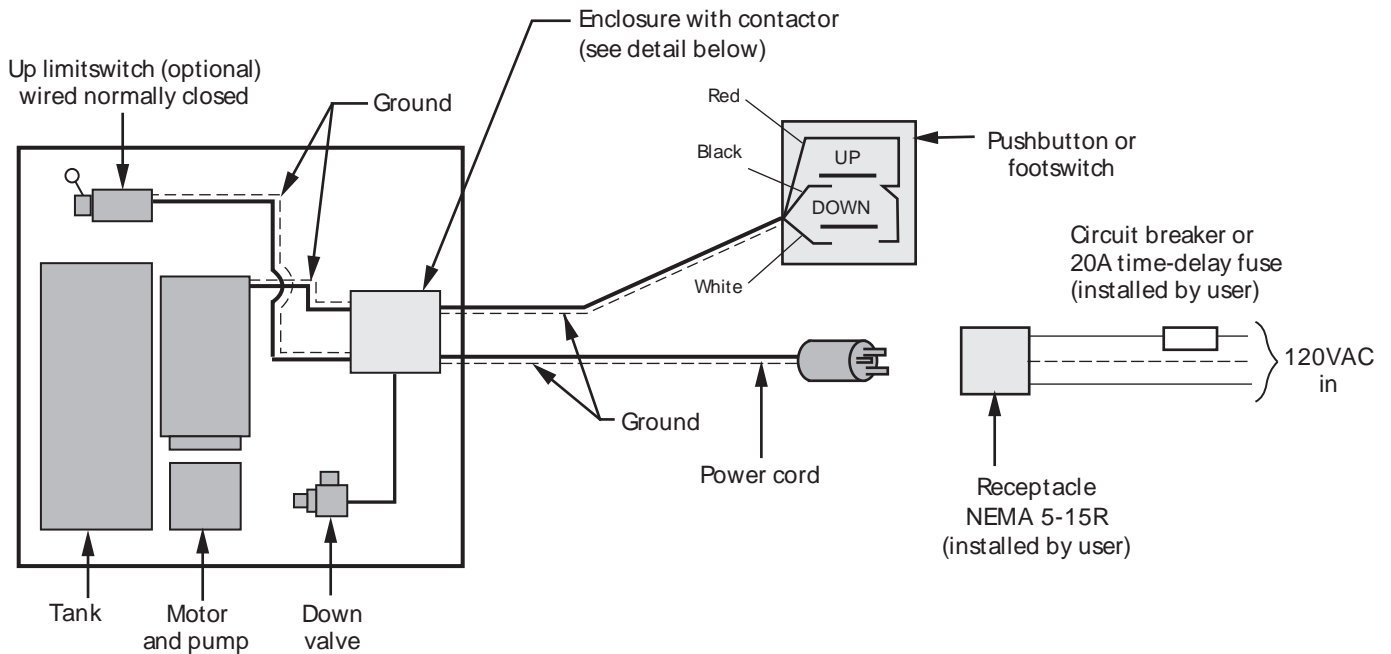

Figure 18 – Electrical Connections, Lifts Wired for Single-Phase AC

Connections shown above are for lifts operating on 120 VAC. For lifts operating on 230 VAC, a NEMA L6-15R receptacle is required. The pump, motor, and down valve may be mounted on the lift unit itself (internal power unit) or in a separate location (external power unit).

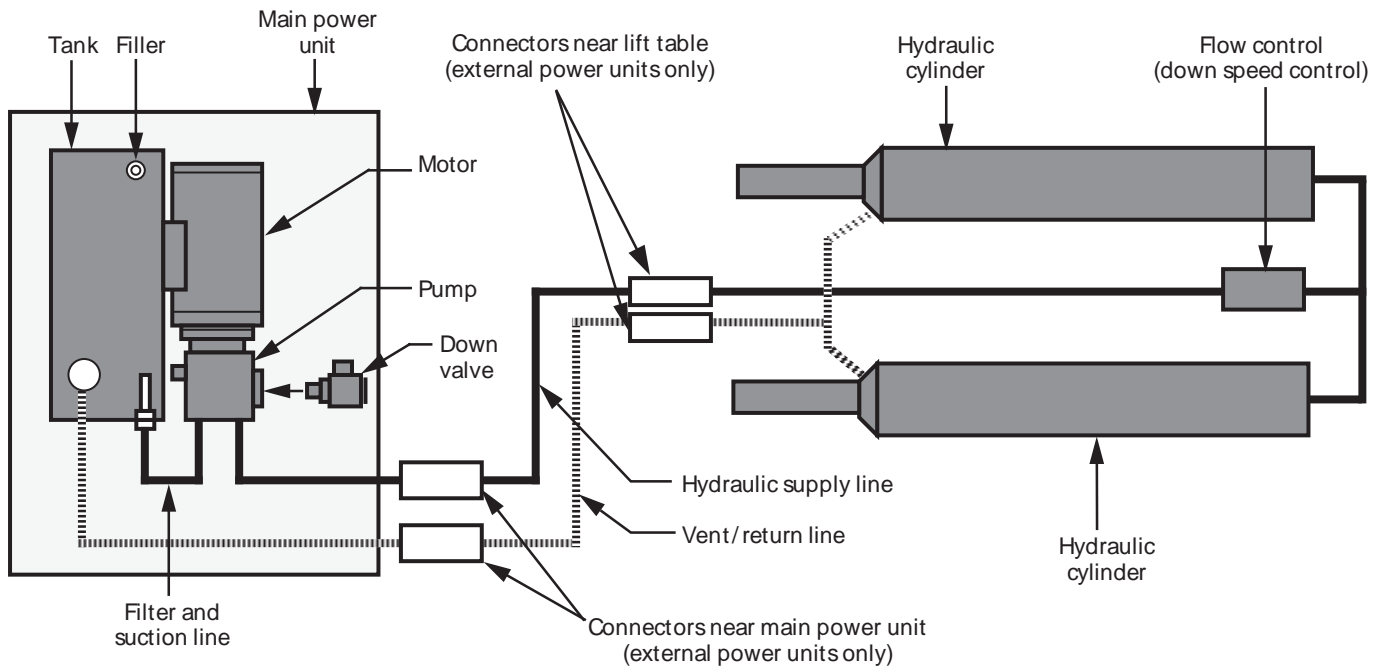

Figure 19 – Hydraulic Connections

Ordering Replacement Parts

Southworth has carefully chosen the components in your lift to be the best available for the purpose. Replacement parts should be identical to the original equipment. **Southworth will not be responsible for equipment failures resulting from the use of incorrect replacement parts or from unauthorized modifications of the machine.**

Southworth will gladly supply you with replacement parts for your Southworth lift. Key parts are identified in Figures 8 through 15. With your order, please include the model number and the serial number of the lift. You can find these numbers on the name plate, which is located on the crossbar at the base of the cylinder(s). When you are ordering parts for a cylinder, also include the cylinder number. This is stamped on the base of the cylinder housing.

To order replacement parts, please call the Parts Department.

Parts are shipped subject to the following terms:

- FOB factory
- Returns only with the approval of our parts department.
- Payment net 30 days (except parts covered by warranty).
- Freight collect (except parts covered by warranty).

Parts replaced under warranty are on a "charge-credit" basis. We will invoice you when we ship the replacement part, then credit you when you return the worn or damaged part.

Parts Department

Southworth Products Corp.

Telephone 207) 878-0700 or (800) 743-1000

FAX : (207) 797-4734

repairparts@SouthworthProducts.com

www.SouthworthProducts.com

Table 1 – Hydraulic Oil Specifications

If the lift will be used at normal ambient temperatures, Southworth supplies the unit with Citgo AW 32 oil. This may be replaced by any other good quality oil with 150 SSU at 100° F and rust and oxidation inhibitors and anti-wear properties.

If the lift will be used at ambient temperatures below 0°F, use aircraft hydraulic oil. Use Type 15 aircraft hydraulic oil.

The following are equivalent to CONOCO 32:

TYPE	MANUFACTURER
DTE 24	EXXON/MOBIL
NUTO H32	EXXON/MOBIL
AMOCO AW32	CHEVRON (AMOCO CO.)
AW32.....	CITGO

CAUTION!

It is very important to keep the hydraulic oil free of dirt, dust, metal chips, water, and other contamination. Most of the problems with hydraulic systems are caused by contamination in the oil.

2 YEAR WARRANTY

Southworth Products Corp warrants this product to be free from defects in material or workmanship for a period of **2 years** of single shift usage from date of shipment, providing claim is made in writing within that time period. This warranty shall not cover modified designs for special applications, failure or defective operation caused by misuse, misapplication, negligence or accident, exceeding recommended capacities, failure to perform required maintenance or altering or repairing, unless alteration is authorized by Southworth Products Corp. Except as set forth herein, there are no other warranties, express or implied, including the warranties of merchantability and fitness for a particular purpose, all of which are hereby excluded.

Southworth Products Corp makes no warranty or representation with respect to the compliance of any product with state or local safety or product standard codes, and any failure to comply with such codes shall not be considered a defect of material or workmanship under this warranty. Southworth Products Corp shall not be liable for any direct or consequential damages arising out of such noncompliance.

Southworth Products Corp's obligation under this warranty is limited to the replacement or repair of defective components at its factory or another location at Southworth Products Corp's discretion. This is buyer's sole remedy. Except as stated herein, Southworth Products Corp will not be liable for any loss, injury or damage to persons or property, nor for direct, indirect, or consequential damage of any kind, resulting from failure or defective operation of said product.

This warranty may be altered only in writing by Southworth Products Corp, Portland, Maine.

SOUTHWORTH

SOUTHWORTH PRODUCTS CORP

P.O. Box 1380, Portland, ME 04104-1380

Telephone: (800) 743-1000 • (207) 878-0700

Fax: (207) 797-4734

www.SouthworthProducts.com

SOUTHWORTH

We'll Show You How

Southworth is the world class supplier of products designed to improve productivity and enhance safety. Our staff has over 400 years of engineering experience. If one of our standard products does not meet your needs, our engineers can custom design equipment specifically suited to your material handling application.



Spring PalletPal Load Leveler



Lift with Flush Mount Turntable



Portable Container Tilters



Dock Lifts



Roll on Level Loaders



Portable Lifts



Stretchwrapping



Positioning

Floor to Mezzanine Lifts



Pallet Rotators



For more information, contact Southworth Products

Telephone (800) 743-1000 Fax (207) 797-4734

Email: salesinfo@SouthworthProducts.com