

Operating and Maintenance Manual

APCU Series All Purpose Container Unloader



Model #: APCU

Serial # _____

Placed in Service _____



Southworth Products Corp
P.O. Box 1380 • Portland, ME 04104-1380
Telephone: 207-878-0700 Fax: 207-797-4734

September 2005

Southworth Products Corp is widely acknowledged as the leading maker of hydraulic lifts and materials-handling equipment. Southworth machines are rugged and reliable, and are designed to provide years of trouble-free service. The designs are based on extensive engineering experience. These are good reasons for specifying Southworth machines in your plant.

Contents

INTRODUCTION	5
SAFETY	5
Safety devices	6
INSTALLATION INSTRUCTIONS	10
Preparation	10
Positioning the lift	10
Hydraulic connections	10
Electrical connections	11
Checking the hydraulic system	11
Testing	11
OPERATOR CONTROLS	12
OPERATING INSTRUCTIONS	12
MAINTENANCE	15
Hazards	15
Servicing the unit safely	15
Routine maintenance-weekly	15
Routine maintenance-monthly	16
Routine maintenance-6 months or 500 hours	16
TROUBLESHOOTING	17
ADJUSTMENT & REPLACEMENT PROCEDURES	22
Aligning the photo eyes	22
About the proximity switches	22
Setting end of travel for “tilt down” function	22
Setting end of travel for “tilt up” function	22
Setting end of travel for “dump up” function	22
Setting end of travel for “dump down” function	23
Inspecting and cleaning a control valve	23
Removing a cylinder	23
Repacking a cylinder	24
Replacing a cylinder	25
ORDERING REPLACEMENT PARTS	27
Return Policy	28
Warranty	30

List of Figures

Fig. 1	Overall View - Load Enclosure Lowered	6
Fig. 2a	Operating Sequence - Loading Position	7
Fig. 2b	Operating Sequence - Tilt 90 deg. Position	7
Fig. 2c	Operating Sequence - Dump Position	8
Fig. 3	Label positions	9
Fig. 4	Control panel	12
Fig. 5	Using the retainer bar	14
Fig. 6	Repacking the cylinder	24
Fig. 7	Hydraulic schematic	26
Fig. 8	Hydraulic power unit	26

Introduction

The Southworth All-Purpose Container Unloader (APCU) is designed to unload containers and pallets. APCU units are designed for tilting and dumping of equipment and materials in a general indoor industrial setting.

This manual contains instructions on the safe and proper installation, use, and maintenance of the All Purpose Container Unloader unit. Be sure that this manual is available to the people who install, use, or service the unit. Be sure that all personnel read this manual before they install, use, or service the unit.

The instructions in this manual are not necessarily all-inclusive, as Southworth cannot anticipate all conceivable or unique situations. **In the interest of safety, please read this whole manual carefully. Please understand the material in**

this manual before you install, use, or service the APCU unit. If you have any questions about any of the instructions in this manual, please contact Southworth Products Corp.

Southworth's product warranty is shown on the rear cover of this manual. This instruction manual is **not intended to be or to create any other warranty, express or implied, including any implied warranty of merchantability or fitness for a particular purpose, all of which are hereby expressly excluded.** As set forth more specifically in the product warranty, Southworth's obligation under that warranty is **limited** to the repair or replacement of defective components, which shall be the buyer's **sole remedy**, and Southworth shall not be liable for any loss, injury, or damage to persons or property, nor for any direct, indirect, or consequential damage of any kind resulting from the APCU unit.

Safety

Southworth is concerned about the safety of everyone who operates, maintains, repairs, or works near the APCU unit. The unit is a powerful machine with moving parts, and is capable of causing personal injury if proper precautions are not taken.

For this reason, throughout this manual, we have pointed out some of the hazards which may occur as you use the unit. We have also listed the instructions or precautions you should take to avoid these hazards. In some cases, we have also pointed out the consequences which may occur if you do not follow these instructions or precautions. We will use the following system to identify the severity of the hazards:

DANGER! – Immediate hazard which will result in severe personal injury or death.

WARNING! – Hazard or unsafe practice which could result in severe personal injury or death.

CAUTION! – Hazard or unsafe practice which could result in minor personal injury or property damage.

Please read and follow this instruction manual, including all safety instructions and precautions, carefully and completely.

Safety Devices

This unit has two kinds of safety devices. Guard fences protect each side of the unit. These are designed to keep everyone away from the moving parts of the unit while it is operating. These guards should always be in place when the unit is operating normally.

There may be some cases where you will want to do maintenance work with the safety guards removed. You should be especially careful during these procedures. As the load enclosure moves up and down, “pinch points” are created where the moving parts meet. If you are standing too close to the load enclosure when it is moving, your arm or leg may be caught in the moving parts, and you may be hurt. Stay away from the pinch points when the safety guards are removed and the load enclosure is moving. Always replace the safety guards as soon as you are done with the maintenance work.

The unit also includes two photo-eye systems. Each photo-eye system includes a light source on one side of the unit, and a reflector on the other side. If either of the light beams is broken, the unit will not start, and the load enclosure will not move. This helps to ensure that everyone is out of the way before the load enclosure moves.

Before using the unit, please be sure that the guards are in place, and that the photo-eye systems are working. If the guards are missing, or the photo-eyes are not working, turn off the machine right away and call a supervisor. Never operate the unit without these important safety features.

Figure 3 shows the positions of the warning labels on the unit. These labels have been included for your safety. If you find that the labels are worn or missing, or have been painted over, ask Maintenance to replace the labels before you use the unit.

Fig. 1 Overall View - Load Enclosure Lowered

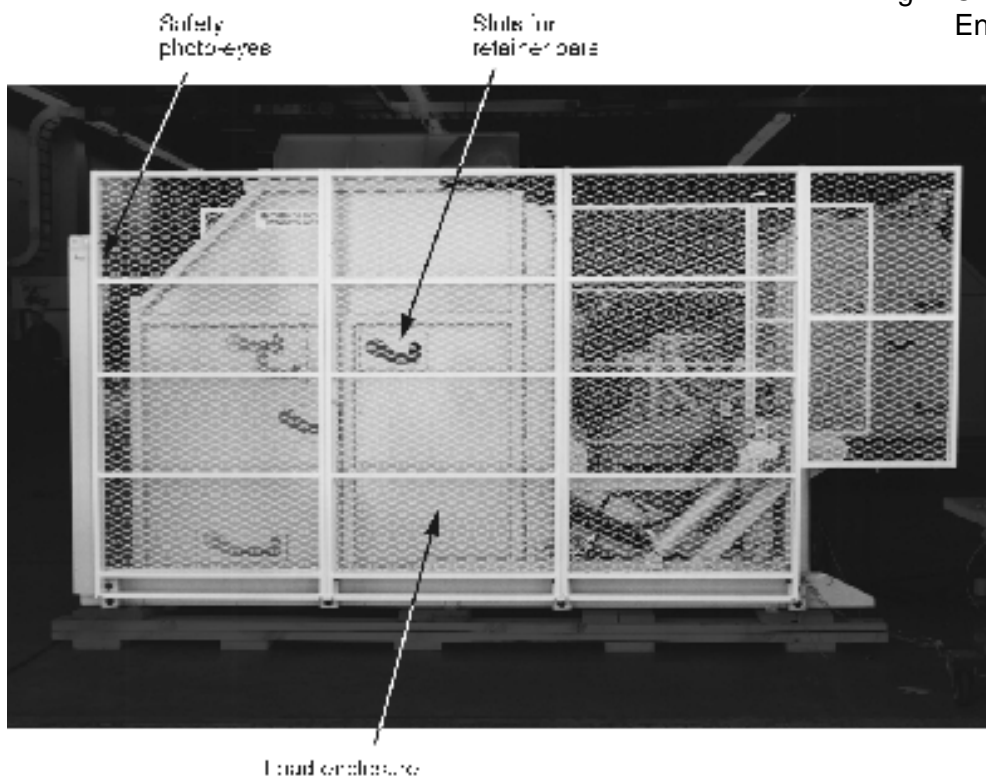

In this photo, the safety guards have been removed for clarity. You should never operate the unit with the safety guards removed. This machine is equipped with an external power unit, which is mounted a short distance away from the machine.

Fig. 2a Operating Sequence - Loading Position

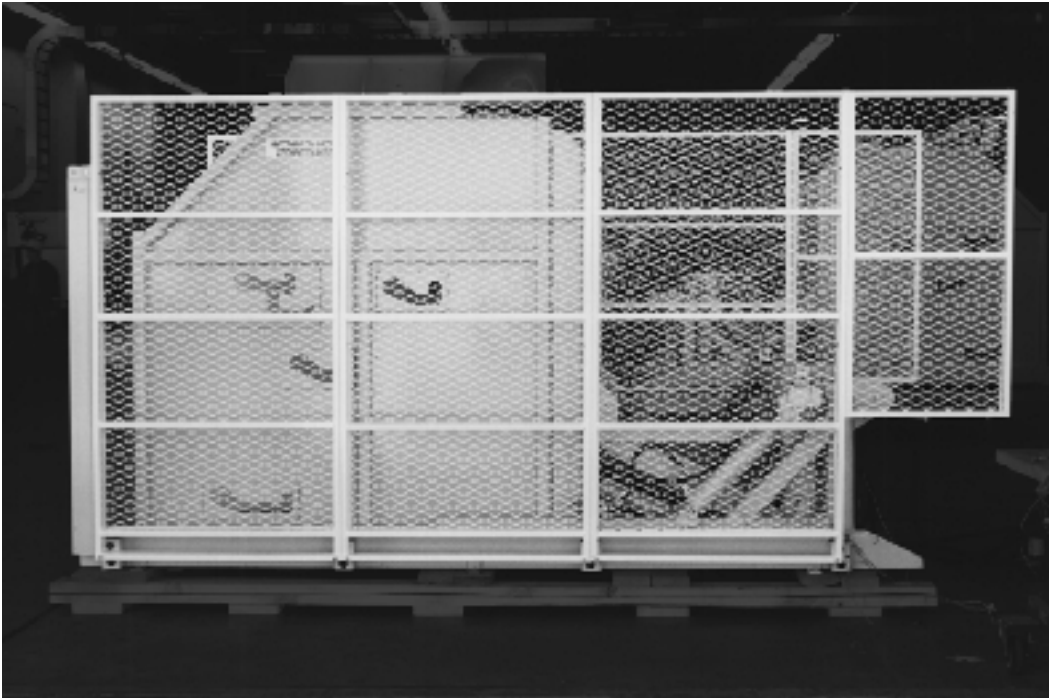

Fig. 2b Operating Sequence - Tilt 90 degree Position



Figure 2 shows the operating sequence for the unit. At the start of the process, the operator places the pallet or container on the load enclosure. This enclosure is positioned at ground level, so it is easy to load the unit. (See Part A of the illustration.) During the “tilt” part of the operating cycle, the load enclosure tilts up 90°. (See Part B.) Next, during the “dump” part of the cycle, the enclosure can be tilted an additional 50° to dump the items being loaded onto a conveyor or other device. (See Part C.)

This manual contains information about the safe and proper installation, use, and maintenance of

an APCU unit. Be sure that this manual is available to anyone who works with the unit. Be sure that everyone who uses the unit has read this manual.

The instructions included in this manual are not necessarily all-inclusive, because Southworth cannot anticipate all conceivable or unique situations. In the interest of safety, please read this whole manual carefully. Please understand the material in this manual before you install, use, or service the APCU unit. If you have questions about any of the instructions in this manual, please contact Rapistan Systems or Southworth Products Corp.

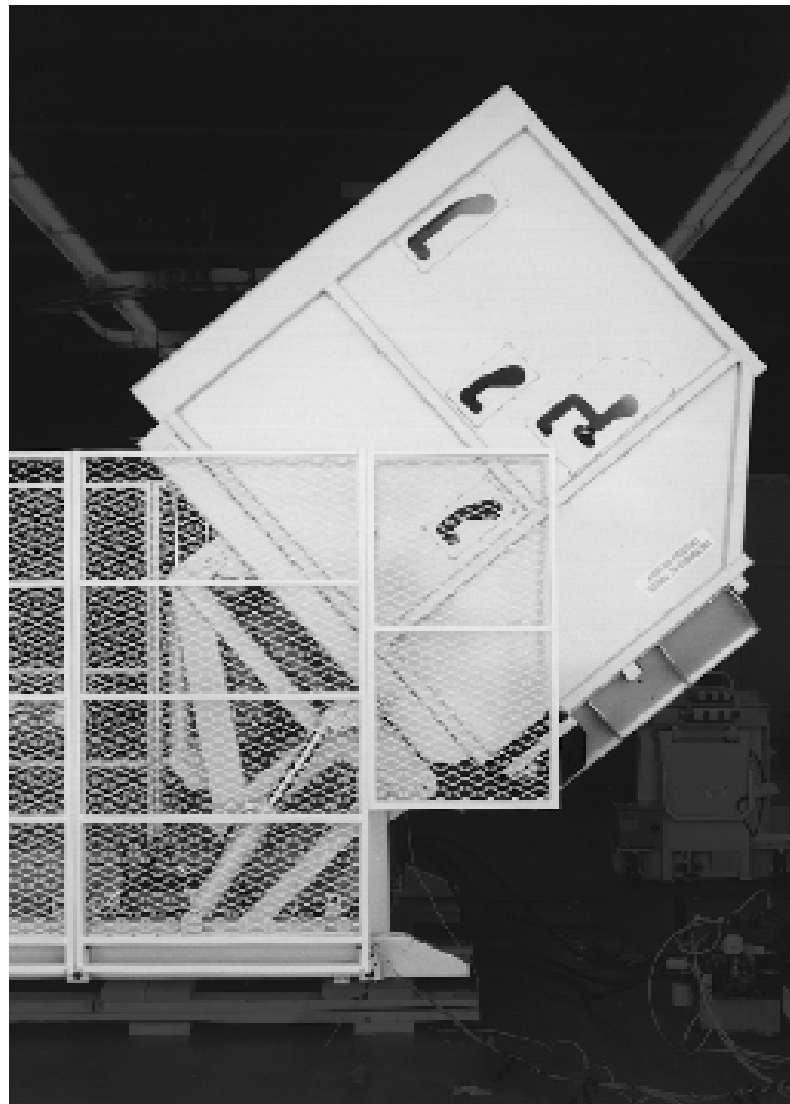

Fig. 2c Operating Sequence - Dump Position

OPERATING AND MAINTENANCE MANUAL

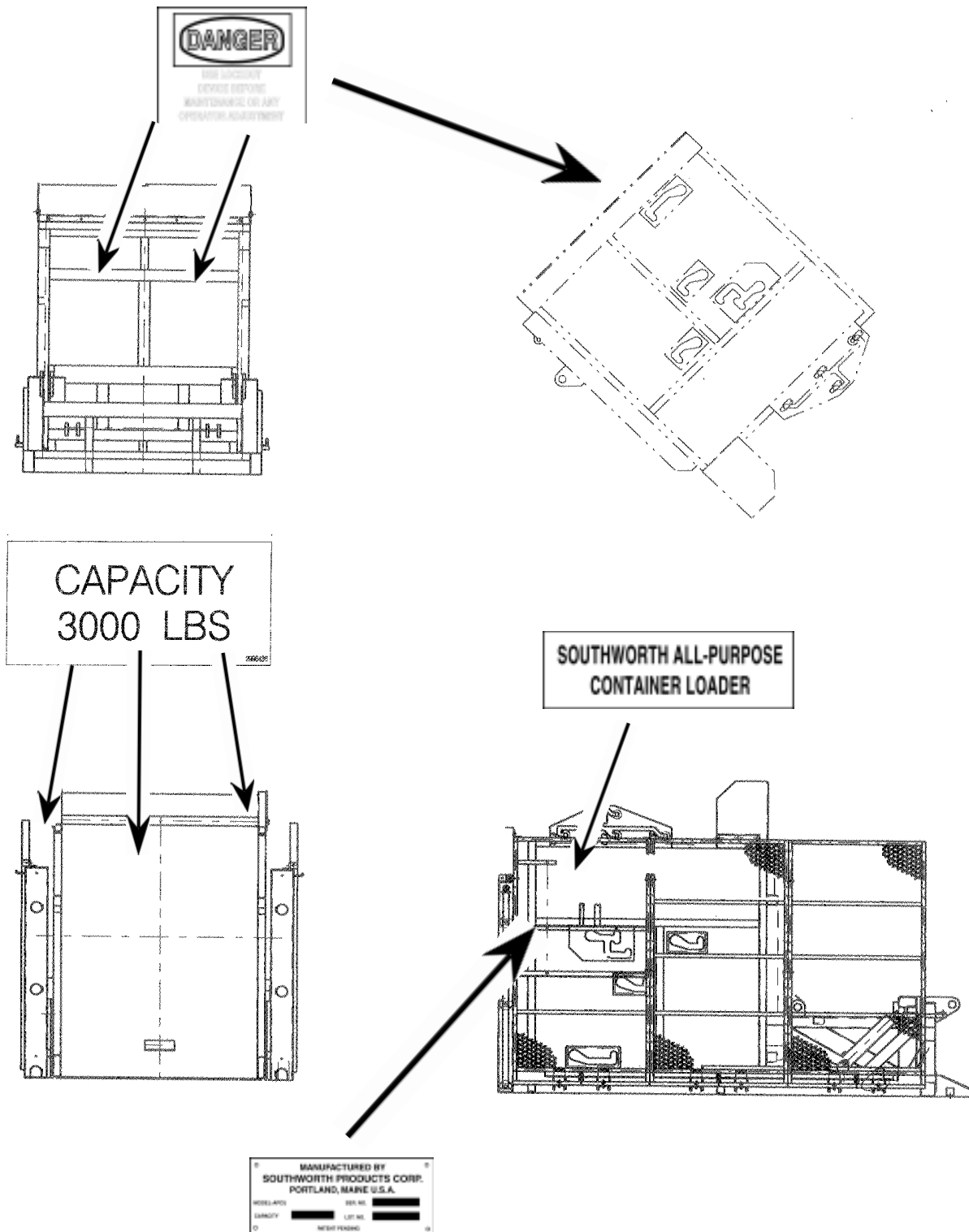

Fig. 3 Label Positions

Installation Instructions

Preparation

1. Before you start to use the unit, check for local codes and ordinances which may apply. It is your responsibility to obtain any necessary permits.
2. Read all of these installation instructions carefully. Be sure to read and understand all of the warnings.
3. Select the location where the unit will be installed. Choose a location where the floor is firm, flat and level. As the unit operates, it is very important that the front edge (the load edge) of the load enclosure touches the floor at the same time as the rest of the bottom plate touches.

CAUTION!

If the middle or back edge of the bottom plate touches the floor before the front edge of the load enclosure, the machine may try to tip itself off the floor. This can happen if the floor surface is not flat.

WARNING!

- **If the unit is mounted on an unstable surface, it may tip over when in use. You may be hurt, and the unit and load may be damaged.**
 - **Protect the unit from rain or moisture. If the electrical parts in the power unit get wet, workers may be hurt by electrical shock. The electrical parts may fail if they are wet.**
 - **The electric motor on the remote power unit can create sparks. Do not install the power unit in an area where flammable gases may be present.**
4. You will need these tools to install the unit:
 - A lift truck that can lift the unit safely.
 - Shims and appropriate lag bolts.
 - A masonry drill and bit to drill the holes for the lag bolts.
 - Extra hydraulic oil for flushing the hydraulic lines and refilling the tank.

Positioning the Lift

1. Remove the shipping material and unskid the unit. On the front of this manual, write down the model number, serial number, and date the unit is placed in service. You can find the model number and serial number on the name plate.
2. Move the unit into position, supporting the base of the unit. The base frame is fitted with eyes for the lag bolts. Drill the necessary holes and install the bolts.

CAUTION!

Do not hang the unit from the load enclosure. This can damage the unit.

3. Check the movement of the load enclosure through its full range.

CAUTION!

Take care not to create any “pinch points”.

Hydraulic Connections

1. Install the power unit. Run the hydraulic line between the power unit and the APCU but do not make the connections yet. Be sure that the hydraulic line is protected from passing traffic, and that it will not be damaged.

WARNING!

Be sure that the hydraulic line will not be pinched by the unit as it raises or lowers. If you allow the line to be pinched, the unit may not work properly. A hose may break, the load enclosure may drop suddenly, and someone may be hurt.

2. Before connecting the power unit, blow out the hydraulic lines with compressed air.

CAUTION!

It is very important to keep the hydraulic oil free of dirt, dust, metal chips, water, and other contamination. Most of the problems with hydraulic systems are caused by contamination in the oil. Be sure all hydraulic lines are free of contamination before connecting them to the remote power unit.

Electrical Connections

DANGER!

This unit requires three-phase 460V AC. This voltage can kill you. Don't work with the electrical parts unless you are a qualified electrician.

WARNING!

The fuses or circuit breakers are designed to reduce any fire hazard. Be sure to install the fuses or circuit breakers.

1. Because the unit is designed for three-phase AC, you must be sure the pump motor is turning in the right direction. The load enclosure should start to move quickly when you press the "up" or "down" button. If the load enclosure does not move in 2 or 3 seconds, don't try to operate the unit! Exchange any two of the three-phase leads. If this does not correct the problem, see the troubleshooting instructions at the end of this manual.

CAUTION!

The power unit is designed for three-phase AC. If you connect the power so the motor runs backwards, the load enclosure will not move, and you may damage the pump. Do not operate the unit for more than 2 or 3 seconds if you think the motor might be turning backwards.

Checking the Hydraulic System

1. Check the level of the hydraulic fluid in the system. With the load enclosure lowered completely, the hydraulic fluid can be checked by viewing the sight gauge on the reservoir of the power unit.

Testing

1. Clear the area around the unit. Remove any materials which might get in the way of the load enclosure as it raises or lowers. Be sure that the safety guards are in place on both sides of the unit.

2. Warn others to stay away from the unit. Operate the unit through its full range of travel. The load enclosure should rise smoothly with a quiet humming sound, and lower smoothly and quietly.

Raise and lower the load enclosure a few times to check the operation.

3. As the load enclosure lowers, notice how the bottom of the enclosure meets the floor. The front edge (load edge) of the enclosure should touch at the same time as any other part of the enclosure. If any other part of the base of the load enclosure touches before the front edge, the floor is not flat. Insert shims above the low spots on the floor, so that the base is flat and level.

WARNING!

If another part of the load enclosure touches the floor before the front edge, the machine may not stop automatically at the correct moment. This may cause the machine to try to lift itself off of the floor.

WARNING!

If the "Tilt Down" proximity switch is out of adjustment, the machine may continue to run when it should be stopped. This may cause the machine to try to lift itself off of the floor. This could cause damage to the unit.

4. As a final step, clean up all spilled hydraulic fluid. Spilled hydraulic oil is slippery, and may present a fire hazard. If you clean up any spilled fluid, you will be able to tell right away if the unit begins to leak.

Operator Controls

The control panel on the unit includes several standard controls. See Fig. 4. (This illustration shows the controls used on units produced for Rapistan Demag Corp.)

“Main Disconnect” Switch -

This switch controls all electrical power to the unit.

“Tilt Up” Button -

When the operator presses this button, the unit tilts the load enclosure 90°. See Part B of Fig. 2. Once the button is pressed, the machine will complete this part of the cycle - it is not necessary to hold the button.

“Dump Up” Button -

This button is used to unload the load enclosure. When the operator presses and holds the “Dump Up” button, the load enclosure begins to raise above the 90° tilt position. See Part C of Fig. 2. The load enclosure only moves when the operator is pressing the button. This allows the operator to move the load enclosure by small amounts to unload the load enclosure. (The “Dump Up” button will not operate until the load enclosure has reached the 90° tilt position.)

“Down” Button -

When the operator presses this button, the load enclosure lowers completely, back to the floor level. If the “Dump Down” button has been pressed, the unit begins by returning the load enclosure to the 90° tilt position. Next, the load enclosure lowers the rest of the way to the floor. Once the button is pressed, the machine will complete this part of the cycle - it is not necessary to hold the button.

“Emergency Stop” Switch -

In an emergency, the operator can press this button to stop the action of the load enclosure quickly. The unit will not operate again until the control system has been reset.

Safety Photo-Eyes (supplied) -

This machine has two photo-eyes positioned near the front of the frame. See Fig. 1. They are de-

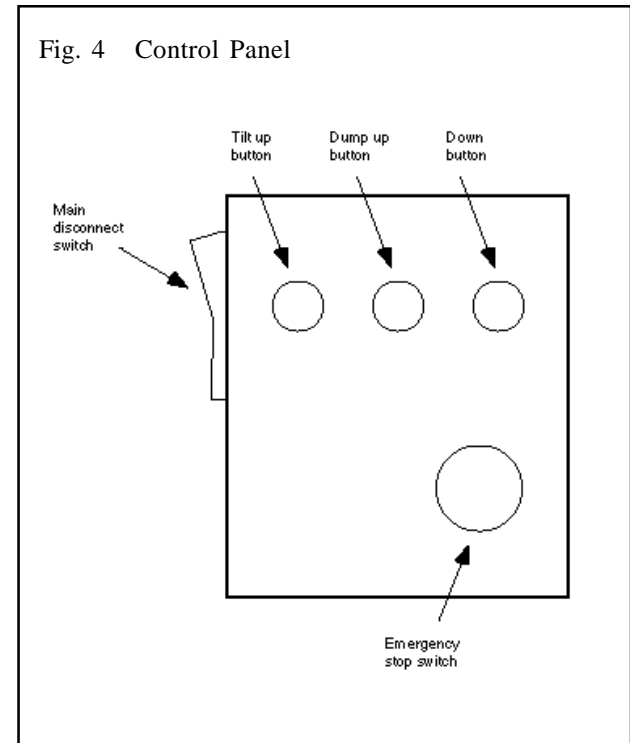

signed to provide a signal to stop the unit if one of the beams is broken. Before the machine will operate again, the control system must be reset, indicating that both photo-eyes are clear. Inspect the photo-eyes and verify their operation regularly.

Operating Instructions

1. Before operating the unit, please read all of this section. If your unit has any optional modifications or accessories, information on these will be included at the end of the manual.

DANGER!

The unit requires three-phase 460 Volts AC. This voltage can kill you. Do not work with the electrical parts unless you are a qualified electrician.

2. Check the area around the APCU to be sure it is clean and clear of obstructions. Be sure that the load enclosure will be able to travel freely through its full range.

3. Load the enclosure correctly:
 - Be sure that the load weighs no more than the maximum rated for the unit (2,000 lb.).
 - Lower the load enclosure completely.
 - Place the load as far back on the load enclosure as possible. Center the load in the side-to-side direction.

As you load the load enclosure, you will break one or both of the photo-eye beams at the front of the unit. See Fig. 1. As soon as you break either of the beams, the unit will be prevented from starting. When you are finished loading, the controls of the machine must be reset to return to a "Ready" condition. Be sure to back away from the front of the unit completely, so that the beams are not blocked.

4. As the load enclosure tilts, the top of the container or pallet will try to fall forward. See Fig. 5. To prevent this, you should install the retainer bar in the correct position on the unit. When you are loading the load enclosure, before it is tilted, the retainer bar should be set to hold the upper part of the container or pallet. (If the bar is set farther toward the back of the container or pallet, it may block some of the items as they fall free.) Notice that the bar will slide in the slots as the angle of the load enclosure changes.

WARNING!

Always place the retainer bar in the correct position before tilting the container or pallet. If you do not do this, the top of the container or pallet may fall forward. The items being loaded may be damaged. Never try to load the load enclosure while it is moving.

5. Before operating, be sure everyone is clear of the unit.

WARNING!

- **Do not try to lift a load that exceeds the maximum rating. If you try this, the unit may fail suddenly. Someone may be hurt, and the unit and load may be damaged.**
- **Never allow anyone to ride on the load enclosure while its moving.**

- **This unit includes two important kinds of safety devices. The guard fences on the sides of the unit are designed to keep anyone from touching the moving parts of the unit while it is operating. The photo eyes at the front of the unit are designed to stop the unit if anyone is standing in the way. Do not operate the unit unless both kinds of safety devices are in position and are functional.**

6. Operate the unit. Press the "Tilt Up" button. The load enclosure will tilt 90°. (The machine will complete this part of the cycle by itself - it is not necessary to hold the button.)

CAUTION!

If the unit does not operate right away, turn off the unit and call a qualified maintenance worker.

The next job is to dump the items being loaded onto the conveyor. To do this, press and hold the "Dump Up" button until the load enclosure dumps about half of the load. Once this has happened, press and hold "Dump Up" again to dump the rest of the load. (The "Dump Up" control will only operate while you are actually pressing it.)

CAUTION!

Avoid "bumping" the load enclosure into position by pressing the "Dump Up" control many times for short periods. This will cause the hydraulic equipment to wear much more quickly.

7. Once the load has been dumped, lower the load enclosure. Press the "Down" button. The load enclosure will lower to the "Tilt 90°" position, then lower the rest of the way to the floor. (Once you press the "Down" button, it is not necessary to hold it.)

During loading:

The retainer bar is placed above the rear edge of the container.

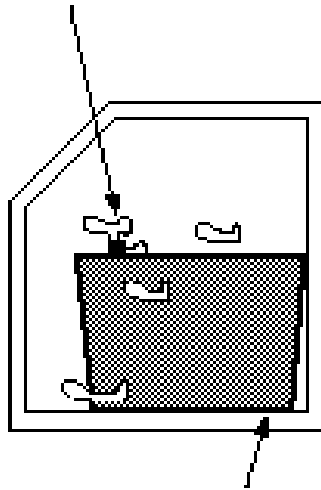

The container is placed as far back as possible.

The retainer bar is placed above the rear edge of the pallet.

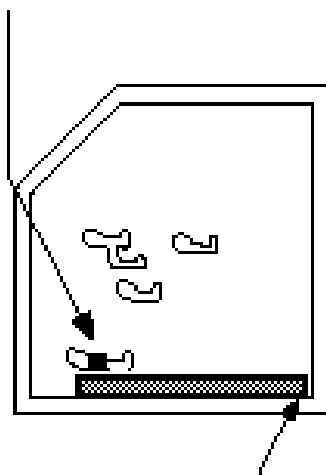

The pallet is placed as far back as possible.

During dumping:

The retainer bar holds the rear edge of the container.

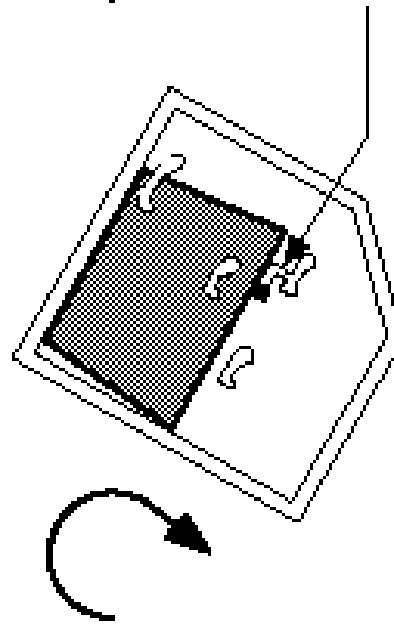

The retainer bar holds the rear edge of the pallet.

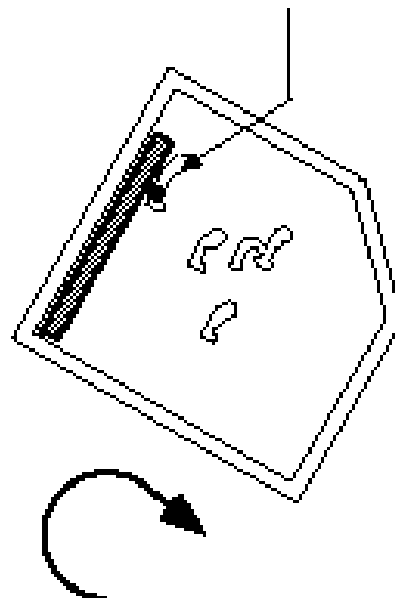

Maintenance

All servicing should be done by qualified personnel. Qualified personnel should be able to read and understand wiring and hydraulic diagrams. They should be able to troubleshoot live electrical circuits safely and in accordance with accepted practice. *For safety's sake*, if in doubt, please contact your dealer or Southworth Products Corporation Customer Service Department at (207) 878-0700.

Before servicing the unit, please read and understand all of this section and the section entitled "Operating Instructions."

Hazards

There are several hazards you should be aware of as you service the unit:

WARNING!

- **As the unit moves up and down, "pinch points" are created where moving parts meet. Keep hands, feet, and loose clothing away from these pinch points. If your hand or arm or a part of your clothing is caught, you may be hurt.**
- **Before performing any maintenance on the unit, lower the tilt platform completely. Failure to do so could result in severe personal injury.**
- **The relief valve has been included for the protection of all of the workers who use the unit. Don't change the relief setting! If the relief valve does not open when it should, the unit may fail. Someone may be hurt, and the unit and load may be damaged.**
- **If the hydraulic fluid is released under high pressure, it can cause personal injury. Before you open any part of the hydraulic system, be sure to release the hydraulic pressure. You can do this by lowering the tilt platform all the way down.**
- **The warning labels have been included for the safety of the operator. If the labels are worn or missing, or have been painted over, replace them**

before releasing the lift for operation. Fig. 1 shows the safety markings on this unit.

Servicing the Unit Safely

It is important to immobilize parts of the tilt and dump mechanisms before you service the unit. Please follow all of these steps whenever you work on the unit:

- Lower the load enclosure completely to the loading position. The cylinders and other parts can be removed safely from either the tilt or dump mechanisms when the load enclosure is completely lowered. Normally, you should never need to work under the load enclosure. Always stay clear of the space under this enclosure.
- Turn off the electrical power at the main disconnect or circuit breaker. Follow standard lock-out, tag-out procedures. Do not let anyone else use the controls on the unit.
- When you are finished, operate the machine, without a load, through at least one cycle. Be sure that it is operating smoothly and properly before returning it to regular operation.

Routine Periodic Maintenance

Every week:

- On the tilt mechanism and dump mechanism, check all of the hydraulic fittings and hoses, and repair as necessary. Sometimes the fittings can be worked loose by the vibrations in the hydraulic system.

WARNING!

If a hydraulic fitting becomes loose, or if a hydraulic hose breaks, the hydraulic fluid may escape from the system under pressure. If the load enclosure is elevated when this happens, this can cause it to drop. Someone may be hurt, or the unit or load may be damaged. Be sure all hydraulic fittings are free of leaks.

- Check the operation of the two photo eyes on the entry side of the machine. With the load enclosure in the fully lowered position, break the beam

of each photo eye. Here are the test conditions for the photo eyes:

Beam unbroken - LED on photoeye is lit.

Beam is broken - LED on photoeye is out.

When you break either beam, this should trigger a stop condition which requires the controls on the machine to be reset to return to "Ready" condition. The reflectors for the photo eyes should be replaced if they are cracked or otherwise damaged.

Routine Maintenance - Monthly

- On the tilt and dump mechanisms, inspect the main pivot pins and bushings and the cylinder clevis pins and bushings for signs of wear.

WARNING!

If you are going to repair the main pivot pins and bushings on either the tilt or dump mechanisms, you must return the load enclosure to the loading position.

- Apply grease to the grease fittings on the pivot and clevis pins.
- Check the level and appearance of the hydraulic fluid. When the load enclosure is fully lowered, the oil should be at the correct level as viewed through the sight glass on the reservoir. Add oil as necessary. Change the oil and filter if the oil has darkened, or feels gritty or sticky.

Routine Maintenance - Every six months or 500 hours of operation, whichever comes first:

- The hydraulic system includes a replaceable oil filter. Replace this filter as part of your routine maintenance. Inspect the oil, and replace it if necessary. If the oil is changed, thoroughly clean the reservoir, including the suction strainer.
- Be sure all of the warning labels are in position and legible. See Fig. 3. The warning labels are intended to protect your workers. If the

labels are missing, or if they have been painted over, replace them.

Troubleshooting

All servicing should be done by qualified personnel. Qualified personnel should be able to read and understand wiring and hydraulic diagrams. They should be able to troubleshoot live electrical circuits safely and in accordance with accepted practice. *For safety's sake*, if in doubt, please contact Southworth Products Corporation at (207) 878-0700.

Before servicing the unit, read and understand this entire section and the section entitled "Operating Instructions."

WARNING!

Before working under any raised parts of the unit, always lower the load enclosure to the floor. This will support the parts of the unit and relieve any hydraulic pressure in the system. If you do not do this, and attempt to work on the unit, you may be badly hurt and the unit may be damaged.

This unit has two lifting actions. Each of these lifting actions is provided by a separate pair of lifting cylinders:

- 90° tilting action - inner cylinders
- 50° dumping action - outer cylinders

Both sets of cylinders are powered by the same hydraulic power unit.

As you troubleshoot the unit, notice whether just one of the lift functions is not working, or all of the lift functions are not working.

Table 1 – Hydraulic Oil Specifications

If the lift will be used at normal ambient temperatures, Presto Lifts supplies the unit with Citgo AW32 oil. This may be replaced by any other good quality oil with 150 SSU at 100° F and rust and oxidation inhibitors and anti-wear properties.

If the lift will be used at ambient temperatures below 0°F, use aircraft hydraulic oil. Use Type 15 aircraft hydraulic oil.

The following are equivalent to CITGO AW32:

TYPE	MANUFACTURER
DTE 24	EXXON/MOBIL
NUTO H32	EXXON/MOBIL
AMOCO AW32	CHEVRON (AMOCO CO.)

CAUTION!

It is very important to keep the hydraulic oil free of dirt, dust, metal chips, water, and other contamination. Most of the problems with hydraulic systems are caused by contamination in the oil.

Symptom	Possible Cause	Remedy
Neither lift mechanism is working: CAUTION! If the tilt function does not begin right away, don't continue to operate the "up" control for more than 2 or 3 seconds. You may damage the pump.	The power for the unit may be switched off.	Turn on the "Main Disconnect" switch.
	The belt conveyor may not be operating.	The belt conveyor must be operating for the APCU to operate.
	One of the fuses or circuit breakers may have opened.	Replace the fuse, or reset the circuit breaker. If the condition repeats, determine the cause of the problem.
	The Emergency Stop switch may have been pressed.	Reset the Emergency Stop switch, and reset the control system.
	One of the protective light beams at the front of the unit may be blocked.	Be sure the space in front of the unit is clear.
	There may be a problem with one of the photo eyes.	Check the alignment of each photo eye and its reflector. When the eye can "see" the reflector, the LED on the photo eye should light. Check the power supply to the photo eye. Replace the part if it is faulty.
	The motor for the pump may have stopped. The motor controls have built-in overcurrent protection in case of an overload.	The protective circuit will reset after it has cooled. Look for anything which may be preventing the motor from turning.
	The motor may be running backwards.	If this is happening, the pressure valve will indicate zero pressure even though the motor is running. Reverse any two electrical leads on the motor.
	The motor may be "single phasing".	This causes the motor to hum, but not turn. Check for a break in one lead to the three-phase motor. Check the motor wiring and line fuses.

Symptom	Possible Cause	Remedy
	The motor may be running backwards.	If this is happening, the pressure valve will indicate zero pressure even though the motor is running. Reverse any two electrical leads on the motor.
	The motor may be “single phasing”.	This causes the motor to hum, but not turn. Check for a break in one lead to the three-phase motor. Check the wiring and line fuses.
	The voltage to the motor may be too low.	Check the voltage at the starter when the motor is under load. The supply voltage should be within $\pm 10\%$ of the rating.
	The level of the hydraulic oil may be low.	When the unit is lowered completely, check the oil level by viewing the reservoir sight gauge.
	The filler/breather cap on the hydraulic tank may be plugged.	Remove the cap and clean the baffles inside it.
	There may be a vacuum leak in the suction line. (This could cause cavitation and loss of suction in the pump.)	Check the suction line hose and fittings. Caution! Do not allow cavitation to continue - this may damage the pump.
	The coupling between the pump and motor may be missing.	Remove the pump as described in this section. Check to see that the coupling is in place.
The tilt mechanism will not raise.	The up-proximity switch for the tilt lift function may be out of adjustment.	Check the adjustment of the switch. (See the section on “Adjustment and Alignment”.)
	The “up” side of the control valve for this function may not be working.	The “up” side of the valve must be energized and fully open. Check the solenoid on the “up” side of the valve with a voltmeter. Check for a problem with the wiring to the control valve. The valve must be clean and free to operate. Release the pressure from the system and clean the valve. (See the section on “Inspecting and Cleaning a Control Valve”.)

Symptom	Possible Cause	Remedy
The tilt mechanism raises slowly.	The counter-balance valve in this circuit may be plugged.	Release the pressure from the system and clean the valve.
The tilt mechanism does not lower. Warning! Before working under any raised parts of the unit, support the body of the unit using a set of strong supports.	The “down” side of the control valve for this part of the system may not be working.	The “down” side of the valve must be energized and fully open. Check the solenoid on the “down” side of the valve with a voltmeter. Check for a problem with the wiring to the control valve. The valve must be clean and free to operate. Release the pressure from the system and clean the valve. (See the section on “Inspecting and Cleaning a Control Valve”.)
When the load enclosure is lowered, the center or rear touches the floor before the front edge (load edge).	The floor is not flat.	Insert shims above the low spots in the floor. The base frame of the machine must be flat and level.
The pump motor continues to run after the front edge (load edge) of the load enclosure touches the floor.	The proximity switch for the “Tilt Down” function may be out of adjustment.	Adjust the position of the target for this switch.
The “Tilt Down” part of the cycle begins prematurely.	The tilt frame may be hitting the stop pads at the upper limit of travel too hard.	Adjust the position of the target for the “Tilt Up” proximity switch.
The dump mechanism will not raise.	The up-proximity switch for the dump lift function may be out of adjustment.	Check the adjustment of the switch. (See the section on “Adjustment and Alignment”.)
	The “up” side of the control valve for this function may not be working.	The “down” side of the valve must be energized and fully open. Check the solenoid on the “down” side of the valve with a voltmeter. Check for a problem with the wiring to the control valve. The valve must be clean and free to operate. Release the pressure from the system and clean the valve. (See the section on “Inspecting and Cleaning a Control Valve”.)

OPERATING AND MAINTENANCE MANUAL

Symptom	Possible Cause	Remedy
The dump mechanism raises slowly.	The counter-balance valve in this circuit may be out of adjustment.	Release the pressure from the system and clean the valve.
The pump motor continues to run after the load enclosure has reached the upper limit of the dump travel.	The "Dump Up" proximity switch may be out of adjustment.	Check the adjustment of the switch. (See the section of "Adjustment and Alignment".)
The dump mechanism does not lower.	The "down" side of the control valve for this part of the system may not be working.	The "down" side of the valve must be energized and fully open. Check the solenoid on the "down" side of the valve with a voltmeter. Check for a problem with the wiring to the control valve. The valve must be clean and free to operate. Release the pressure from the system and clean the valve. (See the section on "Inspecting and Cleaning a Control Valve".)
The dump mechanism lowers slowly.	The counter-balance valve in this circuit may be plugged.	Release the pressure from the system and clean the valve.
At the end of the cycle, the load enclosure drops onto the base frame.	The proximity switch for the "Dump Down" function may be set too high. When the motor is shut off, this allows the load enclosure to drop.	Check the adjustment of the switch. (See the section on "Adjustment and Alignment".)

Adjustment and Replacement Procedures

Aligning the Photo-Eyes:

1. The photo-eyes are part of a system which protects the operators from moving parts which are potentially dangerous. If an operator moves close to the loading end of the machine, and breaks either of the light beams, the unit will stop immediately. The unit will not run again until the control system has been reset. Each eye sends a light beam to a matching reflector. The beam is then returned to the light sensor.
2. When the machine is turned on, check the LED indicator on the side of the photo-eye. If the photo eye is properly aligned and is not blocked, with the beam returning from the reflector, the LED will light. If the photo-eye cannot see the reflector, or the beam is blocked, the LED will be out. If necessary, move the reflector until the LED lights.
3. If the LED will not light, yet the reflector seems to be aligned, check that the proximity switch is receiving power.

About the Proximity/Limit Switches:

1. On this machine, proximity switches are used as limit switches. Each switch has two parts - a sensor and a target. Each switch is a "normally open" type.
2. The nominal distance between each sensor and its target is 3/16". If the sensor can see the target, the LED on the side of the sensor will light. If necessary, change the alignment of the target or sensor until the LED lights.
3. If the LED will not light, yet the target seems to be aligned, check that the photo-eye is receiving power.

Setting End of Travel for "Tilt Down" Function:

This proximity switch is located on the mid-point of one side of the machine base. The target for this switch is located on the bottom back outside corner of the load enclosure.

1. Set the unit so that the loading edge of the load enclosure is touching the floor.

WARNING!

If any part of the base plate contacts the floor, except for the front lip, you must shim the base of the machine.

2. Position this switch so that the load enclosure stops lowering when the front lip of the load enclosure just contacts the floor. When the load enclosure reaches this limit, the switch should send a signal to stop the motor on the hydraulic power unit.

WARNING!

If the motor continues to run after the front of the load enclosure touches the floor, the unit may try to lift itself off of the floor. This can damage the machine. To correct this problem, move the target so that it activates the switch sooner.

Setting End of Travel for "Tilt Up" Function:

This proximity switch is located on the top outside edge of the tilt frame. It is positioned close to the discharge end of the machine. The target for this switch is located on the top back outside edge of the load enclosure.

1. Set this switch so that the tilt function of the load enclosure stops just as the frame of the load enclosure hits the stop pads, or just a moment before. When the load enclosure reaches this limit, the switch should send a signal to stop the motor on the hydraulic power unit. A clearance of 1/8" from the pads is acceptable.

WARNING!

If the frame of the load enclosure is allowed to hit the stop pads with too much force, it will have an erratic motion. It may even bounce off of the pads and begin the "Tilt Down" part of the cycle by itself.

Setting End of Travel for "Dump Up" Function

This proximity switch is located on top of the back upright tube of the base frame. The target for this switch is located on the top back side of the tilt frame.

1. Position this switch so that the load enclosure stops dumping at the desired angle.

When the load enclosure reaches this limit, the switch should send a signal to stop the motor on the hydraulic power unit.

WARNING!

If the motor continues to run after the dump motion should stop, the machine may be damaged. Move the target so that the motor stops at the point where the dump motion should stop.

Setting End of Travel for "Dump Down" Function: This proximity switch is located on top of the base tube of the base frame, toward the dump side of the machine. The target is located on the bottom back outside of the tilt frame.

1. Position this switch so that, at the end of the "Dump Down" cycle, the bottom of the tilt frame rests on the cross tube at the dump end of the base frame. The tilt frame must be supported by the base frame when it is in the down position. This switch must be activated when the bottom stop pads of the tilt frame are as close as possible to the base frame. The distance should be 1/8" or less.

WARNING!

If this switch activates too soon, the tilt frame will stop before it reaches the base frame. When the hydraulic power unit is switched off, the tilt frame will drop onto the base frame and cause erratic motion of the load enclosure.

Inspecting and Cleaning a Control Valve

1. Check that the valve is receiving the correct control voltage. When the valve is supposed to be energized, the solenoid should receive 24V DC.
2. Check the continuity through the solenoid coil. With the power off, check the resistance through the coil using an Ohmmeter. There should be a low resistance (a few Ohms). If the meter shows no resistance, the coil may be shorted. Substitute a coil which is known to be good. If the meter shows an infinitely high resistance, the coil should be replaced.
3. Each valve used on this machine is designed with a solenoid coil which can be changed without removing the valve or spilling any hydraulic fluid. To change the solenoid:

- Disconnect the wire leads to the solenoid.
 - Loosen the knurled nut at the top of the solenoid, and remove the nut and O-ring.
 - Slide the solenoid off of the core tube.
4. To clean the parts on the valve spool, you must remove it from the valve body. De-pressurize the hydraulic system by lowering both lifting mechanisms completely. Be sure to turn off the power to the machine.
 5. Unscrew the core tube. Remove the valve plunger and inspect it for dirt or metal chips which could block the valve action. Clean the valve plunger as required, then blow it clean with compressed air. Before reassembly, verify that the inside of the valve body is clean and free of debris. Depress the plunger by hand several times to be sure it moves freely.
 6. To reassemble, reverse the steps listed above. The nut which holds the solenoid should be finger-tight only!

Removing a Cylinder

This section will tell you how to remove a cylinder from the tilt mechanism or the dump mechanism. Two cylinders are used on each mechanism. Both types of cylinders are double-acting, and both have the same bore diameter. The following procedure will apply to both cylinder types.

Before beginning this procedure, please read and understand this entire section.

WARNING!

Before removing the cylinder from either mechanism, lower the load enclosure completely to the loading position. See the section "Servicing the Unit Safely" before starting work.

1. Before you remove a cylinder, be sure that you have these items on hand:
 - Replacement cylinder or cylinder packing kit.
 - A supply of new hydraulic oil. Contaminated oil may damage the new packing.
 - Containers to catch the used oil.
 - A clean place to work which will not be damaged if you spill some oil (especially if re-

- packing the existing cylinder).
2. Lower the load enclosure completely to the loading position (as discussed earlier).
 3. Turn off the electrical power at the main disconnect or circuit breaker. Follow standard lock-out/tag-out procedures.
 4. Disconnect the hydraulic supply line to the bottom end of the cylinder. Place the free end into a container to collect the used oil.
 5. Repeat the same procedure for the hydraulic supply line to the top end of the cylinder.
 6. At the top end of the rod remove the "keeper" from the upper cylinder clevis and drive out the upper clevis pin. Repeat the same procedure to remove the lower cylinder clevis pin.
 7. Push the rod back into the cylinder to drive the hydraulic fluid out through the hose and into the container. You may use air pressure at the hydraulic port to do this.
 8. Now the cylinder can be removed for repacking or replacement.

CAUTION!

The cylinder is heavy! Be careful not to drop it as it comes free!

Repacking a Cylinder**CAUTION!**

Repacking the cylinders requires special training and tools. If you are not familiar with repacking procedures, this work should be left to a qualified hydraulic repair shop.

1. Begin by removing the cylinder as described in the last section.
2. Figure 6 shows the parts inside a cylinder. Secure the cylinder in a vise so that it cannot turn. Clear the work area so that you can lay the parts on a clean surface.
3. At the upper end of the cylinder, remove the snap ring. Pull the rod to within 3 inches of full extension. Compress the ring and, at the same time, pull outward on the rod. This will pull the gland out of the cylinder.
4. Pull the rod and piston all of the way out of the

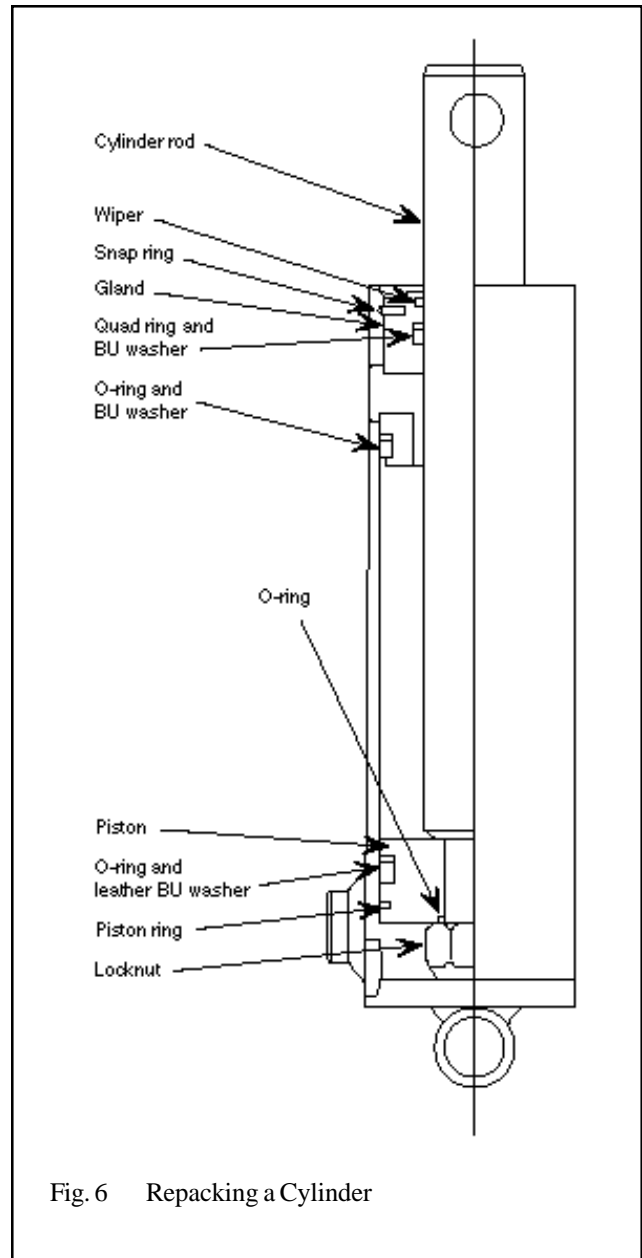

Fig. 6 Repacking a Cylinder

5. cylinder. This assembly is heavy! Be careful not to drop it as it comes free.
5. Remove the piston from the cylinder rod. (Be careful to protect the cylinder rod as you do this. Any burrs on the rod could damage the packing.) Note the position of the piston ring and remove it. Remove the leather BU washer and larger O-ring from the piston. Remove the smaller O-ring which fits around the cylinder rod.

6. Remove the gland from the cylinder rod by sliding it off of the end which holds the piston. Notice how the wiper ring sits in the gland. Note the positions of the quad ring and BU washer. Remove the wiper ring, quad ring and BU washer from the gland.

CAUTION!

During reassembly, it is very important to keep all of the parts free of dirt, dust, metal chips, water, and other contamination. Most of the problems with hydraulic systems are caused by contamination in the oil.

7. Clean all of the surfaces on the gland. Install a new quad ring and BU washer. Install a new wiper ring in the correct orientation. Coat the inner diameter of the gland with light grease and replace it on the rod.

CAUTION!

Be careful not to install the wiper backwards.

8. Clean the piston surfaces. Install a new larger O-ring and leather BU washer on the piston. Install a new piston ring. Install a new smaller O-ring. Attach the piston to the rod and tighten the large nut.
9. Clean the bore of the cylinder tube thoroughly. Inspect the bore of the tube for scratches which run up and down, along the length of the cylinder. If you do see any scratches, hone the inner surface of the cylinder. Be sure to clean the tube thoroughly after you do this.
10. Lubricate the inner diameter of the cylinder tube with a light coating of hydraulic oil. Carefully insert the piston and rod back into the cylinder. Be very careful not to damage the piston ring, O-ring or BU washer as you do this. It may be helpful to tip the rod assembly and twist it as you slide it into the cylinder. Once the piston is inside the cylinder, it should slide easily.
11. Slide the gland assembly into the cylinder. Rotate the gland so the port lines up with the hole in the cylinder tube. Install a new snap ring. Compress the snap ring, tap the gland into place, then relax the snap ring. Be sure that the snap ring is in place in the groove.
12. Install the cylinder in the unit as described below.

Replacing a Cylinder

Before beginning this procedure, please read and understand this entire section.

1. Before beginning, read steps 2 through 4 in the procedure "Removing a Cylinder" listed above.
2. Place the cylinder near the point where it will fit into the mechanism. Be sure the cylinder ports are oriented correctly.
3. Align the lower cylinder with each lower cylinder clevis and insert the lower cylinder clevis pin. Be careful! The cylinder is heavy! Replace the "keeper" and secure it with the button-head cap screws (supplied). Repeat the same procedure to replace and secure the clevis pin for the upper cylinder.
4. Attach the lower and upper hydraulic supply lines.
5. Be sure everyone is clear of the equipment. Turn on the power and test the unit. Run the mechanism through a couple of cycles to completely purge any air trapped in the hydraulic lines.

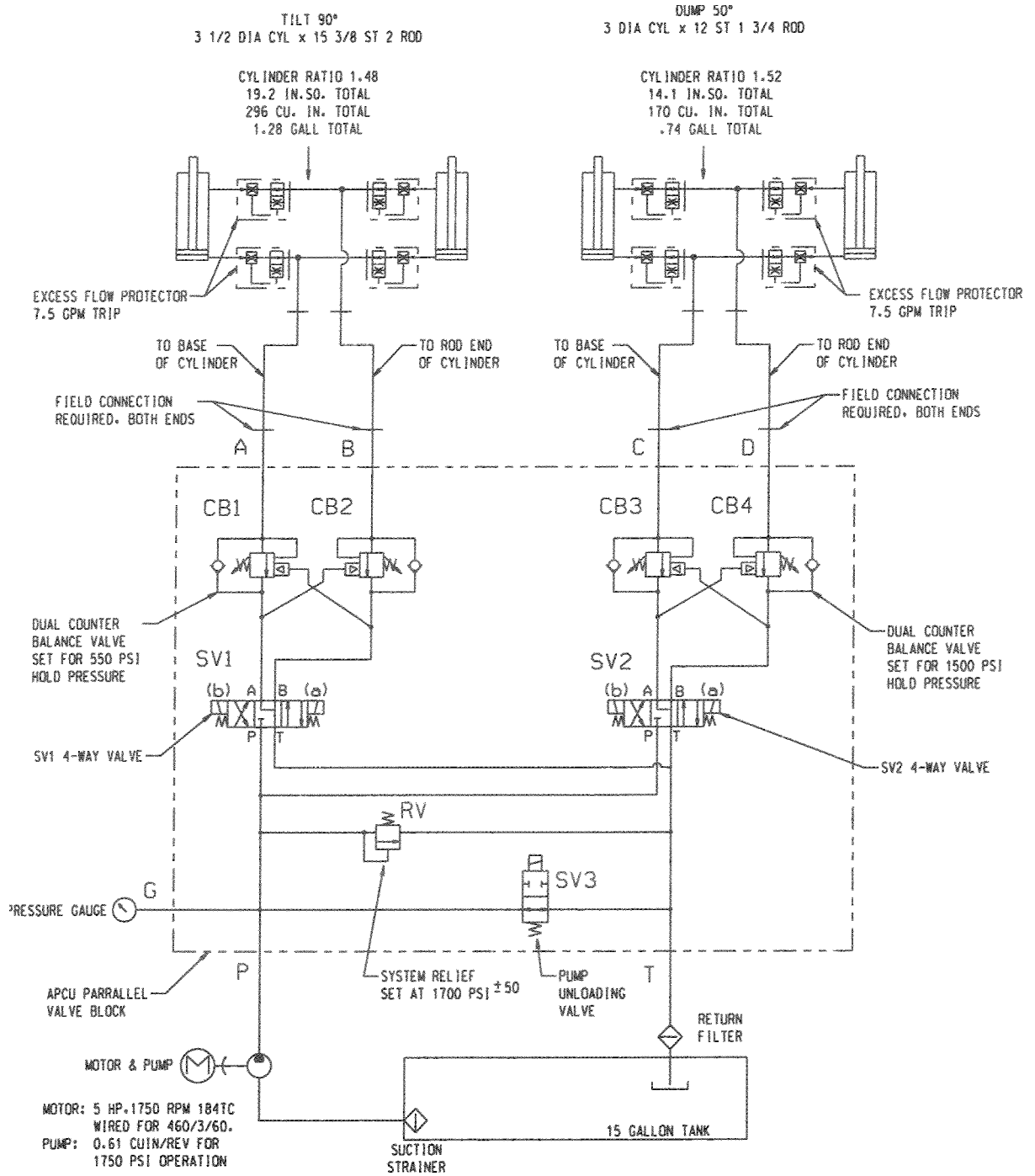
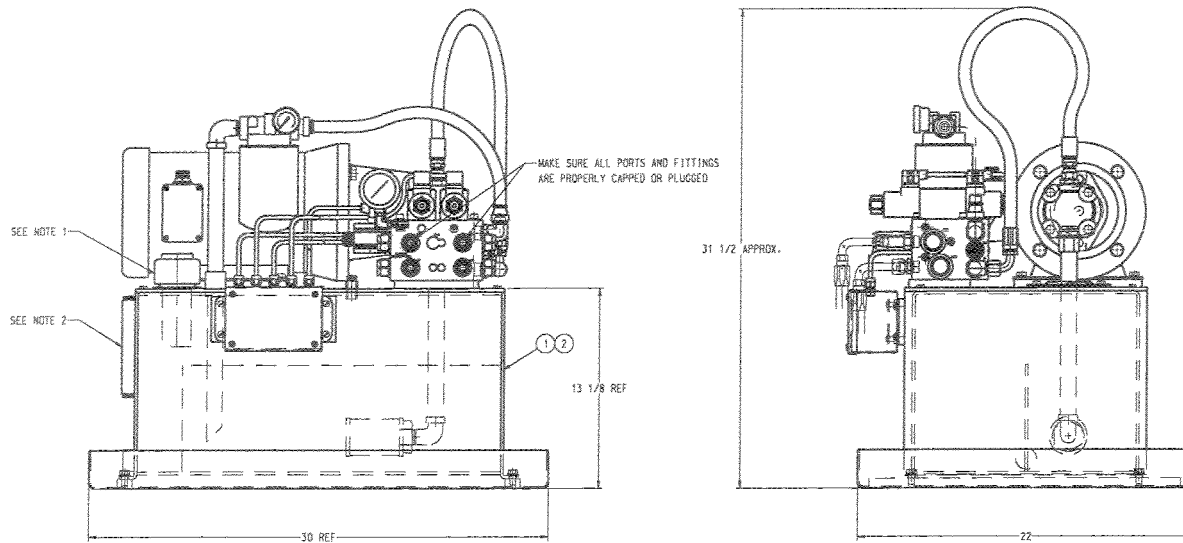

Figure 7 Hydraulic Schematic



HYDRAULIC POWER UNIT SPECIFICATIONS

- MOTOR:** Baldor: 5HP, 1750 RPM 208/230 - 460V / 3 / 60, 184TC wired for 460.
- PUMP:** Parker gear pump: 0.61 CUIN / Rev with pump adapter and flex coupling for 1750 PSI operation.
- RESERVOIR:** 15 gallon with suction strainer, return filter and drip pan.
- VALVE MANIFOLD:** Parker 2-station parallel manifold with system relief valve, dual counter balance valves and pump unloading valve.
- PRESS GAUGE:** 0 - 2,000 PSI

NOTES:

1. Cleanliness of inside of hydraulic tank must be maintained at all times. Wipe inside of tank clean of all loose debris, metal chips, dust and dirt. Inside of tank must be dry and free of moisture before adding hydraulic oil.
2. Fill tank to the proper level indicated on tank level / temperature gauge before operating system. Be sure not to overfill and thoroughly clean any spills.

Figure 8a. Hydraulic Power Unit

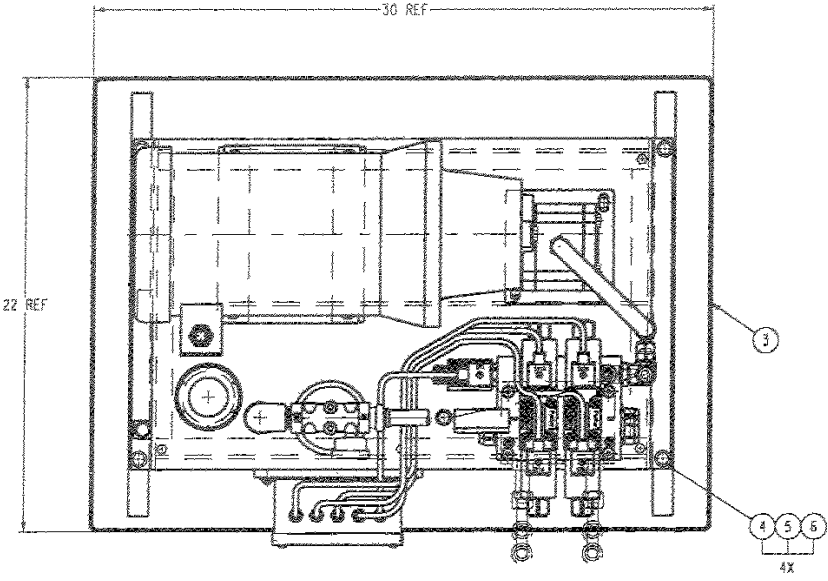
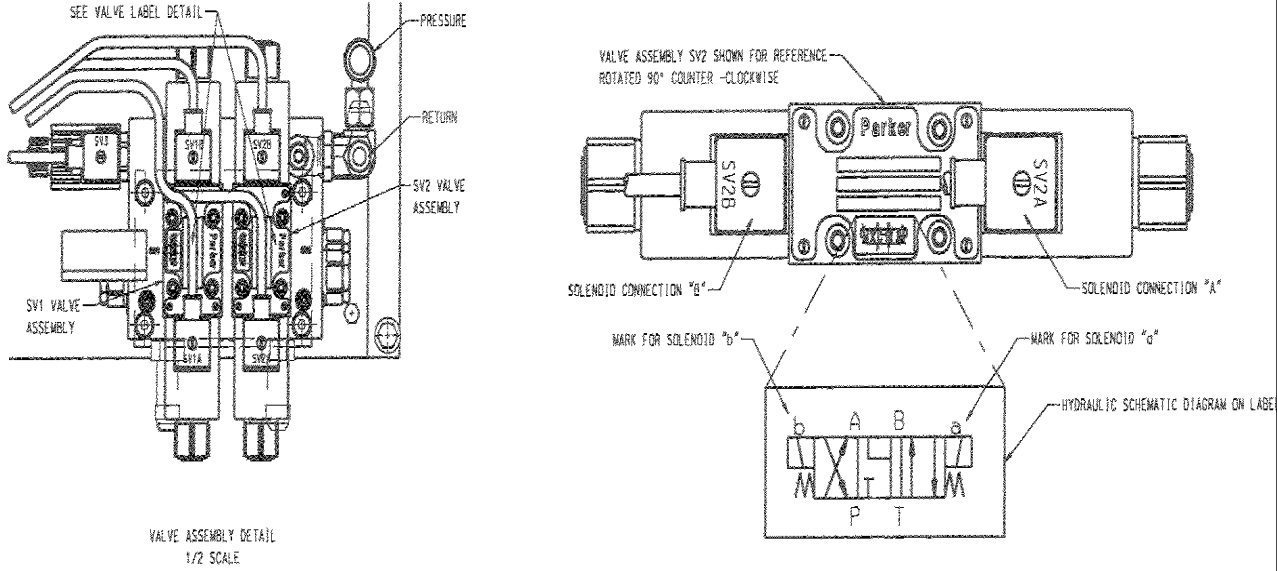

Figure 8b. Hydraulic Power Unit

Ordering Replacement Parts

Southworth has carefully chosen the components in your unit to be the best available for the purpose. Replacement parts should be identical to the original equipment. Southworth will not be responsible for equipment failures resulting from the use of incorrect replacement parts or from unauthorized modifications to the machine.

Southworth can supply all replacement parts for your Southworth lift. With your order, please include the model number and the serial number of the unit. You will find these numbers on the name plate.

To order replacement parts, please call the Parts Department at (207) 878-0700. Parts are shipped subject to the following terms:

- FOB factory.
- Returns only with the approval of our parts department.
- Payment net 30 days (except parts covered by warranty).
- Freight collect (except parts covered by warranty).

Parts replaced under warranty are on a “charge-credit” basis. We will invoice you when we ship the replacement part, then credit you when you return the assumed substandard part.

Parts Department
Southworth Products Corp
P.O. Box 1380
Portland, ME 04104-1380
Telephone: (207) 878-0700
FAX: (207) 797-4734
repairparts@SouthworthProducts.com

Warranty

Southworth Products Corp. warrants this product to be free from defects in material or workmanship for a **period of one (1) year** from date of shipment, providing claim is made in writing within said year. This warranty shall not cover failure or defective operation caused by misuse, misapplication, negligence or accident, exceeding recommended capacities, or altering or repairing, unless alteration is authorized by Southworth Products Corp. Except as set forth herein, there are no other warranties, express or implied, including the warranties of merchantability and fitness for a particular purpose, all of which are hereby excluded.

Southworth Products Corp. makes no warranty or representation with respect to the compliance of any product with state or local safety or product standard codes, and any failure to comply with such codes shall not be considered a defect of material or workmanship under this warranty. Southworth Products Corp. shall not be liable for any direct or consequential damages arising out of such non-compliance.

Southworth Products Corp.'s obligation under this warranty is **limited** to the replacement or repair of defective components at its factory or another location at Southworth Products Corp.'s discretion. This is buyer's sole remedy. Except as stated herein, Southworth Products Corp. will not be liable for any loss, injury, or damage to persons or property, nor for direct, indirect, or consequential damage of any kind resulting from failure or defective operation of said material or equipment.

This warranty may be altered only in writing by Southworth Products Corp., Portland, Maine.

Southworth Products Corp. is widely acknowledged as the leading maker of hydraulic lifts and materials-handling equipment. Southworth machines are rugged and reliable, and are designed to provide years of trouble-free service. The designs are based on extensive engineering experience. These are good reasons for specifying Southworth machines in your plant.



SOUTHWORTH

SOUTHWORTH PRODUCTS CORP
P.O. Box 1380, Portland, ME 04104-1380
Telephone: 800-743-1000 • 207-878-0700
Fax: 207-797-4734