

Owner's Manual

SOUTHWORTH

Dura-Dock Dock Lift Series



Model # _____

Serial # _____

Date placed in Service _____

SOUTHWORTH PRODUCTS CORP
P.O. Box 1380 • Portland, ME 04104-1380
Telephone: (207) 878-0700 or (800) 743-1000
Fax: (207) 797-4734
www.SouthworthProducts.com
Email: service@SouthworthProducts.com

October 2011

Please note: This manual was current at the time of printing.
To obtain the latest, most updated version, please contact
Southworth's Customer Service Department or go to our website:
www.SouthworthProducts.com, under Parts & Service
you will find a complete list of current
owner's manuals to print.

Contents

INTRODUCTION	1
SAFE SERVICING OF THE LIFT	2
SAFETY	3
INSTALLATION INSTRUCTIONS	3
Preparation	3
Positioning the Lift	6
Hydraulic Connections	6
Electrical Connections	7
Testing	7
Completing Installation	7
OPERATING INSTRUCTIONS	8
Operating Procedure	8
MAINTENANCE	11
Hazards	11
Routine Periodic Maintenance	11
TROUBLESHOOTING	12
Troubleshooting Check List	12
Repacking Cylinders	14
Replacing Leg Rollers	16
Ordering Replacement Parts	16
Electrical Connections for Single-Phase AC	18
Electrical Connections for Three-Phase AC	19
WARRANTY	22

List of Figures

Fig. 1 Safe Servicing of Lift	2
Fig. 2 Mount the Lift Securely	3
Fig. 3 Typical Pit Installation.....	4
Fig. 4 Typical Pad Installation	5
Fig. 5 Using Lifting Eyes	6
Fig. 6 Hose Specifications.....	6
Fig. 7 Center the Load	8
Fig. 8 Secure the Load	8
Fig. 9 Pinch Points	9
Fig. 10 Labels and Precautionary Markings	10
Fig. 11 J-Style Cylinder	14
Fig. 12 Parts Identification	15
Fig. 13 Standard 3.2 HP Power Unit	17
Fig. 14 Hydraulic Pump and Down Valve	17
Fig. 15 Electrical Connections, Lifts Wired for Single-Phase AC	18
Fig. 16 Wiring Diagram, Lifts Wired for Single-Phase AC - without limitswitch	18
Fig. 17	19
Electrical Connections, Lifts Wired for Single-Phase AC - with limitswitch	19
Fig. 18 Schematic, Lifts Wired for Three-Phase AC	20
Table 1 Electrical Interface, Supplied by Customer....	20
Table 2 Hydraulic Oil Specifications	20

INTRODUCTION

The basic Dock Lift series lift may be modified in many ways to meet special requirements for load capacity, vertical travel, table size, power source, and other characteristics. Dock Lifts can also be fitted with many optional accessories and modifications to suit the customer's needs.

This manual contains information to acquaint you with the safe and proper installation, use, and upkeep of an Dock Lift series dock lift. You should ensure that this manual is available to personnel working with and on the lift and require its use by these personnel.

Dock Lifts are designed for lifting and vertical positioning of equipment and materials in a wide variety of industrial settings. The instructions set forth in this manual are not necessarily all-inclusive, as Southworth cannot anticipate all conceivable or unique situations.

In the interest of safety, please read all of this manual carefully, and be familiar with its contents before you install, use, or service the Dock Lift. If you have any questions about any of the instructions in this manual, please contact your dealer or Southworth Products Corp.

Southworth's product warranty is shown on the back cover of this manual.

This instruction manual is **not intended to be or to create any other warranty, express or implied, including any implied warranty of merchantability or fitness for a particular purpose, all of which are hereby expressly excluded.**

As set forth more specifically in the product warranty, Southworth's obligation under that warranty is **limited** to the repair or replacement of defective components, which shall be the buyer's **sole remedy**, and Southworth shall not be liable for any loss, injury, or damage to persons or property, nor for any direct, indirect, or consequential damage of any kind resulting from the Dock Lift series lift.

SAFE SERVICING OF THE LIFT



WARNING !

Only authorized personnel should perform inspection or maintenance and service procedures. Unauthorized personnel attempting these procedures do so at the risk of severe injury or death.



DANGER !

Failure to properly adhere to lift blocking procedures is to risk the sudden and uncontrolled descent of the lift during maintenance or inspection. A falling lift can cause severe injury or death.

This procedure describes the only factory-approved method of working under a lift. Follow these instructions **EVERY** time you plan to reach or crawl beneath the lift to perform service or maintenance – no matter how momentary that might be.

If the factory-provided maintenance device is damaged or missing, stop immediately and consult the factory for assistance. The manufacturer is not liable for your failure to use the approved maintenance device(s) and procedures that have been provided.

1. Any load must be removed from the lift prior to engaging the maintenance device(s). These devices are designed to support an unloaded lift only. Failure to remove the load from the lift prior to blocking could cause the failure of the maintenance device(s) and allow the lift to fall unexpectedly. This can result in personal injury or death, or permanent damage to the maintenance device(s) and/or the lift.
2. Raise the lift to its fully raised position. If you do not, the maintenance device(s) may not be able to be placed properly in its/their designed blocking position.
3. Remove the maintenance device(s) from its/their storage location and place it/them into the engaged position as shown in Figure 1. (Note: further information may be useful here to provide additional instructions as to the location and method of storage and engaged positions).
4. Lower the lift until it makes complete contact with the maintenance device(s). Re-check to ensure that all provided devices are fully and securely engaged. If the device(s) is/are not fully engaged the lift could fall unexpectedly, resulting in permanent damage to the device(s) or the lift.



DANGER !

If for any reason you are unable to lower the lift completely onto the maintenance device(s), stop immediately and consult the factory. Failure to properly use the factory approved maintenance device(s) could result in severe injury or death.

5. (For single-acting hydraulic, and pneumatic lifts) Once the maintenance device(s) is/are properly and securely engaged, continue to press the down button, valve or switch for an additional 5-10 seconds to

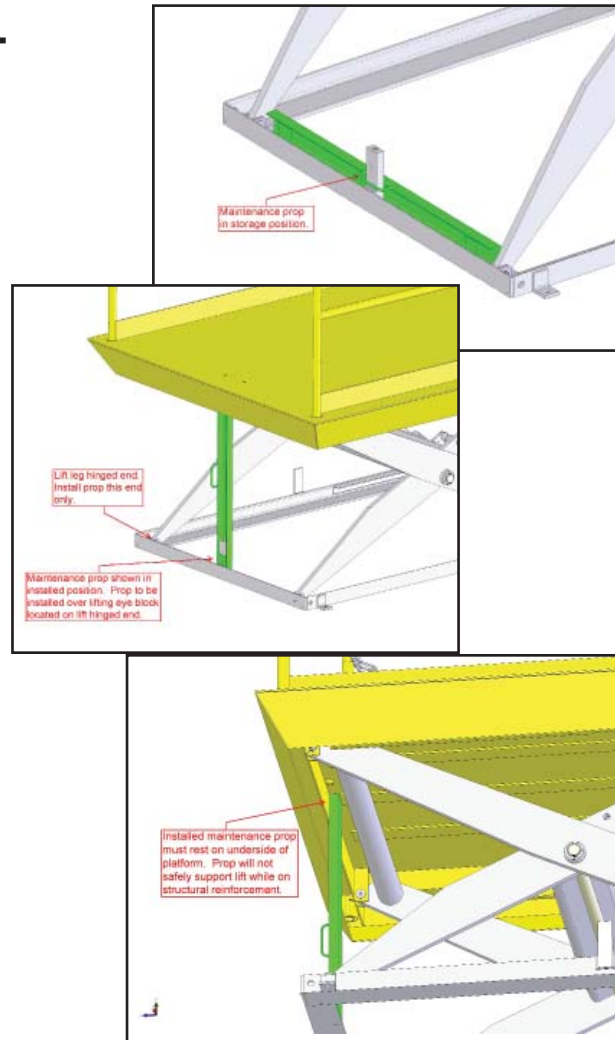

Figure 1 – Safe Servicing of Lift

relieve all pressure in the operating system (add more specifics here as required for pneumatic lifts).



WARNING !

Failure to relieve operating system pressure could result in the sudden and unexpected release of high pressure fluids (or air) during maintenance and/or repair of the lift and result in severe injury or death.

6. Follow OSHA electrical lock-out/tag-out procedures. Disconnect and tag all electrical and/or other power sources to prevent an unplanned or unexpected actuation of the lift.
7. Once inspection or work is complete, reverse the performance of the steps above to raise the lift off the maintenance device(s) and place the device(s) back into its/their designated storage position(s).



DANGER !

HIGH VOLTAGE ! – Disconnect and/or lock out the electrical supply to the power unit prior to any installation or maintenance being performed.

SAFETY

The safety of all persons operating, maintaining, repairing, or in the vicinity of the Dock Lift is of paramount concern to Southworth. The dock lift is a powerful machine with moving parts, and is **capable of causing personal injury if proper precautions are not taken.**

Therefore, throughout this manual, Southworth has identified certain hazards which may occur in the use of the dock lift, and provided appropriate **instructions** or **precautions** which should be taken to avoid these hazards.

In some cases, Southworth has also pointed out the **consequences** which may occur if Southworth's instructions or precautions are not followed. Southworth uses the following system of identifying the severity of the hazards associated with its products:

“DANGER” - Immediate hazard which will result in severe personal injury or death.

“WARNING” - Hazard or unsafe practice which could result in severe personal injury or death.

“CAUTION” - Hazard or unsafe practice which could result in minor personal injury or property damage.

Please read and follow this instruction manual, including all safety instructions and precautions, carefully and completely.

INSTALLATION INSTRUCTIONS

Preparation

Before you start to install the lift, check for local codes and ordinances which may apply. It is your responsibility to obtain any necessary permits.

Read all of these installation instructions carefully. Be sure to read and understand all of the warnings!

If your unit is designed to be installed in a pit, check the pit before you start to install the lift. Measure the length and width of the dock lift, then measure the pit, and be sure the pit allows adequate clearance. Does the pit have 90° angles at each corner? To check, measure across the opposite corners of the pit. The measurement on each diagonal should be the same, within 1/2 inch. The walls of the pit should be vertical. Check with a carpenter's square.

If the power unit will be mounted away from the lift (“external power unit”), check the mounting arrangement for the power unit. The power unit should be sheltered from the weather. It should be mounted within 30 feet of the lift to minimize the pressure drop in the hydraulic system. Be sure the hydraulic lines have been installed properly.

Note: Dock Lifts, require handrails. Throughout this manual, the handrails have been omitted for clarity.

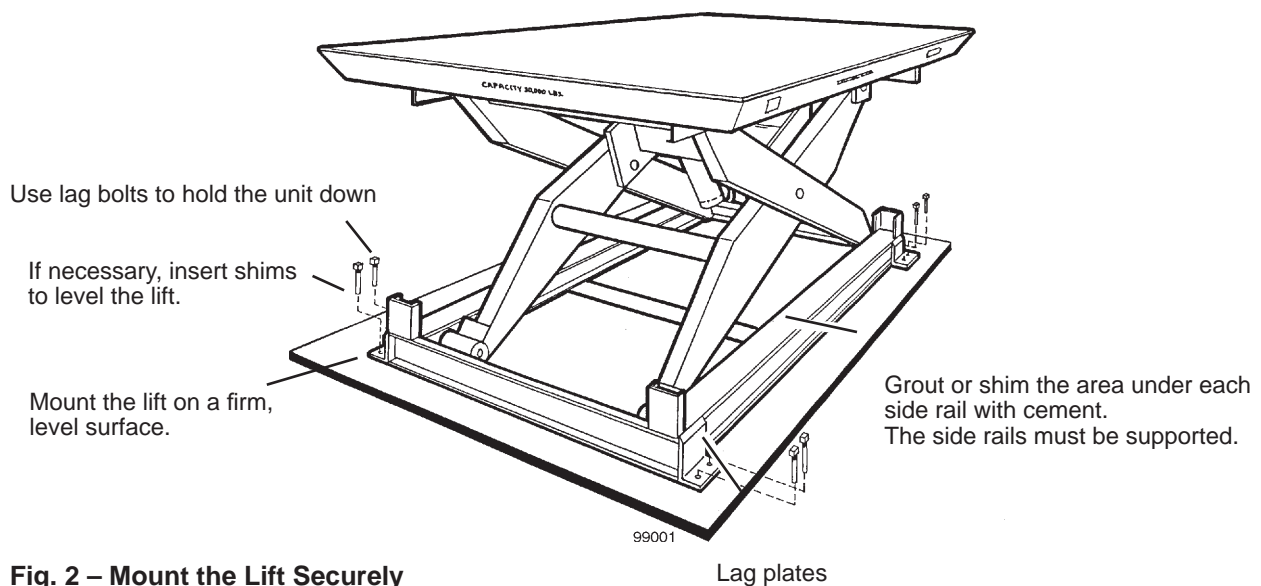

Fig. 2 – Mount the Lift Securely

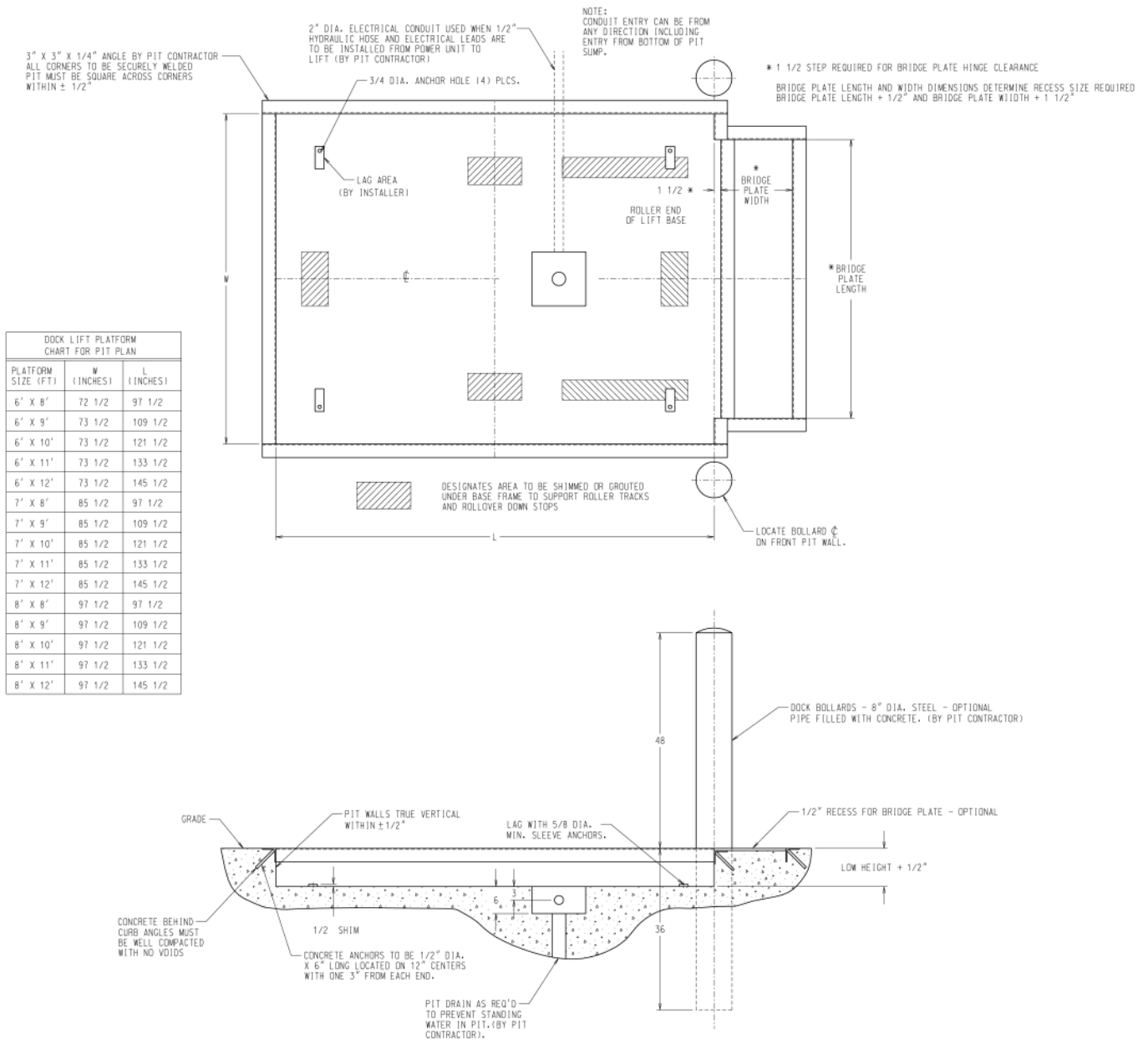
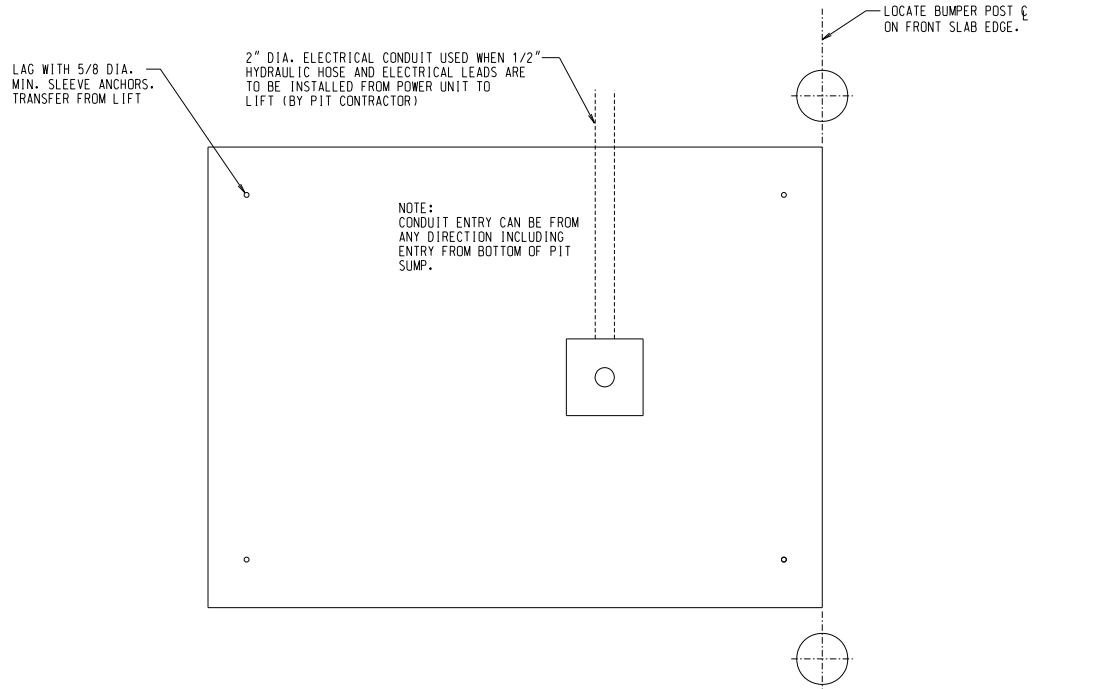
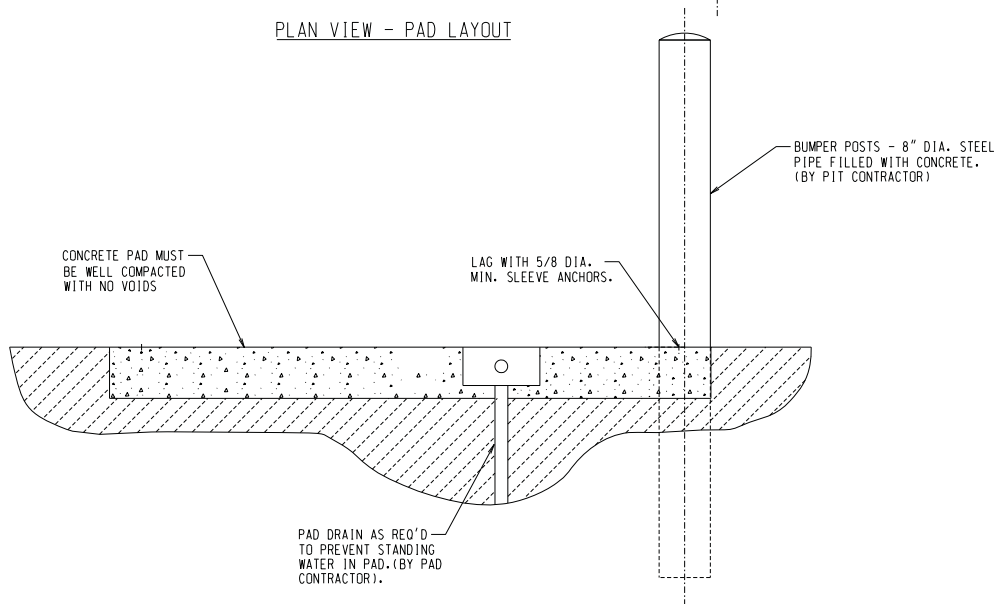

Fig. 3 – Typical Pit Installation

TYPICAL PAD INSTALLATION



PLAN VIEW - PAD LAYOUT



SIDE VIEW - PAD LAYOUT

Fig. 4 - Typical Pad Installation

Fig. 5 – Using Lifting Eyes

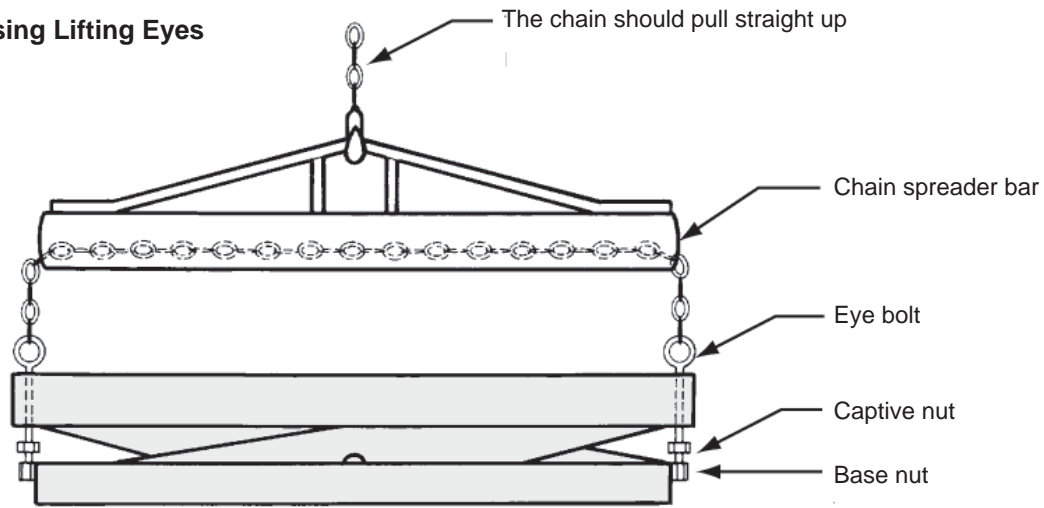

WARNING!

Protect the power unit from rain or moisture. If the electrical parts in the power unit get wet, workers may be hurt by electrical shock. The electrical parts may fail if they are wet.

WARNING!

The electric motor in the lift can create sparks. Don't install the power unit in an area where flammable gases may be present.

- A crane or lift truck that can lift the unit safely.
- Shims and lag bolts – see the pit plan if the lift will be mounted in a pit.
- A masonry drill and bit to drill the holes for the lag bolts.
- A power supply with the specified voltage, including fuses or circuit breakers as specified in Figures 12, 13 and 14.

If the power unit will be mounted away from the lift ("external power unit"), you will also need:

- Extra hydraulic oil for flushing the underground lines and refilling the tank. See Table 2 for the oil specifications.

Positioning the Lift

Remove the shipping material and unskid the lift. On the front of this manual, confirm the model number, serial number, and date the lift is placed in service. You can find the model number and serial number on the name plate. The name plate is located on the crossbar at the base of the cylinders.

Move the lift into position, supporting the base of the lift. If the lift has a hinged throwover plate, set the lift in position so the plate is in the appropriate orientation. Install the lift as shown in Figure 2.

CAUTION!

Do not hang the lift from the table top. This can damage the lift.

WARNING!

If the lift is mounted on an unstable surface, it may tip over when it is in use. You may be hurt, and the lift and load may be damaged.

If your lift has lifting eyes, as shown in Figure 3, use these when you move the lift. It is best to use a chain spreader, so the chain sections pull straight up. (You must supply the chain and spreader.) If a chain spreader is not available, using a fork truck, place the forks on the dock lift platform then chain over the forks from lifting eye to lifting eye. Once the lift is in position remove both lifting eyes, and use one lifting eye screwed into the third hole on the platform to pull the lift up and set the maintenance device to finish installation connections.

Hydraulic Connections

Note: This lift is supplied with Conoco Ecoterra 32 hydraulic oil. Do not substitute.

Install the power unit. Install the hydraulic line between the power unit and the lift as shown on the pit plan.

Blow out the hydraulic line with compressed air before connecting it to the dock lift. Replace the solid plug on the hydraulic fluid tank with the vented plug supplied.

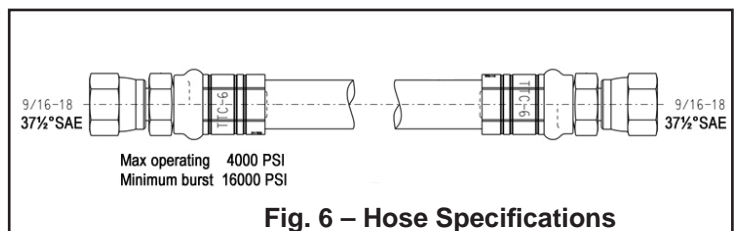

Fig. 6 – Hose Specifications

WARNING!

Be sure that the hydraulic line will not be pinched by the lift as it raises or lowers. If you allow the line to be pinched, the lift may not work properly. A hose may break, the dock lift may drop suddenly, and someone may be hurt.

CAUTION!

It is very important to keep the hydraulic oil free of dirt, dust, metal chips, water, and other contamination. Most of the problems with hydraulic systems are caused by contamination in the oil. Be sure to flush all hydraulic lines before connecting remote power units.

CAUTION!

If you do not install the vented plug in the tank, the pump may be damaged.

Electrical Connections**DANGER!**

The lift may use a power supply of up to 575 Volts AC. This voltage can kill you. Do not work with the electrical parts unless you are a qualified electrician.

Make temporary electrical connections to the lift, as shown in Figure 13 through 15. This temporary set-up will allow you to raise the lift.

WARNING!

The fusing requirements are shown in Table 1. To avoid fire danger, follow these requirements.

On a lift designed for three-phase AC, you must be sure the pump motor is turning in the right direction. The dock lift should start to move quickly when you press the “up” or “down” button. If the dock lift does not move in 2 or 3 seconds, do not try to operate the lift! Exchange any two of the three-phase leads. If this does not correct the problem, see the troubleshooting instructions at the end of this manual.

CAUTION!

If you have a unit designed for three-phase AC and you connect the power so the motor runs backwards, the lift will not operate, and you may damage the pump. Do not operate the lift for more than 2 or 3 seconds if you think the motor might be turning backwards.

Raise and chock the lift, as shown in Figure 1.

Make the permanent electrical connections as shown

in Figure 13 through 15.

Check the level of the hydraulic fluid. On most models, when the lift is fully elevated, the oil should be about 3/4 inch above the bottom of the tank. Use a dipstick to check the oil level, and add oil as necessary.

Testing

Clear the area around the lift. Remove any loose wires, lumber, or other materials which might get in the way of the lift as it raises or lowers.

Remove the maintenance chocks and warn others to stay away from the lift. Operate the lift through its full range of travel. The lift should rise smoothly with a quiet humming sound, and lower smoothly and quietly. Raise and lower the lift a few times to check the clearances around the dock lift.

WARNING!

As the dock lift moves up and down, “pinch points” are created at the places shown in Figure 6. If you are standing too close to the lift when it is moving, your arm or leg may be caught in the moving parts, and you may be hurt. Stay away from the pinch points when the lift is moving.

Completing Installation

If your lift is mounted in a pit, align the unit with the sides of the pit. Once you are sure the lift is positioned correctly, mark the locations of the lag holes in the base frame, and drill the holes. If necessary, insert metal shims to level the base of the lift. Insert and tighten the lag bolts to secure the lift. Grout under the base rails to prevent vibration and distortion of the base frame, as shown in Figure 2.

If the lift is lowering too quickly or too slowly, you can change the “down speed” by adjusting the flow control. The flow control may be mounted either internally, at the base of the cylinders, or on the external power unit.

WARNING!

When adjusting the flow control, always raise the dock lift and insert the maintenance chocks, as shown in Figure 1. Do not try to adjust the flow control while pressing the “down” button. If you try this, the dock lift may drop suddenly, and you may be hurt.

It is important that you follow these steps when adjusting the flow control:

- **Raise the dock lift and insert the maintenance**

chocks, as shown in Figure 1.

- If you want the lift to lower more slowly, turn the control clockwise up to 1/4 turn at a time. If you want the lift to lower more quickly, turn the control counterclockwise up to 1/4 turn. Don't move the control more than 1/4 turn at a time.
- Remove the maintenance chocks, and check the descent speed.
- Every time you want to change the adjustment again, raise the table again and insert the maintenance chocks as shown in Figure 1.

Test the lift with the rated load. If the lift does not rise, and you hear a loud squealing noise, the pressure relief valve is operating. Contact Southworth for instructions.

WARNING!

Don't continue to use the lift if this happens. The pump will overheat very quickly, and may be permanently damaged. Do not try to adjust the relief valve. If you change the setting on the relief valve, you may overwork the lift. This can cause the lift to fail suddenly, and you may be hurt.

As a final step, clean up all spilled hydraulic fluid. Spilled hydraulic oil is slippery, and may present a fire hazard.

OPERATING

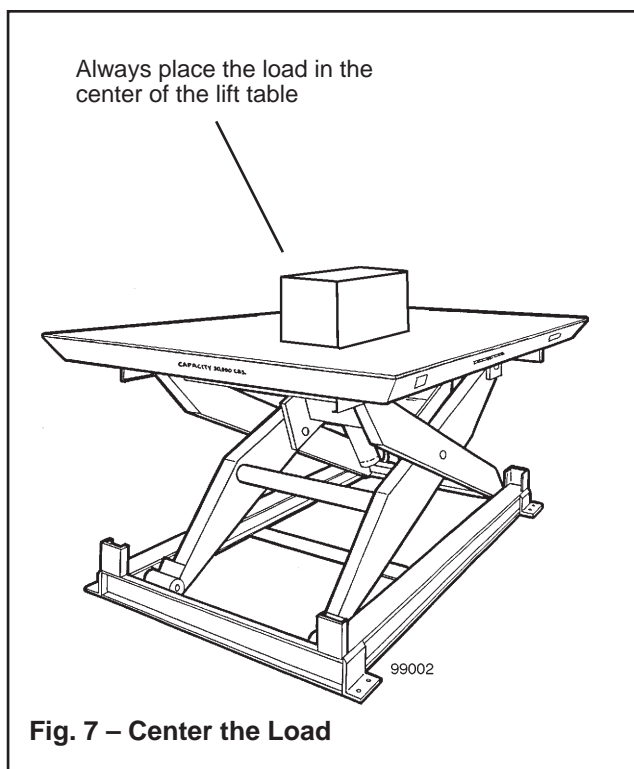

INSTRUCTIONS

Operating Procedure

Before operating the lift, read and understand this entire section.

DANGER!

The lift may use a power supply of up to 575 Volts AC. This voltage can kill. Do not work with the electrical parts unless you are a qualified electrician!

Locate the lift on a firm, flat surface as shown in Figure 2. Stationary lifts should be lagged to the floor.

WARNING!

If you place the lift on a soft surface, it may tip over, especially when it is loaded or raised. Someone may be hurt, and the lift and load may be damaged.

Load the lift correctly.

- Be sure that the load weighs no more than the maximum rated for the lift. The maximum rated load is shown on the platform skirt.

WARNING!

Do not try to lift a load that exceeds the maximum rating. If you try this, the lift may fail suddenly. Someone may be hurt, and the lift and load may be damaged.

- Place the load in the center of the dock lift, as shown in Figure 4.
- Do not try to load the lift while the dock lift is

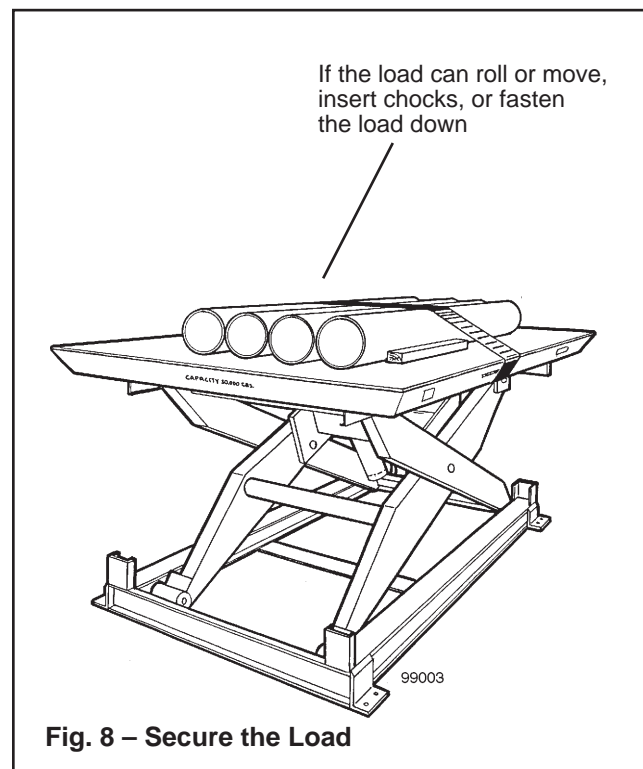



Fig. 9 – Pinch Points

moving.

- If you are lifting pipes or other objects which may be able to roll or move, fasten them down, or chock them as shown in Figure 5.

Be sure all workers are clear of the lift. Remove any lumber or other material which may fall onto the lift.

WARNING!

Do not use the unit to lift people unless it has been specially equipped for this purpose. A specially equipped lift will include operator protection, and an excess flow protector to keep the lift from dropping suddenly if a hydraulic line is damaged. Retrofit kits are available if you want to add these features to your lift.

WARNING!

As the dock lift moves up and down, “pinch points” are created as shown in Figure 6. Stay away from these pinch points! Part of your body or clothing may become caught, and you may be hurt.

Operate the lift. Press and hold the “up” button to raise the lift, and “down” to lower it. Release the button when

the lift reaches the limit of travel. If the lift does not operate within 2 or 3 seconds, turn off the lift and call a qualified maintenance worker.

WARNING!

If you hear a squealing noise from the pump, the pressure relief valve is operating. Do not continue to use the lift! The pump will overheat very quickly, and may be permanently damaged. The relief valve is included to protect the machine operators – don’t change the relief pressure setting.

Wait until the dock lift has stopped. Unload the lift.

WARNING!

The warning labels on the lift are there for your safety. If you find that the labels are worn or missing, or have been painted over, ask Maintenance to replace the labels before you use the lift. The labels are shown in Figure 7.

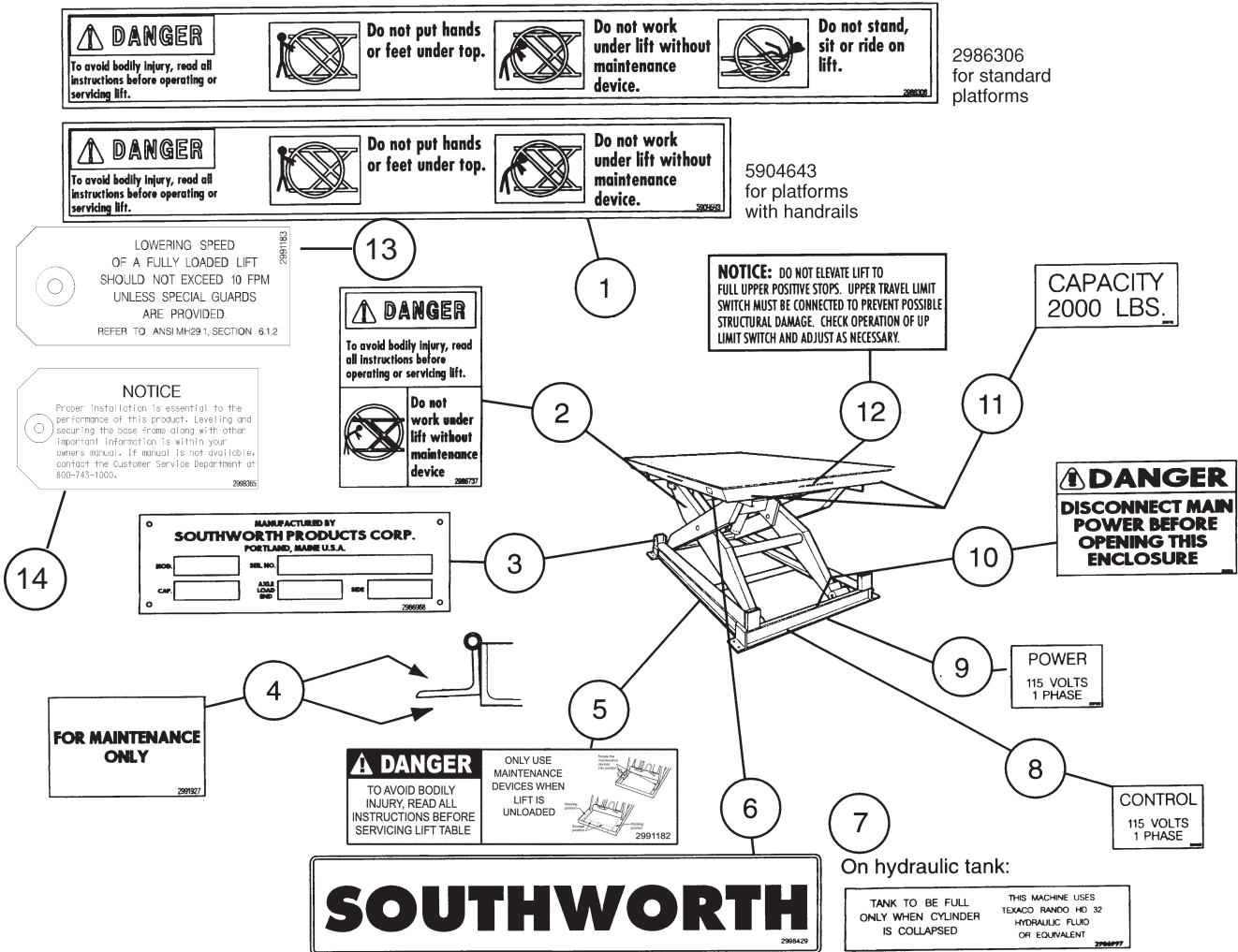

Item	Part#	Location
1.....	2986306	On both sides of platform (use for standard platforms)
	5904643	On both sides of platform (use for platforms with handrails)
2.....	2986737	On upper strongback
3.....	2986968	On lower strongback
4.....	2991927	On both sides of maintenance chocks, both sides of base
5.....	2991182	On both sides of base, as close to maintenance chock as possible
6.....	2998429	On both sides of platform
7.....	2986997	On hydraulic tank (not shown)
8.....	Control decals: 2986999 (115/1/60) 2986998 (24/1/60) 5900167 (110/1/50) 5900166 (24 VDC) On base end plate, where wire exits the base	
Item	Part#	Location

9.....	Power decals: 2987000 (115/1/60) 2991783 (12VDC) 5900160 (230/1/60) 5900161 (24VDC) 2987001 (208/3/60) 5900163 (110/1/50) 2987002 (230/3/60) 5900164 (220/1/50) 2987003 (460/3/60) 2999416 (380/3/50) 5900162 (575/3/60) 5900165 (415/3/50) On base end plate, where wire exits the base	
10.....	2986738	On junction box cover (alt: base end plate)
11.....	Capacity decals: 2998433 (500#) 2998437 (3500#) 2998425 (1000#) 2998426 (4000#) 2998434 (1500#) 2998442 (5000#) 2998427 (2000#) 2998428 (6000#) 2998435 (2500#) 5900159 (Other) 2998436 (3000#) On platform ends, two per end.	
12.....	2921026	On both ends of table top
13.....		Fasten to flow control (not shown)
14.....		Fasten to flow control (not shown)

Fig. 10 – Labels and Precautionary Markings

IMPORTANT: Please contact our Service Dept. at 800-743-1000 with any questions regarding the proper placement of labels.

MAINTENANCE

All servicing should be done by qualified personnel. Qualified personnel should be able to read and understand wiring and hydraulic diagrams. They should be able to troubleshoot live electrical circuits safely and in accordance with accepted practice. **For safety's sake**, if in doubt, please contact your dealer or Southworth Products Corp Service Department at (207) 878-0700 or (800) 743-1000.

Before servicing the lift, read and understand this entire section and the section entitled "Operating Instructions."

Hazards

There are several hazards you should be aware of as you service the lift:

DANGER!

The lift may use a power supply of up to 575 Volts AC. This voltage can kill. Do not work with the electrical parts unless you are a qualified electrician!

WARNINGS!

- As the lift moves up and down, "pinch points" are formed as shown in Figure 6. Keep hands, feet, and loose clothing away from these pinch points. If your hand or arm or a part of your clothing is caught, you may be hurt.
- A falling lift can cause severe personal injury. Before working under the lift, raise the lift and insert the maintenance chocks, as shown in Figure 1. Do this every time you work under the lift!
- Do not change the setting on the relief valve. If you do change the setting, this may cause a hydraulic part to fail. The hydraulic components in the lift are designed to handle a certain amount of pressure. If the relief valve does not open, this pressure may be exceeded. The lift may drop suddenly. Someone may be hurt, and the lift and load may be damaged.
- Release of fluids under high pressure can cause personal injury. Before you open any part of the hydraulic system, be sure to release the hydraulic pressure.
- The warning labels on the lift are there for the safety of the operators. See Figure 7.
- If the labels are worn or missing, or have been painted over, replace them before releasing the lift for operation.

Routine Periodic Maintenance

Every month:

Visually inspect the leg rollers, center pivot bushings and pins, cylinder clevis pins and bushings, and the leg hinge pins and bushings for signs of wear. Contact Southworth for instructions for repair of the center pivot pins and bushings.

WARNING!

If you are going to repair the center pivot pins and bushings, you must support the dock lift in a special way. Each set of leg plates, on both sides of the unit, must be clamped together firmly, using large C-clamps. You cannot use the chocks shown in Figure 1. With the pivot pins removed, they will not support the table top. If you do not support the dock lift correctly, the top may drop suddenly when you remove the pivot pins. Please contact Southworth for instructions.

Apply oil or WD-40 to the parts listed in the last step.

NOTE: Although the bearings are "lifetime lubricated" their performance may be extended by additional periodic lubrication.

Check the level and appearance of the hydraulic fluid. First, **raise the lift and insert the maintenance chocks, as shown in Figure 1.** On most models, when the lift is fully elevated, the oil should be about 3/4 inch above the bottom of the tank. Use a dipstick to check the oil level, and add oil as necessary. Change the oil if it has darkened, or feels gritty or sticky.

CAUTION!

It is important to use hydraulic fluid with the correct grade and properties. See the hydraulic oil specification in this manual, Table 2.

Every six months or 500 hours of operation, whichever comes first:

Raise the lift and insert the maintenance chocks, as shown in Figure 1.

Check all of the hydraulic fittings and hoses, and repair the connections as necessary. Occasionally the fittings can be worked loose by the vibrations from the power unit.

WARNING!

If a hydraulic fitting becomes loose, or if a hydraulic hose breaks, the hydraulic fluid may escape from the system under pressure. If the lift is raised when this happens, it can drop quickly. Someone may be hurt, or the lift or load may be damaged.

The clear plastic vent line and the cylinder rod(s) should be free of hydraulic fluid. If you find much fluid in either place, the cylinder seals may be leaking. (It is also possible the tank may be overfilled.) See the section on "Repacking Southworth Cylinders."

Disassemble the down valve as shown in Figure 11. Blow the valve plunger clean with compressed air. Reassemble and reinstall.

Drain and discard the hydraulic fluid. The suction filter is in the tank, at the point where the suction line runs out to the pump. Unscrew the hydraulic filter. Blow the filter clean. Reinstall the filter in the tank and reassemble the hydraulic line.

Refill the tank with new hydraulic fluid.

CAUTION!

If you continue to use fluid after it has "worn out," the moving parts in the system will wear more quickly.

Be sure all of the warning labels are in position and legible. The labels are shown in Figure 7. **The warning labels are intended to protect your workers.** If the labels are missing, or if they have been painted over, replace them.

TROUBLESHOOTING

PROBLEM	POSSIBLE CAUSE	CHECK THIS
Lift will not raise	Weight of load too heavy	Check the actual weight of the load
	Motor not running	Check the main disconnect switch, fuses, and wiring to the motor. A 20 amp, designated braker must be supplied for 110V
	Hydraulic oil level low	When lift is raised as far as possible, oil level should be 3/4" from bottom of tank. When lift is down, 3/4" from top
	Lift has reached its upper limit	Upper limit switch may need to be adjusted
	Motor may be "single phasing"	If motor hums but does not turn, check motor wiring and line fuses.
	Motor voltage too low	Supply voltage should be +/- 10% of the rating at the motor terminals.
	Tank vent plugged	If supplied, remove solid plug from tank, insert vent plug.
	Suction filter clogged	Clean suction filter as described in periodic maintenance
	Vacuum leak in suction line	Check all fittings in suction line
	Down valve may be energized	Check wiring to down valve, and solenoid in the valve
The lift fails to hold	Missing coupling	Check to insure the coupling has been installed between the pump and motor
	Down valve may be leaking	Remove down valve and inspect for debris which may be preventing it from closing.
	Down valve may be energized	Check the solenoid in the valve with a volt meter.
	Cylinder may be leaking	Check for oil leaking at top of 90° fitting.

Lift will not lower	Down valve may be de-energized	Check the solenoid in the valve with a volt meter
	Flow control needs adjustment	Adjust flow control as needed
Lift raises too slowly	Voltage may be low	Check voltage at motor to ensure proper voltage is being supplied
	Foreign material clogging suction filter, breather cap or pressure line	Remove necessary components and clean
	Pump may be overheating due to insufficient oil	Check oil level and oil viscosity
Lift lowers too slowly	Down valve may not be fully open or stuck closed	Remove down valve and clean
	Flow control may need adjustment	Adjust flow control as needed

If the steps listed above do not solve the problem, please call the Southworth's Customer Service Department

TROUBLESHOOTING WARNINGS

All servicing should be done by qualified personnel. Qualified personnel should be able to read and understand wiring and hydraulic diagrams. They should be able to troubleshoot live electrical circuits safely and in accordance with accepted practice. **For safety's sake**, if in doubt, please contact your dealer or Southworth Products Corp. Before servicing the lift, **read and understand this entire section and the section entitled "Operating Instructions."**

WARNING!

Before working underneath the lift, always raise the lift and insert the maintenance devices, as shown in Figure 1. Failure to do so may result in damage to the lift and severe personal injury!

CAUTION!

Do not continue to hold the "up" button for more than 2 or 3 seconds. You may damage the pump.

WARNING!

Do not change the relief valve setting. This valve has been included for the protection of workers who install, use, or service the lift. If it is ever necessary to repair or reset the valve, contact Southworth Products Corp. for instructions.

WARNING!

Do not disconnect the up limit switch. Instead, loosen the adjusting screw, and change the position of the arm. If you do disconnect the switch, when the lift platform moves up, it may not stop at the correct point. If the platform rises above the normal stopping point, the frame of the unit may be damaged. People working nearby may be hurt.

CAUTION!

If cavitation is allowed to continue, the pump may be damaged, and may have to be replaced.

WARNING!

Failure to insert the maintenance devices may result in damage to the lift and severe personal injury!

WARNING!

Failure to insert the maintenance devices may result in damage to the lift and severe personal injury!

DANGER!

Do not try to adjust the flow control while pressing the "down" button. If you try this, the lift table may drop suddenly, and you may be hurt.

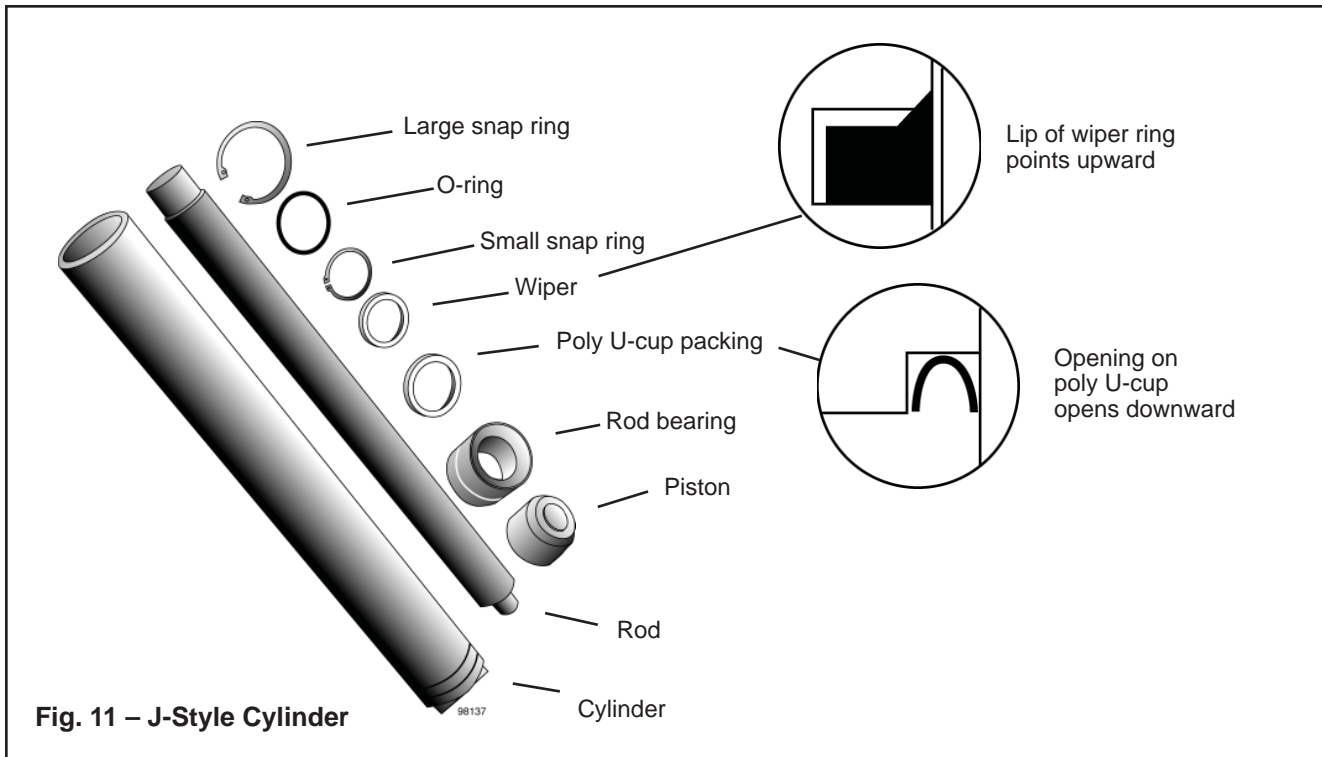

Fig. 11 – J-Style Cylinder

Repacking Cylinders

This section will tell you how to repack a “J-style” cylinder, shown in Figure 8. This type of cylinder is exclusive to Southworth, and repacking kits are only available through Southworth. To order a repacking kit, please call the Parts Department at (207) 878-0700 or (800) 743-1000. When ordering, specify the model number and serial number of the lift, and the cylinder number(s), as stamped on the base of the cylinder(s).

Before beginning this procedure, **read and understand this entire section.**

DL lifts usually have two or more cylinders. If the packing in one cylinder is worn, the packing should be replaced in all of the cylinders. This will prevent maintenance problems in the future. The repacking procedure is the same for each of the cylinders

WARNING!

Before working underneath the lift, always raise the lift and insert the maintenance chocks, as shown in Figure 1. Failure to do so may result in damage to the lift and severe personal injury!

Before you disassemble the old cylinder, be sure you have these items on hand:

- A repacking kit. Parts may be damaged when you disassemble the cylinder. You should have replacement parts on hand so you can reassemble the lift and use it immediately.

- A supply of new hydraulic oil. Contaminated oil may damage the new packing.
- A container to catch the used oil.
- A clean place to work. Choose a place which will not be damaged if you spill some oil.

Raise the lift and insert the maintenance chocks, as shown in Figure 1.

Turn off electrical power at the main disconnect or circuit breaker, or unplug the machine. This will prevent the lift from moving accidentally while you are working on it.

Disconnect the cylinder supply line at the pump, and place the end into a container to collect the used oil.

Disconnect the vent line(s) at the cylinder(s).

At the top end of the cylinder rod, remove the “keeper,” and drive out the clevis pin. Push the rod back into the cylinder to drive the hydraulic fluid out through the hose into the container. You may use air pressure at the vent hole to do this. Disconnect the hydraulic line(s) from the cylinder(s). Lift the cylinder(s) out of the lift. Be careful! Each cylinder is heavy!

Figure 8 shows the parts inside a J-style cylinder. At the upper end of the cylinder, remove the large snap ring. Pull the rod and piston all the way out of the cylinder. This assembly is heavy! Be careful not to drop it as it comes free.

Look for deformation around the hole at the clevis end of the cylinder rod. If necessary, clean up the rod diameter with a file to allow the rod bearing to slide off without damage.

Remove the plastic rod bearing from the cylinder rod. Observe how the wiper ring sits in the rod bearing. Remove the wiper ring and the O-ring from the rod bearing. Do not try to remove the aluminum piston from the cylinder rod, as this will damage the assembly. Loosen the small snap ring. Remove the poly U-cup from the piston.

Check the vent plug, and clean it if it appears dirty.

CAUTION!

While reassembling, it is very important to keep all of the parts free of dirt, dust, metal chips, water, and other contamination. Most of the problems with hydraulic systems are caused by contamination in the oil.

Clean the piston surfaces, and install a new fiber wear ring. Install a new poly U-cup seal, with the open part of the seal facing down.

Clean all of the surfaces on the rod bearing. Install a new O-ring and wiper. Replace the rod bearing assembly on the rod.

CAUTION!

Be careful not to install the wiper backwards. The lip on the wiper should point upwards, as shown in the detail in Figure 8.

Clean the bore of the cylinder tube thoroughly. Inspect the bore of the tube for scratches that run up and down, along the length of the cylinder. If you do see any scratches, hone the inner surface of the cylinder. Be sure to clean the tube thoroughly after you do this.

Lubricate the seal and piston with clean grease or oil. Carefully insert the piston and rod back into the cylinder. Be very careful not to pinch or tear the poly U-cup as the piston passes the shoulder inside the cylinder. It is helpful to tip the rod assembly and twist it as you slide it into the cylinder. Once the piston is inside the cylinder, it should slide easily.

CAUTION!

If the poly U-cup is pinched or torn during reassembly, the piston may not maintain pressure as designed.

Slide the rod bearing into the cylinder. Install a new snap ring to hold the rod bearing in place.

Install the cylinder(s) in the lift. Replace the clevis pin(s) and "keeper(s)." Reconnect all of the hydraulic lines and the vent line(s).

Fig. 12 – Parts Identification
(lift shown without precautionary labels for clarity)

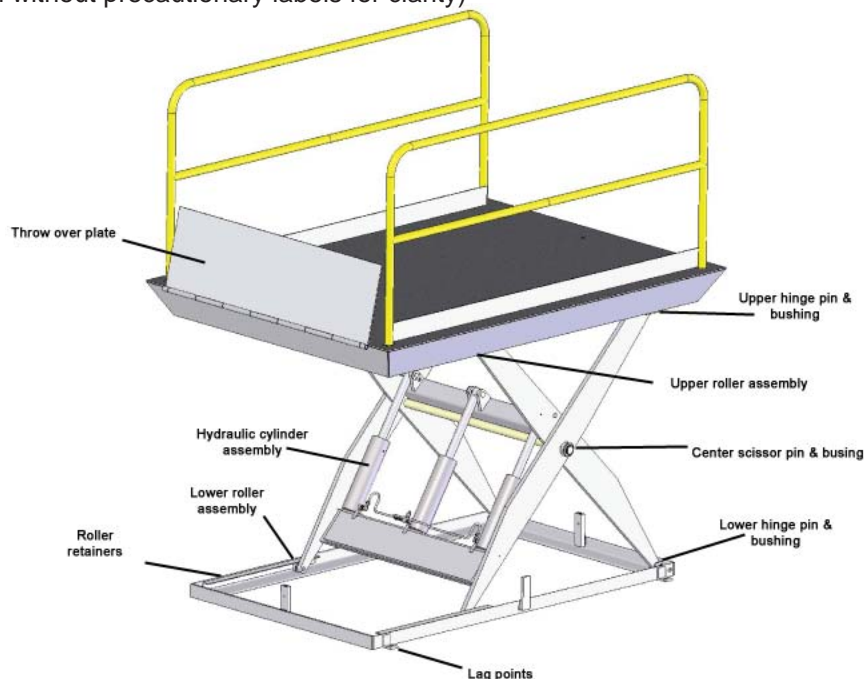

At the start of the packing process, you drained the cylinder(s) into a container. Replace this used oil with an equal amount of fresh oil. Be sure to reinstall the vent plug when you're done.

Turn on the electrical power and press the "up" button. The pump will self-prime. After a few seconds, the cylinder should lift the table off the maintenance chocks. Remove the maintenance chocks. Cycle the lift up and down a few times to remove air pockets. Check for leaks.

Raise the lift and check the oil level with a dipstick. The oil should be about 3/4 inch above the bottom of the tank.

If you have spilled any oil, clean it up.

DANGER!

Spilled hydraulic oil is slippery, and may present a fire hazard. Always clean up any spilled oil.

Replacing Leg Rollers

Please contact the Service Department at Southworth Products Corp for instructions for your model and application at (207) 878-0700 or (800) 743-1000.

Ordering Replacement Parts

Southworth has carefully chosen the components in your lift to be the best available for the purpose. Replacement parts should be identical to the original equipment. **Southworth will not be responsible for equipment failures resulting from the use of incorrect replacement parts or from unauthorized modifications of the machine.**

Southworth can supply all replacement parts for your Southworth lift. Key parts are identified in Figures 9 through 11. With your order, please include the model number and the serial number of the lift. You may find these numbers on the name plate, which is located on the crossbar at the base of the cylinder(s). When you are ordering parts for a cylinder, also include the cylinder number. This is stamped on the base of the cylinder housing.

To order replacement parts, please call the Parts Department at (207) 878-0700 or (800) 743-1000. Parts are shipped subject to the following terms:

- FOB factory
- Returns only with the approval of our Parts Department.
- Payment Net 30 days (except parts covered by warranty).
- Freight collect (except parts covered by warranty).

Parts replaced under warranty are on a "charge-credit" basis. We will invoice you when we ship the replacement part, then credit you when you return the worn or damaged part.

Parts Department
Southworth Products Corp
Telephone: (207) 878-0700 or (800) 743-1000
FAX: (207) 797-4734

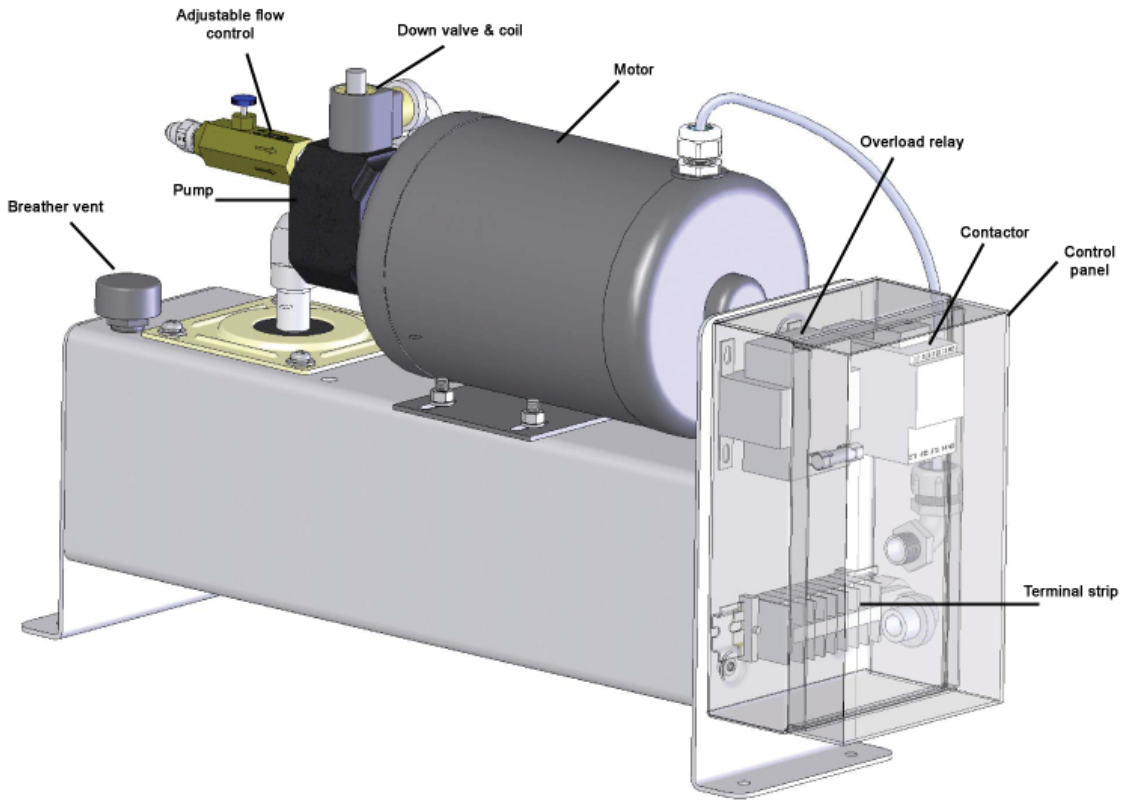

Fig. 13 – Standard 3.2 HP Power Unit

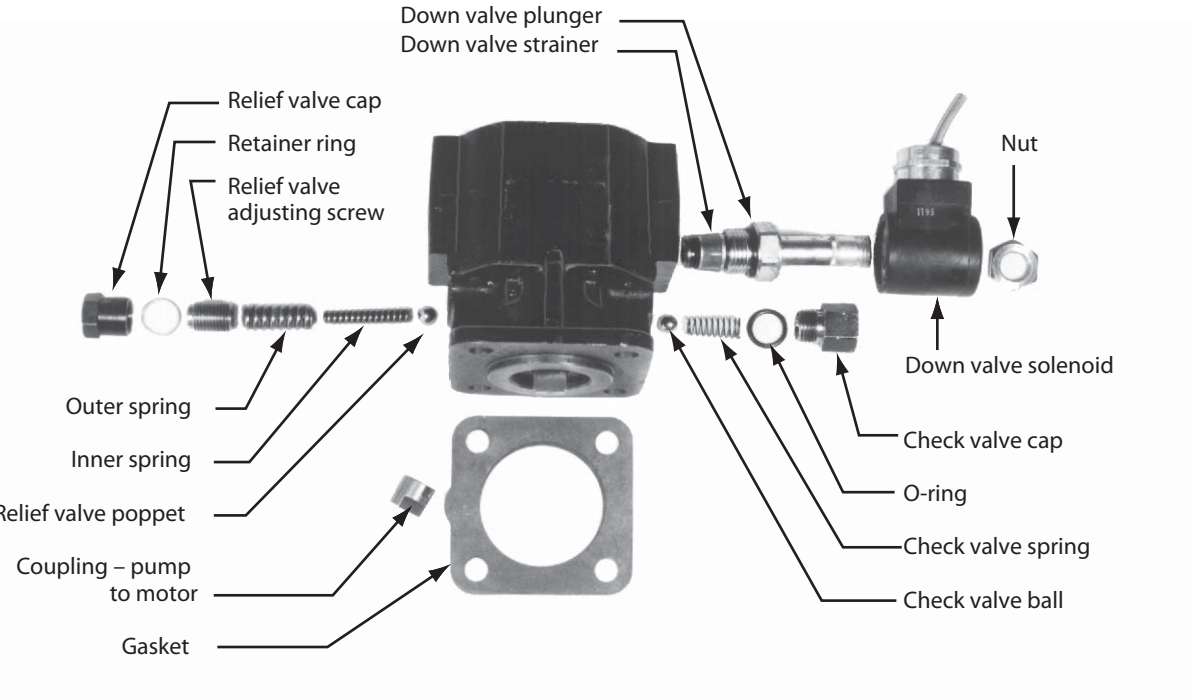

Fig. 14 – Hydraulic Pump and Down Valve

Electrical Connections for Three-Phase AC

208/230/460V-3PH60Hz
Supply voltage
(from fused disconnect)

Note: Ground connections not shown.
For ground connections use
supplied grounding terminal.

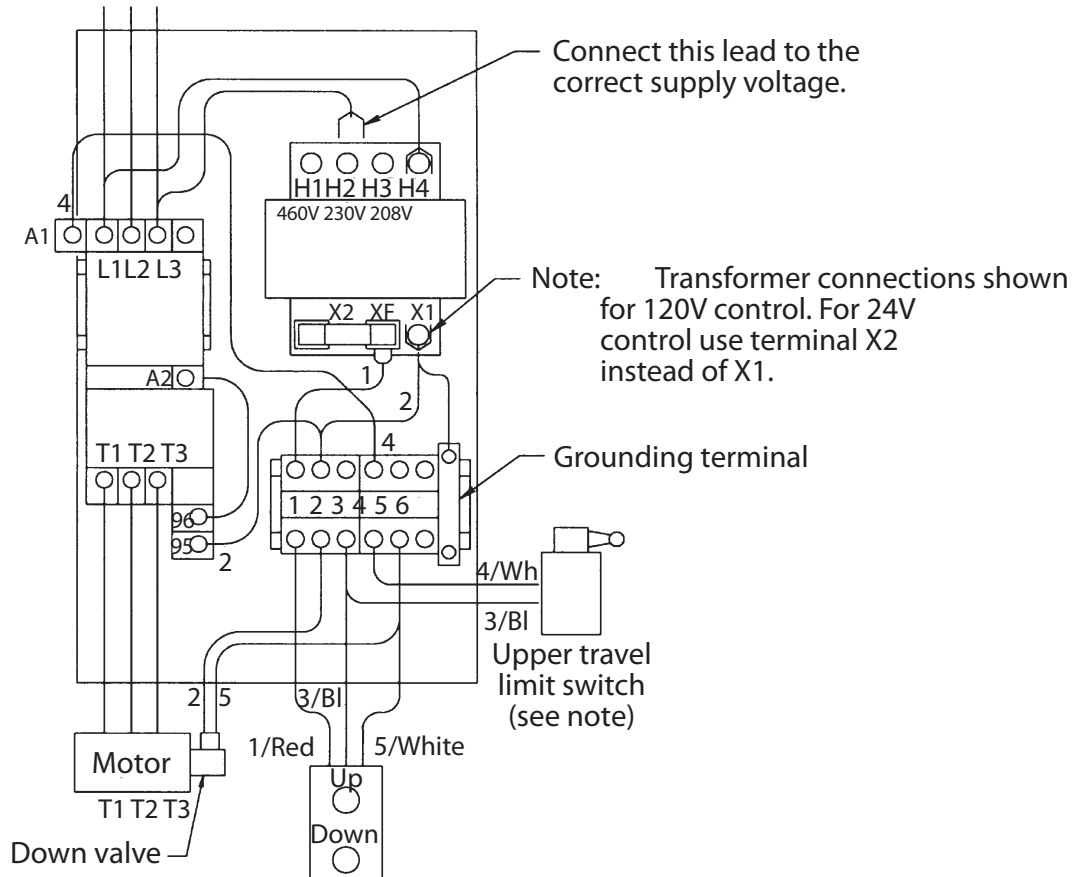

Fig. 17 – Electrical Connections, Lifts Wired for Three-Phase AC

Connect the power and control wiring to the proper terminals located in the control panel. The pump, motor and valve may be mounted on the lift unit itself (internal power unit) or in a separate location (external power unit). The control panel may be wall mounted.

CAUTION!

If on power-up the motor rotates in the wrong direction, don't continue to operate the lift. You may damage the pump. To correct the problem, interchange any two of the motor leads (T1, T2 or T3).

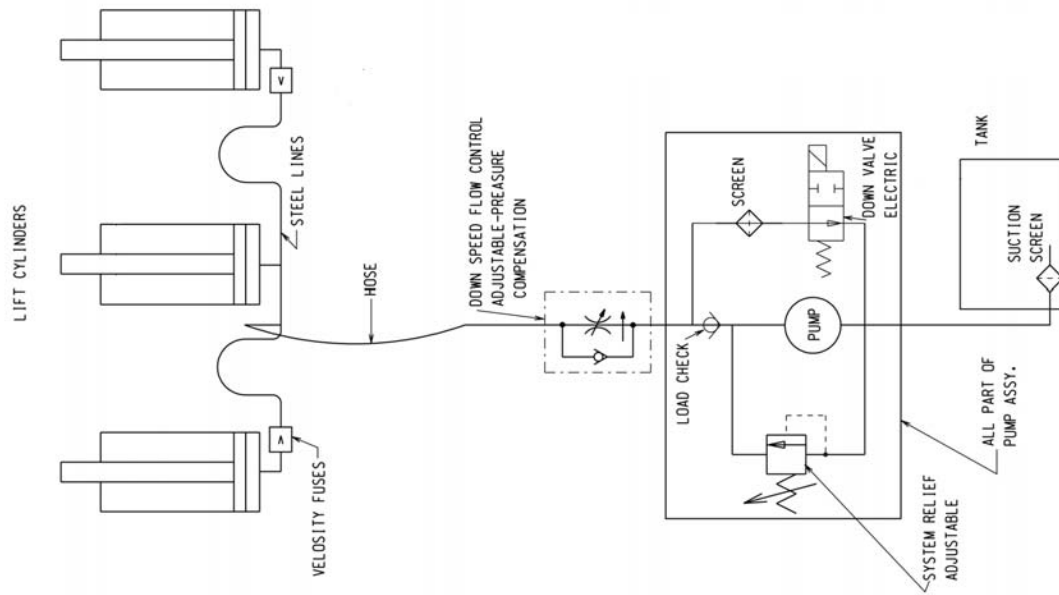

Fig. 18 – Hydraulic Diagram

Table 1 – Electrical Interface, Supplied by Customer

Motor Voltage	Required Fuse 1.0 HP Motor	Required Fuse 3.2 HP Motor	Required Fuse 5.0 HP Motor	Wire Gauge
120/1/60	20 AMP	—	—	12 AWG
208/1/60	20 AMP	—	—	12 AWG
230/1/60	20 AMP	—	—	12 AWG
208/3/60	10 AMP	12 AMP	20 AMP	14 AWG
230/3/60	10 AMP	12 AMP	20 AMP	14 AWG
460/3/60	5 AMP	6 AMP	10 AMP	14 AWG
575/3/60	5 AMP	5 AMP	7.5 AMP	14 AWG

Table 2 – Hydraulic Oil Specifications

If the lift will be used at normal ambient temperatures, Southworth supplies the unit with CONOCO Ecoterra 32 biodegradeable oil - do not substitute.

NOTICE

This lift is supplied with:
 Conoco Ecoterra[®] 32 Hydraulic Oil.
 Do not substitute.

Ecoterra Hydraulic oil is not compatible with oils containing Zinc. Mixing will result in poor machine performance, could damage hydraulic components, and will lessen the environmental benefits gained by using Ecoterra Hydraulic Oil.

Tank to be full only when cylinders are fully retracted.

CAUTION!

It is very important to keep the hydraulic oil free of dirt, dust, metal chips, water, and other contamination. Most of the problems with hydraulic systems are caused by contamination in the oil.

2 YEAR WARRANTY

Southworth Products Corp warrants this product to be free from defects in material or workmanship for a period of 2 years of single shift usage from date of shipment, providing claim is made in writing within that time period. This warranty shall not cover modified designs for special applications, failure or defective operation caused by misuse, misapplication, negligence or accident, exceeding recommended capacities, failure to perform required maintenance or altering or repairing, unless alteration is authorized by Southworth Products Corp. Except as set forth herein, there are no other warranties, express or implied, including the warranties of merchantability and fitness for a particular purpose, all of which are hereby excluded.

All batteries have a 90 day parts and labor warranty, this warranty covers any defects in material and workmanship from the date of shipment.

Southworth Products Corp also carries a 10 year structural warranty with this product line.

Southworth Products Corp makes no warranty or representation with respect to the compliance of any product with state or local safety or product standard codes, and any failure to comply with such codes shall not be considered a defect of material or workmanship under this warranty. Southworth Products Corp shall not be liable for any direct or consequential damages arising out of such noncompliance.

Southworth Products Corp's obligation under this warranty is limited to the replacement or repair of defective components at its factory or another location at Southworth Products Corp's discretion. This is buyer's sole remedy. Except as stated herein, Southworth Products Corp will not be liable for any loss, injury or damage to persons or property, nor for direct, indirect, or consequential damage of any kind, resulting from failure or defective operation of said product.

This warranty may be altered only in writing by Southworth Products Corp, Portland, Maine.

SOUTHWORTH

SOUTHWORTH PRODUCTS CORP

P.O. Box 1380, Portland, ME 04104-1380

Telephone: (800) 743-1000 • (207) 878-0700

Fax: (207) 797-4734

www.SouthworthProducts.com

SOUTHWORTH

We'll Show You How

Southworth is the world class supplier of products designed to improve productivity and enhance safety. Our staff has over 400 years of engineering experience. If one of our standard products does not meet your needs, our engineers can custom design equipment specifically suited to your material handling application.



Spring PalletPal Load Leveler



Lift with Flush Mount Turntable



Portable Container Tilters



Dock Lifts



Roll on Level Loaders



Portable Lifts



Stretchwrapping



Positioning

Floor to Mezzanine Lifts



Pallet Rotators



For more information, contact Southworth Products
Telephone (800) 743-1000 Fax (207) 797-4734
Email: salesinfo@SouthworthProducts.com