

Owner's Manual  
**The ELPH™**  
Elevating Powered Helper



Model# \_\_\_\_\_

Serial# \_\_\_\_\_

**For equipment manufactured after May 1999.**

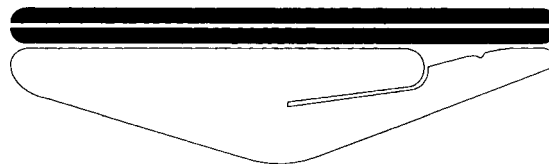

**SOUTHWORTH**

Southworth Products Corporation

P.O. Box 1380/Portland, Maine 04104-1380

Phone 800-743-1000 • FAX 207-797-4734

[www.southworthproducts.com](http://www.southworthproducts.com)  
[service@southworthproducts.com](mailto:service@southworthproducts.com)

January 2007

## INTRODUCTION

Southworth's Shop ELPH has been designed to take the effort out of lifting and carrying. The ELPH conforms to ergonomic guidelines in order to make them as comfortable and safe as possible. The battery that powers the platform is sealed for safety and can be recharged many times.

**This manual contains information to acquaint you with the safe, proper use and upkeep of the ELPH. You should ensure that this manual is available to personnel working with the ELPH.**

**In the interest of safety please read the entire manual carefully and be familiar with its contents before you use or service the ELPH. If you have any questions about any instructions in this manual, please contact your dealer or Southworth Products Corporation.**

The ELPH is fitted with an identification plate located on the central cross member at the base of the actuator. The identification plate is stamped with the model number, capacity and serial number; this information should be provided when seeking spare part inquiries or technical support.

## TABLE OF CONTENTS

INTRODUCTION .....	2
SAFETY .....	4
UNPACKING .....	5
Transit Damage .....	5
Hazardous Environments .....	5
High Cycle Applications .....	5
SPECIFICATIONS .....	5
PARTS BREAK DOWN .....	6
OPERATION .....	7
Platform Control .....	7
Caster Configuration .....	7
Brake .....	7
Direction Lock .....	7
Battery .....	7
BATTERY LIFE .....	8
CONTROL BOX .....	8
ACTUATOR .....	8
LOAD CAPACITY .....	8
MAINTENANCE .....	9
Monthly .....	9
Annually .....	10
TROUBLE SHOOTING .....	10
ORDERING REPLACEMENT PARTS .....	11
RETURN MATERIALS AUTHORIZATION (RMA) .....	12
WARRANTY .....	13

## LIST OF FIGURES

Fig 1	Shop ELPH .....	6
Fig 2	Pinch Points .....	7
Fig 3	Battery Pack & Control Box .....	8
Fig 4	Labels and Precautionary Markings .....	9

## SAFETY

The safety of all persons operating, maintaining, repairing, or in the vicinity of the ELPH is of paramount concern to Southworth. Therefore, throughout this manual, Southworth has identified certain hazards which may occur in the use of the ELPH and provided appropriate instructions or precautions which should be taken to avoid these hazards. In some cases, Southworth has also pointed out the consequences that may occur if these instructions or precautions are not followed. Southworth uses the following system of identifying the severity of the hazards associated with its products:

“DANGER”	Immediate hazard which will result in severe personal injury or death.
“WARNING”	Hazardous or unsafe practice which could result in severe personal injury or death.
“CAUTION”	Hazardous or unsafe practice which could result in minor personal injury or property damage.

Please read and follow the instructions in this manual, including all safety instructions and precautions, carefully and completely.

## UNPACKING AND SET-UP OF THE ELPH

- 1) Cut the banding straps and remove the ELPH from the box. (Make sure all of the parts are included before the box is discarded. Figure 1.)
- 2) Attach the handle to the ELPH by sliding the two threaded ends of the handle into the pockets that are welded to the base frame. Using the lock washers and the nuts, secure firmly.
- 3) Locate the battery control box assembly. Attach the assembly to the handle using the 4 self tapping screws, making sure the control box is to the right and the battery box is to the left. This allows the actuator to plug into the control box.
- 4) Make all the correct electrical connections (figure 3).

### TRANSIT DAMAGE

Inspect the ELPH for signs of damage in transit, paying particular attention to the electrical cabling. If there is evidence of damage, contact your Southworth dealer before using the ELPH.

### HAZARDOUS ENVIRONMENTS

The ELPH's electrical equipment is not suitable for use in flammable or explosive environments and must never be used when such hazards exist.

### HIGH CYCLE APPLICATIONS

The shop ELPH is designed for intermittent use. For high cycle operations, the following should be observed:

- 1) The ELPH is designed to achieve a minimum life of approximately 10,000 cycles. For intermittent use, this equates to many years of service.
- 2) The ELPH linear actuator should not exceed six (6) full cycles per hour. The recommended duty cycle for the actuator motor is 10%. This means that the motor should not be operated for more than 6 minutes of every hour.

## SPECIFICATIONS

	Model	
	DC3	DC5
<b>Capacity</b>	<b>300 lbs</b>	<b>500 lbs</b>
<b>Platform Size</b>	<b>19 5/8" x 31 1/2"</b>	<b>19 5/8" x 31 1/2"</b>
<b>Lowered Height</b>	<b>14 1/4"</b>	<b>14 1/4"</b>
<b>Raised Height</b>	<b>32 1/2"</b>	<b>32 1/2"</b>
<b>Vertical Travel</b>	<b>19"</b>	<b>19"</b>
<b>Weight</b>	<b>110 lbs</b>	<b>120 lbs</b>
<b>Dimensions (L x H x W)</b>	<b>38" x 37" x 19 5/8"</b>	<b>38" x 37" x 19 5/8"</b>
<b>Casters</b>	<b>5"</b>	<b>5"</b>
<b>Rise Time</b>	<b>36 Seconds</b>	<b>36 Seconds</b>

# PARTS BREAK DOWN

PARTS	DC-3	DC-5
	Part #	Part #
Platform & Frame	3060649	3060649
Directional Caster	5905969	5905969
Brake Caster	5905970	5905970
Front Caster	5905968	5905968
Battery Pack	5905918	5905918
Battery Mounting Bracket	5905920	5905920
Control Box	5904584	5905917
Hand Control	5905958	5905958
Actuator	5905959	5905916
Decal Kit	3055607	3055607

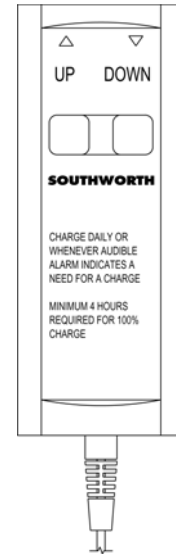

Hand Control

Figure 1 Shop ELPH



# OPERATING THE SHOP ELPH

## PLATFORM CONTROL

The position of the platform is controlled with a push button switch located on the hand control. The ELPH can be raised by pressing the UP button on the switch or lowered by pressing the DOWN button on the switch.

### WARNING!

As the ELPH platform moves up and down, "pinch points" are created where the scissor legs cross, where the legs meet the base and platform and in the path on which the rollers travel. When operating the ELPH, be careful to ensure that nobody becomes caught in the moving parts. (figure 2)

## CASTER CONFIGURATION

The ELPH is supplied with four swiveling casters. One of the rear casters is fitted with a brake and the other rear caster has a direction lock.

**Figure 2**  
**ELPH Pinch Points**

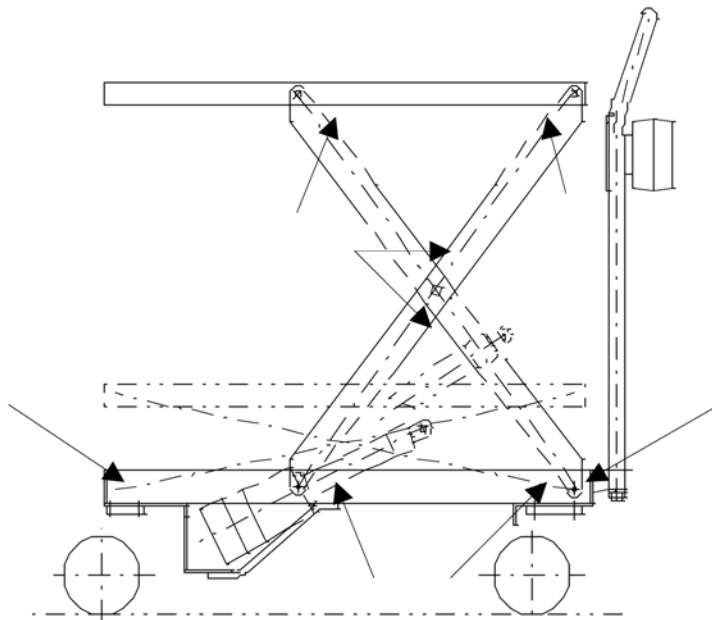

## BRAKE

The brake prevents the caster from both swiveling and rolling. Press the lever located on the top of the caster to engage the brake.

### CAUTION!

**The brake is an important safety device. Please ensure it is engaged when the ELPH is unattended. Attempt to find level ground whenever possible.**

## DIRECTION LOCK

The direction lock prevents the caster from swiveling but allows the caster to roll as usual. Use it when pushing the ELPH in a straight line to provide greater stability.

## BATTERY

The Shop ELPH is supplied with a 24 volt battery pack which snaps easily on to the control box. This allows for a quick exchange of battery packs if needed. The control box is mounted to the handle of the ELPH for easy access. The control box includes a quick disconnect hand control, and an internal charger.

### WARNING!

**The battery contains lead acid and should not be punctured or damaged. Seek urgent medical advice if acid contacts skin or clothing. Ensure that the battery is disposed of safely and according to local regulations.**

### WARNING!

**There is a ventilation hole in the back on the battery pack. This hole must remain clean and unblocked to ensure that positive pressure within the control box is released.**

### CAUTION!

**Because of the batteries self-discharge, over time you can not expect the battery to be fully charged. When you receive your ELPH it is recommended that you charge the battery immediately. The initial charge needs to be for a minimum of 24 to 48 hours. After this first initial charging, there is a maximum charging time of 6 hours to reach the batteries full charge capacity.**

## BATTERY LIFE

The life of the battery is determined on the amount of usage between charging. This is best explained as follows:

- 100% discharging depth: If the battery is totally discharged, there is approximately 180 charging cycles available.
- 50% discharging depth: If the battery is 50% discharged, there is approximately 400 charging cycles available.
- 30% discharging depth: If the battery is 30% discharged, there is approximately 1200 charging cycles available.

Therefore it is recommended to recharge the battery as frequently as possible. Doing this will ensure the longest battery life available.

## CONTROL BOX

Your control box is equipped with some special features. It has an internal charger with a 10 ft. charging cord, a soft start and stop function which eliminates jumping of the actuator and table. There is a unique acoustic alarm feature that tells you when the battery is at 50% capacity. The hand control, which is clearly marked with UP and DOWN buttons, comes with a 24" coil cord.

## ACTUATOR

The shop ELPH's actuator is one of its best features. You can hardly tell it's running because of its low noise level that's below 45db. It has built-in end-stop switches for protection against dead heading or damaging the actuator. The operating mechanism is a simple screw jack that's driven by an internal DC motor.

## LABELS AND PRECAUTIONARY MARKINGS

- #1 2986306 – Danger
- #2 2998429 – SOUTHWORTH
- #3 5904656 – 300 lb Capacity
- #4 2998433 – 500 lb Capacity
- #5 5904642 – SOUTHWORTH
- #6 2986968 – Name Plate

## LOAD CAPACITY

The load capacity is stamped into the identification plate located on the central cross-member, at the base of the actuator and capacity stickers on either side of the table. (figure 4) The ELPH contains an overload protection device that may cut power to

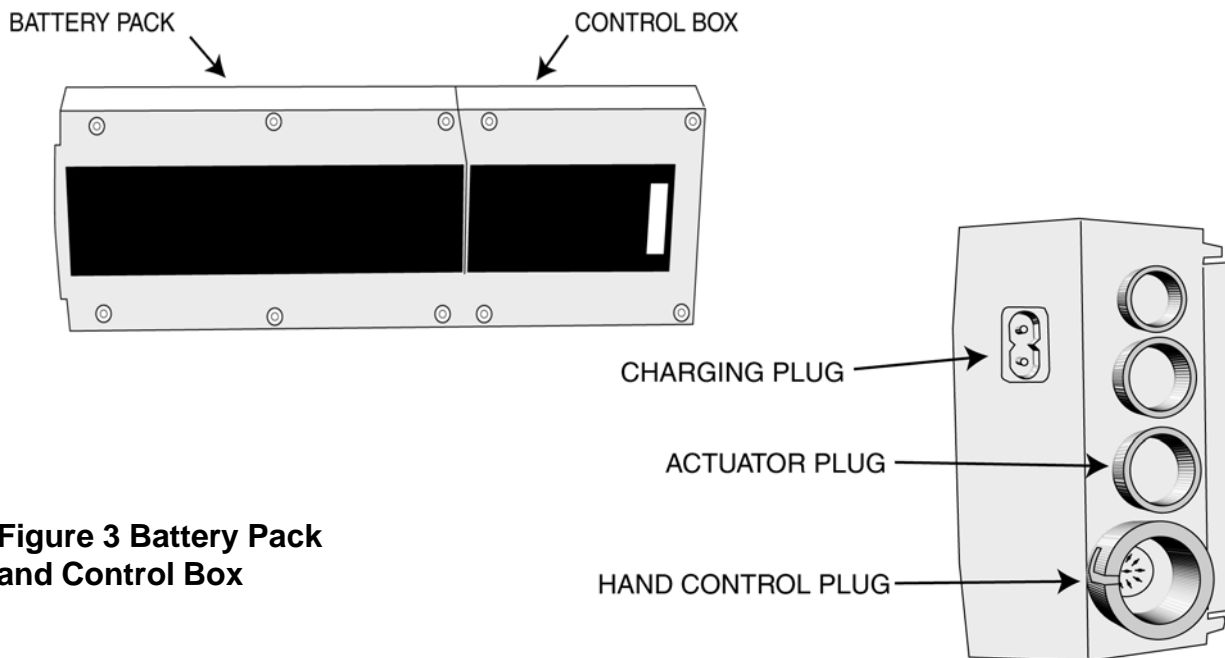

**Figure 3 Battery Pack and Control Box**

the unit if overloaded. If this occurs, make sure that the ELPH is not loaded beyond its capacity. The device will reset within a matter of seconds and power will be restored. The load capacity is based on the load applied centrally and uniformly to the platform.

**CAUTION!**

**Do not overload the ELPH, as this may damage the unit.**

**CAUTION!**

**Do not let loads significantly overhang the platform, as this could result in the platform being overloaded, and cause the ELPH to tip over.**

## MAINTENANCE

The shop ELPH requires minimal maintenance. The ELPH is designed for a life of approximately 10,000 cycles after which a new actuator may be required.

Daily inspection: Make sure there are no foreign objects in the way of the rollers and the scissor legs. Make sure all wires are plugged into the control box.

## MONTHLY MAINTENANCE

- 1) Check all welds, making sure they are intact, no cracks or broken spots.
- 2) Turn the ELPH on its side and check that the caster bolts are tight. If the caster with the direction lock requires tightening, engage the direction lock and ensure that the castor is pointing straight ahead before tightening.

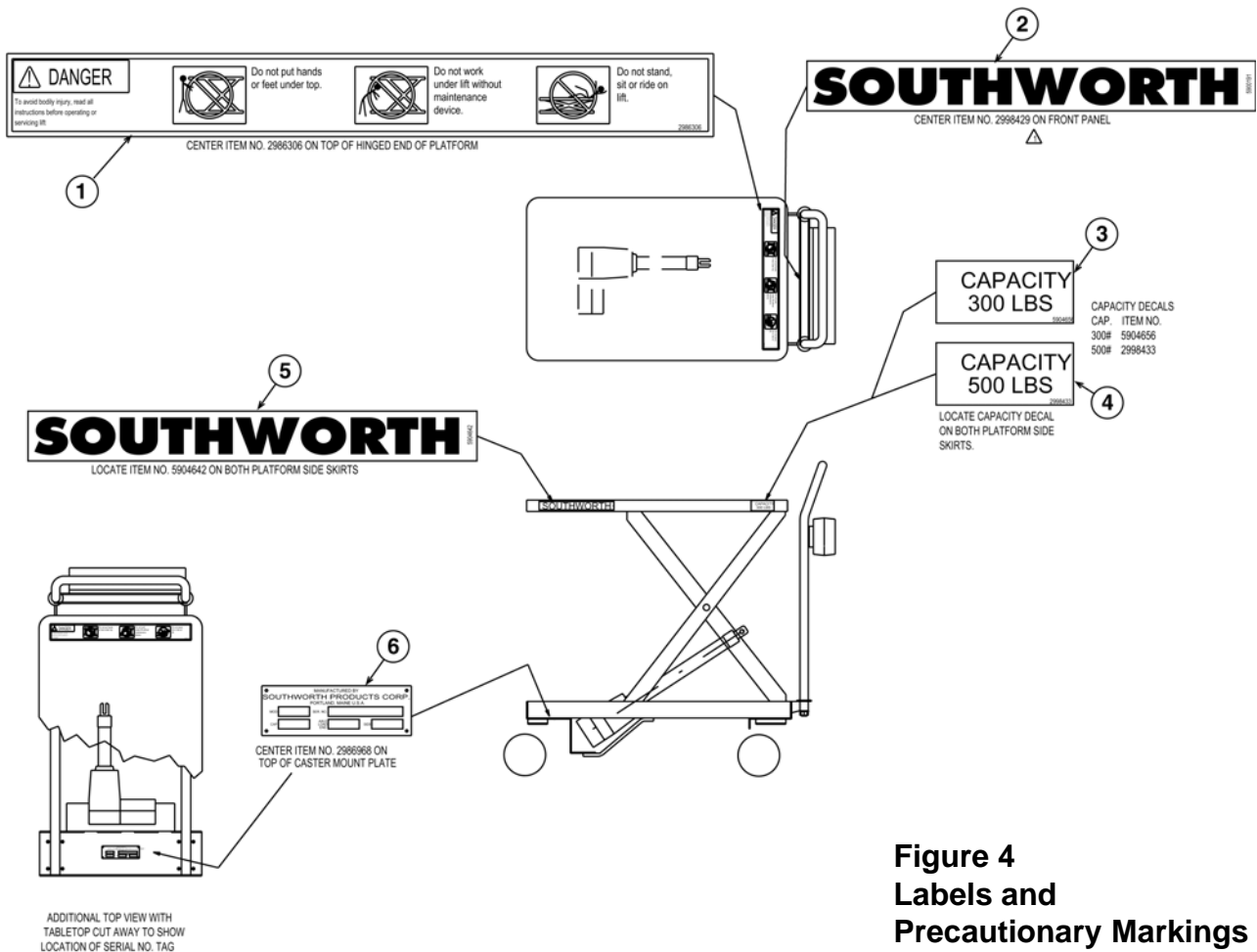

**Figure 4  
Labels and  
Precautionary Markings**

- 3) Check that the cotter pins on the actuator pivot bolts are in place.
- 4) Inspect the cable and plug for signs of damage.
- 5) Inspect the battery control box assembly for obvious signs of abuse.
- 6) Use a clean rag to wipe the paths along which the rollers travel.
- 7) Lubricate (WD-40) pivots and roller pins.

## TROUBLE SHOOTING

The shop ELPH should provide years of trouble-free service. However, in the event you experience difficulties with the ELPH, the following may help you identify the problem.

You may, of course, contact Southworth's Customer Service Dept. at 1-800-743-1000.

## ANNUALLY OR 3000 CYCLES

- 1) Dismantle.
- 2) Lubricate (WD-40) pivots and roller pins.
- 3) Clean.
- 4) Reassemble.

PROBLEM	POSSIBLE CAUSES	REMEDY
ELPH will not raise.	1) Power is not supplied to the actuator.	Check whether the power cable is plugged in.
	2) Batteries are discharged.	Recharge the batteries.
	3) An electrical fault may exist or the actuator may have burned out.	Contact Southworth Customer Service Dept. 1-800-743-1000.
ELPH is slow to raise or will not raise to the top.	1) Batteries are discharged.	Recharge the batteries.
	2) A fault may exist with the motor/ switch.	Contact Southworth Customer Service Dept. 1-800-743-1000.
ELPH will not lower.	1) Power is not supplied to the actuator.	Check whether the power cable is plugged in.
	2) Batteries are discharged.	Recharge the batteries.

## Ordering Replacement Parts

Southworth has carefully chosen the components in your unit to be the best available for the purpose. Replacement parts should be identical to the original equipment. Southworth will not be responsible for equipment failures resulting from the use of incorrect replacement parts or from unauthorized modifications to the machine.

Southworth can supply all replacement parts for your Southworth lift. With your order, please include the model number and the serial number of the unit. You will find these numbers on the name plate.

To order replacement parts, please call the Parts Department at (207) 878-0700. Parts are shipped subject to the following terms:

- FOB factory.
- Returns only with the approval of our parts department.
- Payment net 30 days (except parts covered by warranty).
- Freight collect (except parts covered by warranty).

Parts replaced under warranty are on a "charge-credit" basis. We will invoice you when we ship the replacement part, then credit you when you return the assumed substandard part.

Parts Department  
Southworth Products Corp  
P.O. Box 1380  
Portland, ME 04104-1380  
Telephone: (207) 878-0700  
FAX: (207) 797-4734  
[repairparts@SouthworthProducts.com](mailto:repairparts@SouthworthProducts.com)

# RETURN MATERIALS AUTHORIZATION (RMA) PROCEDURES

The Southworth Return Authorization (RMA) Procedure is provided as a courtesy to our customers in the event a product or a component may need to be returned.

If a customer wishes to return a Southworth product, the first step in the process is to request an RMA number from the Customer Service Department. This request must be made on or before the thirtieth (30th) calendar day following the date of Southworth's invoice for the merchandise being returned.

The RMA number must appear on the outside of any packaging material for a return to be accepted and processed at Southworth manufacturing facility. Customers shipping returns back to Southworth, from the continental US, Canada or Mexico have thirty (30) days from the effective date of the RMA to have the merchandise arrive freight prepaid at Southworth. If the RMA number is missing or expired (beyond 30 days) it may be refused at Southworth. If any RMA is expired, contact the Customer Service Department before returning to Southworth.

All RMA's are subject to the appropriate restocking fees. All credits issued are less restocking fees as applicable, plus any assessed outbound/inbound in-transit damages.

**Return addresses:** please refer to your RMA for the specific address to which your product should be returned. Southworth has multiple facilities and returning goods to other than the designated location will result in goods being refused.

Please contact the Customer Service Department at anytime regarding questions to this procedure.

Southworth Products Corp  
P.O. Box 1380  
Portland, Maine 04104  
PH: 1-800-743-1000 or 1-207-878-0700 FAX: 207-797-4734  
[www.SouthworthProducts.com](http://www.SouthworthProducts.com)

# 2 YEAR WARRANTY

Southworth Products Corp warrants this product to be free from defects in material or workmanship for a period of 2 years of single shift usage from date of shipment, providing claim is made in writing within that time period. This warranty shall not cover modified designs for special applications, failure or defective operation caused by misuse, misapplication, negligence or accident, exceeding recommended capacities, failure to perform required maintenance or altering or repairing, unless alteration is authorized by Southworth Products Corp. Except as set forth herein, there are no other warranties, express or implied, including the warranties of merchantability and fitness for a particular purpose, all of which are hereby excluded.

Southworth Products Corp makes no warranty or representation with respect to the compliance of any product with state or local safety or product standard codes, and any failure to comply with such codes shall not be considered a defect of material or workmanship under this warranty. Southworth Products Corp shall not be liable for any direct or consequential damages arising out of such noncompliance.

Southworth Products Corp's obligation under this warranty is limited to the replacement or repair of defective components at its factory or another location at Southworth Products Corp's discretion. This is buyer's sole remedy. Except as stated herein, Southworth Products Corp will not be liable for any loss, injury or damage to persons or property, nor for direct, indirect, or consequential damage of any kind, resulting from failure or defective operation of said product.

This warranty may be altered only in writing by Southworth Products Corp, Portland, Maine.



**SOUTHWORTH PRODUCTS CORP**

P.O. Box 1380, Portland, ME 04104-1380

Telephone: (800) 743-1000 • (207) 878-0700

Fax: (207) 797-4734

[www.SouthworthProducts.com](http://www.SouthworthProducts.com)

# **SOUTHWORTH**

**We'll Show You How**

Southworth is *the* world class supplier of products designed to improve productivity and enhance safety. Our staff has over 400 years of engineering experience. If one of our standard products does not meet your needs, we can design custom equipment specifically suited to your material handling application.



**Lift with Turntable**



**Portable Tilters**



**Palletizing**



**Dock Lifts**

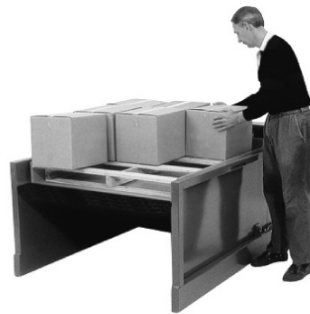

**Palletizing**



**Portable Lifts**



**Stretchwrapping**



**Positioning**

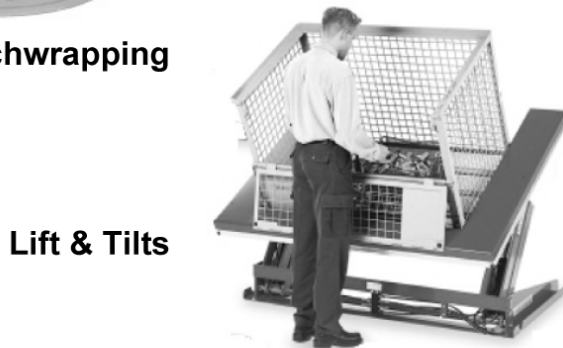

**Lift & Tilts**



**Floor to Mezzanine Lifts**

For more information, contact Southworth Products  
Telephone 800-743-1000 - Fax 207-797-4734  
Email: [sales@SouthworthProducts.com](mailto:sales@SouthworthProducts.com)