

SOUTHWORTH

We'll Show You How

Owner's Manual **Pneumatic PalletPal™** Level Loader



Model # _____

Serial # _____

Placed in Service _____

Southworth Products Corp

P.O. Box 1380 • Portland, Maine 04104-1380

Phone 800-743-1000 • 207-878-0700 Fax 207-797-4734

www.SouthworthProducts.com

service@SouthworthProducts.com

Feb 2008

This manual was current at the time of printing.
To obtain the latest, most updated version, please contact
Southworth's Customer Service Department or go
to our website: www.SouthworthProducts.com under
Parts & Service you will find a complete list of
current owner's manuals to print.

CONTENTS

INTRODUCTION	Page 4
SAFETY	4
Installation Notes	5
Operation Notes – Manual Use	5
INSTALLATION INSTRUCTIONS	6
Unpacking the Unit.....	6-7
Specifications.....	6
Setup and Instructions	7
Setup Procedures	8
Quick Setup	8
OPERATING INSTRUCTIONS	9
Loading Manually	9
Removing Loads Manually	9
Operating Safety – Manual Use	9
Loading with a Fork Lift	10
Unloading with a Fork Lift	10
Moving the Pneumatic PalletPal	10
TROUBLESHOOTING	11
Troubleshooting Check List	11
Maintenance.....	7
Ordering Replacement Parts	11
RETURN MATERIALS AUTHORIZATION (RMA)	12
WARRANTY	13

Tables

Setup Reference Table	8
-----------------------------	---

List of Figures

Figure 1	Safety Labels	5
Figure 2	Pinch Points	5
Figure 3	Loading Manually	9
Figure 4	Unloading Manually	9
Figure 5	Loading with a Fork Lift	10
Figure 6	Unloading with a Fork Lift	10
Figure 7	Moving the Pneumatic PalletPal	10
Figure 8	Warning - Load in Layers	9

INTRODUCTION

The Pneumatic PalletPal™ Level Loader is a simple device that will automatically maintain a load at the ideal height for manual loading and unloading. If a palletized load is placed on the unit, the unit gradually rises as boxes or parts are removed. This automatically maintains the top of the load at the correct working height.

The unit may also be used for the reverse application. An empty pallet may be placed on the Pneumatic PalletPal. The unit gradually lowers as boxes or parts are added. Again, this keeps the top of the load at the correct height. Complete pallets may be loaded or unloaded using a fork lift. See Figures 3 & 4.

This manual contains information to help you to learn about the safe and proper installation, use, and upkeep of your Pneumatic PalletPal unit. Please be sure that this manual is available to anyone who uses or services the unit.

Pneumatic PalletPal units may be used in a wide variety of industrial settings. The instructions in this manual are not necessarily all-inclusive, as Southworth cannot anticipate all conceivable or unique

situations. **In the interest of safety, please read this whole manual carefully. Be familiar with the contents of this manual before you install or use the Pneumatic PalletPal unit. If you are not sure of the proper procedure to be followed, please call Southworth Products Corporation for more information.**

Southworth's product warranty is shown on the rear cover of this manual. **This instruction manual is not intended to be or to create any other warranty, express or implied, including any implied warranty of merchantability or fitness for a particular purpose, all of which are hereby expressly excluded.** As set forth more specifically in the product warranty, Southworth's obligation under that warranty is **limited** to the repair or replacement of defective components, which shall be the buyer's **sole remedy**, and Southworth shall not be liable for any loss, injury, or damage to persons or property, nor for any direct, indirect, or consequential damage of any kind resulting from the Pneumatic PalletPal unit.

Safety

The Pneumatic PalletPal unit has been carefully designed to be as safe as possible for operators and service workers. If you take a few common-sense precautions, you will be able to use the unit safely. However, the Pneumatic PalletPal is a powerful unit with moving parts, and is capable of causing personal injury if proper precautions are not taken.

Therefore, throughout this manual, Southworth has identified certain hazards which may occur in the use and servicing of the Pneumatic PalletPal unit, and provided appropriate instructions or precautions which should be taken to avoid these hazards. In some cases, Southworth has also pointed out the consequences which may occur if Southworth's instructions or precautions are not followed. Southworth uses the following system of identifying the severity of the hazards associated with its products:

DANGER! Immediate hazard which will result in severe personal injury or death.

WARNING! Hazard or unsafe practice which could result in severe personal injury or death.

CAUTION! Hazard or unsafe practice which could result in minor personal injury or property damage.

Please read and follow this instruction manual, including all safety instructions and precautions, carefully and completely.

WARNING!

Do not inflate the system to more than 61 psi at the fully raised position. If the actuation system pressure is higher than 61 psi under any circumstance it may cause the failure of the air actuation system thus resulting in severe injury.

WARNING!

Never try to service the machine without carefully reading the maintenance part of this manual. Otherwise severe personal injury may result.

Figure 1 shows the safety labels on this unit. Please be sure that all of the labels are in place, and are visible to the machine operators. Never paint over the labels. If any of the labels are missing, please contact Southworth for replacements. **The safety labels help to protect your workers.**

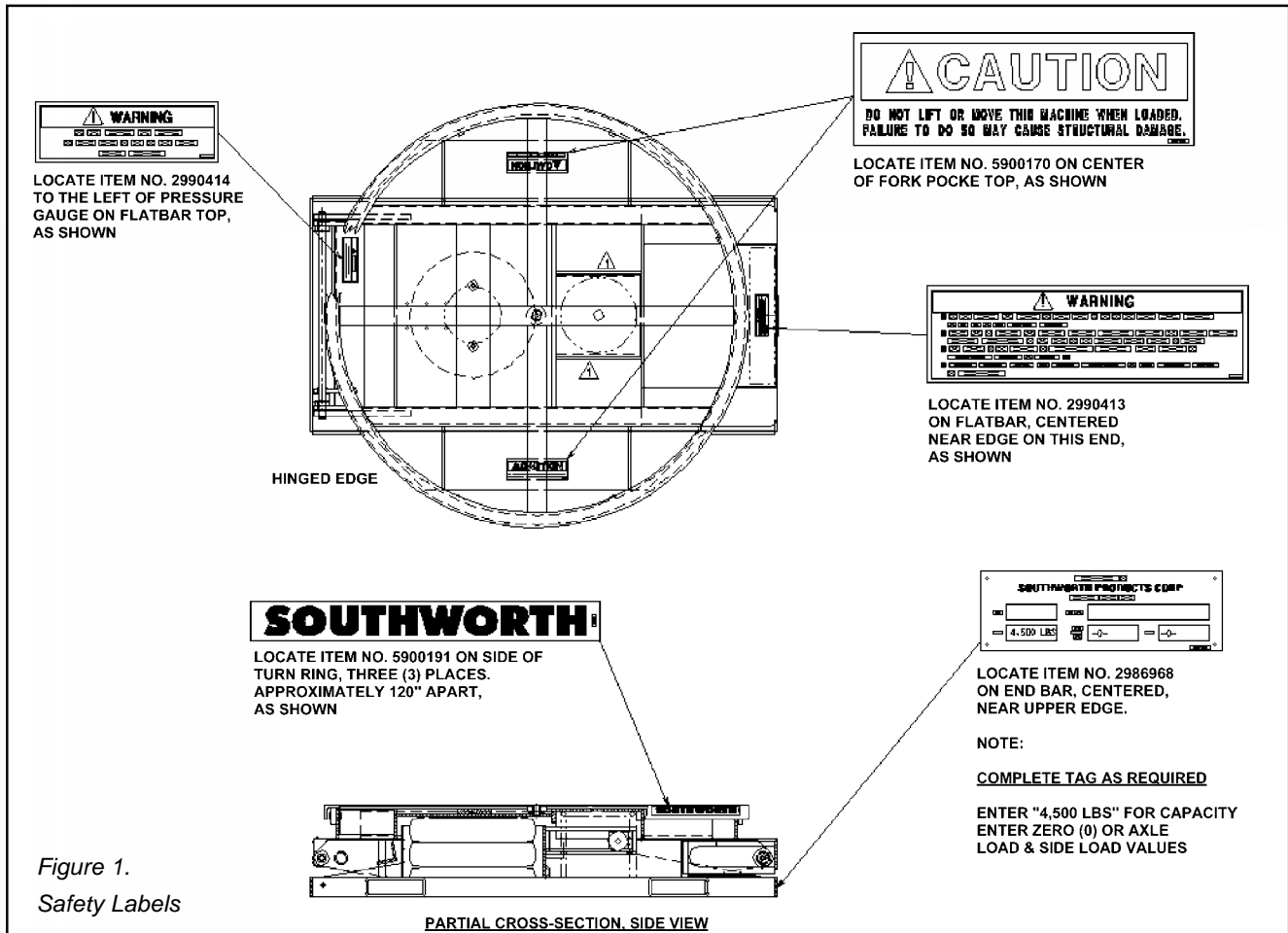

Figure 1.
Safety Labels

INSTALLATION NOTES

WARNING!

The unit is attached to the skid using metal bands. These bands are under high tension. The edges are sharp. Wear safety glasses and gloves when you handle or cut the banding.

CAUTION!

The unit must be installed on a firm level surface. The frame of the unit must sit firmly on the floor, and the floor must be level. If the frame is not supported correctly, stresses may develop in the frame. The unit may bind or not work easily. The rotating top may not rotate correctly.

OPERATION NOTES

WARNING!

Never sit or ride on the turntable or operate the unit if anyone is on it.

WARNING!

Never operate the unit if the load is off center. The load may shift, and you may be injured. This can also damage the unit.

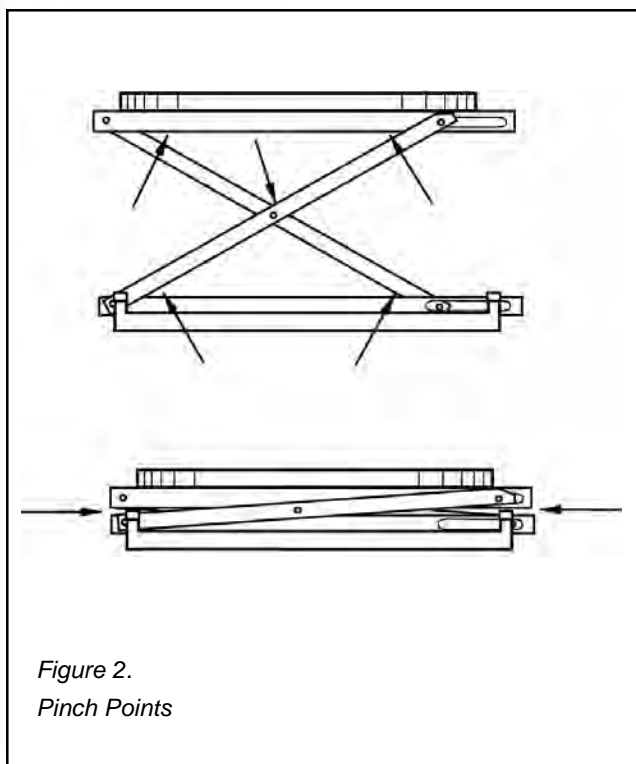

WARNING!

As the unit moves, keep away from the "pinch points" where metal parts meet. See Figure 2.

WARNING!

Keep the area around the unit clean. Do not allow any dirt, debris, spilled oil, or excess grease to collect. These materials may cause you to slip while the unit is operating, and you may be injured.

WARNING!

Stay clear of the turntable when it is moving. As the pallet turns, a part of the load may rotate around and hit you. Never turn the load when anyone is standing beside the unit.

WARNING!

Do not try to use this unit with damaged or broken pallets. Broken pallets may have boards or nails which hang down below the main part of the pallet. As the pallet is turned, these boards or nails may catch on the frame of the unit. This can cause the pallet to stop turning suddenly, causing the load to shift.

You may be injured, and the unit may be damaged. The boards or nails on the bottom of the pallet should not extend down more than 1/8 inch.

INSTALLATION INSTRUCTIONS

Unpacking the Unit

1. Before you start to install the unit, check for local codes and ordinances that may apply. It is your responsibility to obtain any necessary permits.
2. Please read all of these instructions carefully. Be sure to read and understand all of the warnings.
3. Inspect the shipping pallet carefully for any damage which may have affected the unit. If you see signs of damage, notify the shipper immediately. Also make a note of this on the shipping papers that you are asked to sign.
4. Choose the place where you want to mount the unit. It is very important that the Pneumatic PalletPal be set up on a smooth and flat surface. Check the floor surface carefully and make sure that it is free of all loose debris and dirt.

Specifications

Load capacity.....	400 to 4500 lbs.
Load size.....	50" wide x 50" long x 72" high (max.)
Length.....	45 1/4 inches
Width (base frame).....	36 1/4 inches
Compressed height.....	9 1/2 inches
Extended height.....	30 1/2 inches
Air source.....	62 psi
Maximum system air pressure.....	120 psi
Safety relief valve setting.....	125 psi
Rotating ring, outer diameter.....	43 5/8 inches
Rotating ring, inner diameter.....	40 5/8 inches
Ship weight.....	615 lbs
Operating environment.....	indoor
Operating temperature.....	+30 to +120F

WARNING!

The unit is attached to the skid using metal bands. These bands are under high tension. The edges are sharp. Wear safety glasses and gloves when you handle or cut the banding.

5. Remove the metal banding that secures the unit to the pallet. Remove all packing material. Shift the unit to the floor. Support the base as you do this.
6. Check to see that the base frame of the unit is sitting firmly on the floor. Try to move or rock the frame of the unit. The base frame should be stable, and should not move. Check to see that the base frame is level. If any part of the base frame is more than $\frac{1}{2}$ " out of level in relation to any other part, reposition to a flatter, more level surface area.
7. If you have any questions about the steps in the installation process, please call Southworth Customer Service at 1-800-743-1000.

Set-Up and Instructions

The Pneumatic PalletPal can be setup to handle pallet loads of any weight within the unit's capacity range. Load capacity depends on the initial actuator pressure. The actuator pressure can be set from 6 psi to 61 psi to achieve capacities ranging from approximately 100 lbs to 1000 lbs. Either an air compressor or shop air can be used as the air source to setup the unit. Maximum air pressure needed from the air source is 61 psi. Once air is inflated into unit's air actuation system, a corresponding load capacity can be set. The unit will then lower or rise as the load is being added or removed from the unit, and thus works as an automatic pallet leveler. A rule of thumb for setting up the unit is that the amount of air inflated into the air actuator should allow the unit to be lowered to its compressed height with load equal to 75% of the set capacity (including the weight of the pallet).

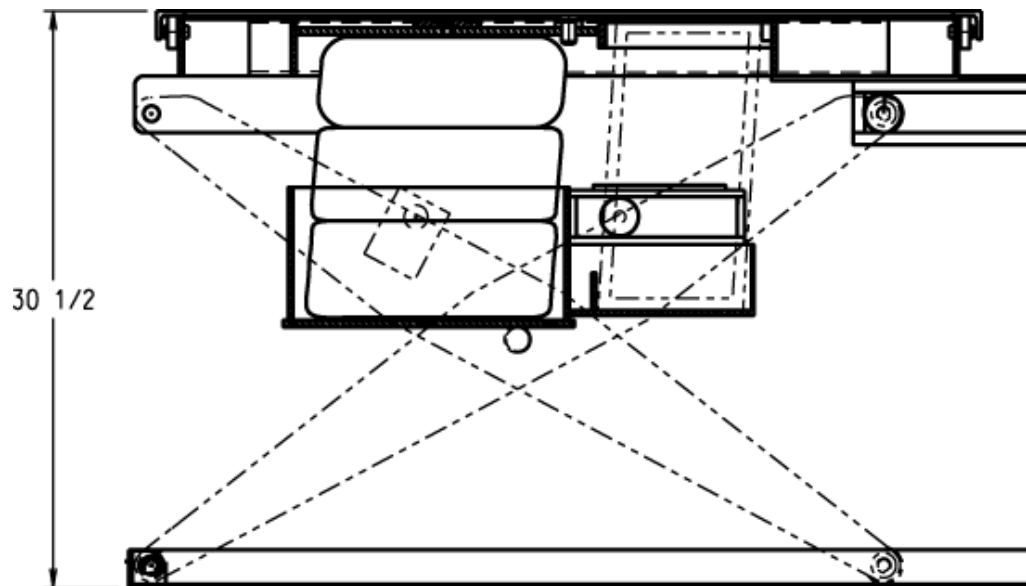

Maintenance

Routine Periodic Maintenance

Every 90 days -

- Check for loose hardware and signs of excessive wear.
- Check to be sure that the unit is placed on a firm level surface.

SET-UP REFERENCE TABLE

Capacity	<700	1000	1500	2000	2500	3000	3500	4000	4500
Capacity X 75%	-	750	1125	1500	1875	2250	2625	3000	3375
Initial Pressure (psi) (no load on unit)	7	11	18	26	34	42	49	56	62

Setup Procedures

1. The Pneumatic PalletPal must be properly installed according to the installation section of this manual.
2. With no load on the unit use shop air or an air compressor to pressurize the air actuation system to the required initial pressure. The unit is equipped with an air pressure gauge and an air manifold valve that includes a valve stem, a manual relief knob, and a safety relief valve. Add air to the actuator system through the valve stem, and release air from the system by loosening the manual relief valve.
3. Gradually load the Pneumatic PalletPal to 75% of the setup capacity. Check to see if the unit is fully compressed. If not, turn the manual relief knob to slowly bleed air out of the system until the platform reaches minimum, fully compressed height; then tighten the manual relief knob. The setup procedure is now complete and the Pneumatic PalletPal is ready for use.

4. If a different load is to be handled, or if the operator prefers a higher or lower loading/unloading position from that of the standard setup, add air to, or bleed air from the actuation system to achieve the necessary height. The gauge should never be more than 62 psi when the unit has no load on it.

** NOTE: The actuation system of the Pneumatic PalletPal contains captive air much like an automotive tire and will lose small amounts of air over time. Therefore, air may have to be occasionally added to the system to compensate for the loss.*

Quick Setup

If you do not know or cannot estimate the weight of the pallet load to be handled, use the following instructions: With no load on the unit, pressurize the actuation system to 62 psi. Place about half of the pallet load onto the unit, then slowly bleed air from the system using the manual relieve knob until the pallet reaches the most convenient height for the operator to continue loading the pallet.

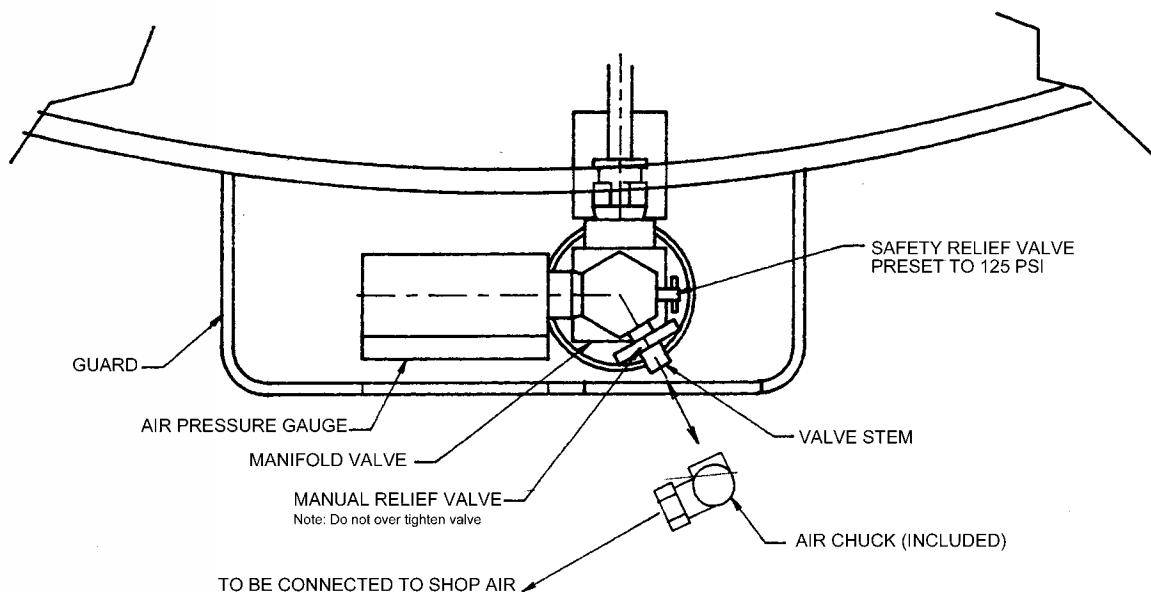

OPERATING INSTRUCTIONS

Loading Manually

Add boxes or parts until the pallet is full. The unit will gradually lower the pallet until it reaches the bottom. See Figure 3.

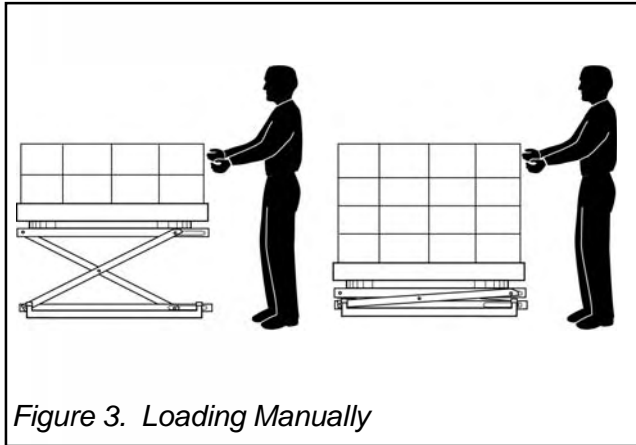

Figure 3. Loading Manually

Removing Loads Manually

Remove boxes or parts until the pallet is empty. The unit will gradually raise the pallet. See Figure 4.

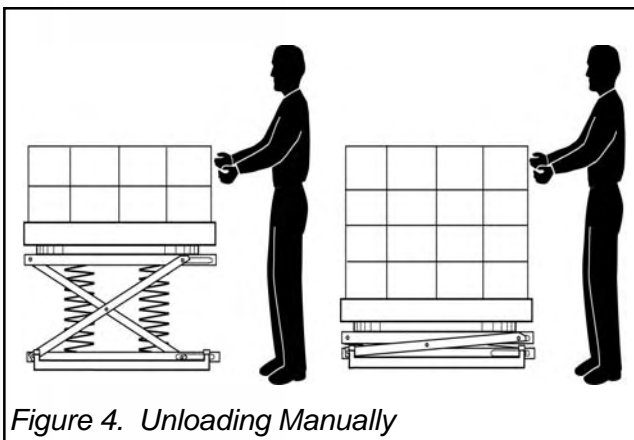

Figure 4. Unloading Manually

WARNING!

Ensure that loading and unloading of the Pneumatic PalletPal is done in even layers. Loading or unloading a load on one side may cause the load to tip over and you may be injured. This can also damage the unit.

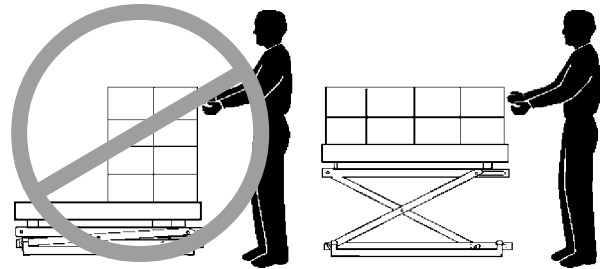

Figure 8. Warning - Load in Layers

Operating Safety -- Manual Use

1. Never push the load off of the side of the unit. If you do this, the frame of the unit may jump upward.
2. Never use the unit when anyone is sitting or riding on the turntable.
3. Do not try to use this unit with damaged or broken pallets. Broken pallets may have boards or nails which hang down below the main part of the pallet. As the pallet is turned, these boards or nails may catch on the frame. The pallet may stop turning suddenly and this can cause the load to shift. You may be injured and the unit may be damaged. If the boards or nails on the bottom of the pallet extend down more than $\frac{1}{8}$ inch, they will interfere with the turning action.
4. Stay clear of the turntable when it is moving. As the pallet turns, a part of the load may rotate around and hit you.
5. Keep the area around the unit clean. Do not allow any dirt, debris, spilled oil, or excess grease to collect. These materials may cause you to slip while the unit is operating and you may be injured.

Loading with a Fork Lift

1. Place the load on the lift, then lower the fork lift. Before removing the load, be sure the unit is carrying the weight, not the fork lift. See Figure 5.

- Lower the load until the airbag on the Pneumatic PalletPal is fully compressed.
- Be sure the forks on the lift are clear of the inside of the pallet.

WARNING!

If you skip these steps, the load may drop suddenly when you remove the fork lift. You may be hurt or the unit or load may be damaged.

WARNING!

Never drop the load on the turntable. If you do this while the turntable is moving, the load may shift. You may be injured or the unit may be damaged.

2. Be sure the load is centered on the turntable.

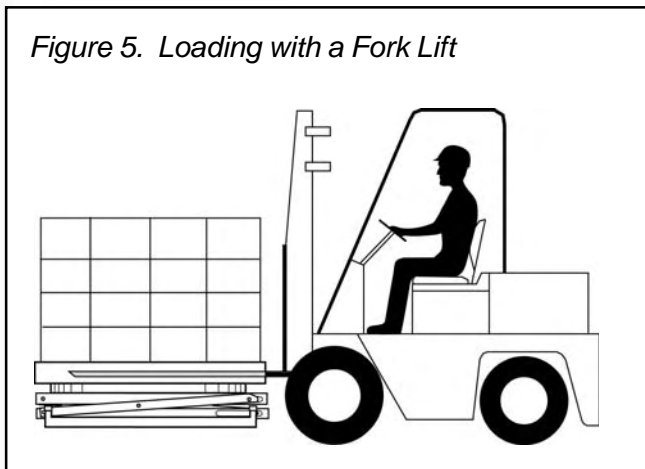

Figure 5. Loading with a Fork Lift

WARNING!

If the load is off-center, it may shift when the turntable is turned. You may be hurt or the unit or load may be damaged.

1. Insert the forks into the pallet, and lift the pallet clear of the top of the unit. See Figure 6.
 - Be sure the pallet clears the top of the turntable before you move the fork lift.

WARNING!
If you skip these steps, the unit may jump up suddenly when you remove the pallet. You may be hurt or the unit or load may be damaged.

Unloading with a Fork Lift

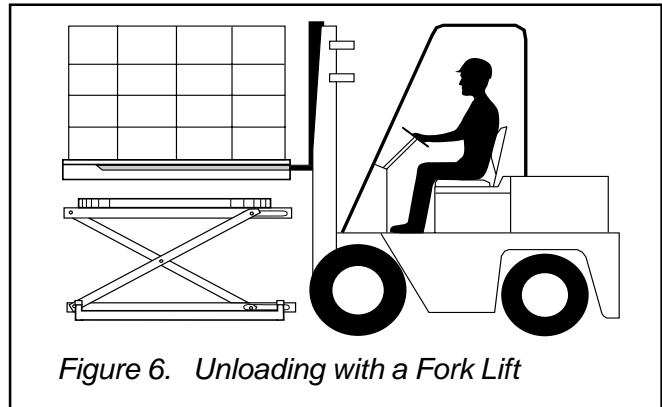

Figure 6. Unloading with a Fork Lift

Moving the Pneumatic PalletPal

CAUTION!

Do not move the Pneumatic PalletPal while it is loaded. This will damage the base frame of the unit. The pockets on the base frame are designed to support an unloaded Pneumatic PalletPal, but cannot support any extra weight.

1. Remove any load from the top of the Pneumatic PalletPal.
2. Insert the forks into the pockets in the base frame. See Figure 7.

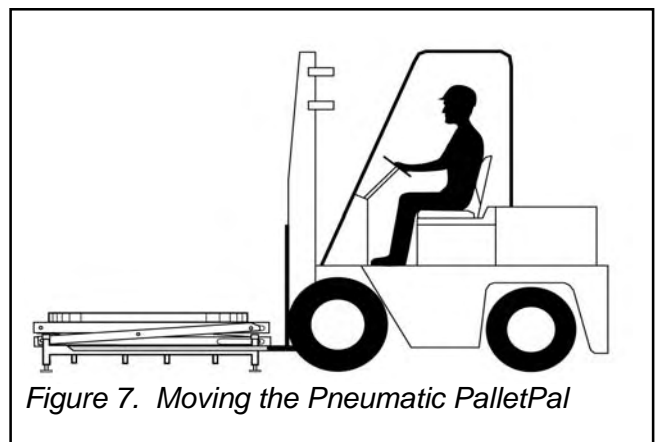

Figure 7. Moving the Pneumatic PalletPal

Troubleshooting

Troubleshooting Check List		
<i>Problem</i>	<i>Possible Cause</i>	<i>Check This</i>
The unit lowers too easily (too early)	Not enough air pressure	See set-up procedure pg 8
The unit does not lower enough (too late)	Too much air pressure	See set-up procedure pg 8
The top of the unit rotates away from you.	The base frame of the unit may not be level.	Move the unit to a level surface or install the optional adjusting feet.
Excessive "rumble" when unit operates.	Wear or lack of lubrication to bearings under turntable.	Remove turntable, replace bearings.
Wear on underside of turntable.	Normal condition caused by wear-hardening of metal.	No repair necessary.

Ordering Replacement Parts

Southworth has carefully chosen the components in your unit to be the best available for the purpose. Replacement parts should be identical to the original equipment. Southworth will not be responsible for equipment failures resulting from the use of incorrect replacement parts or from unauthorized modifications to the unit.

Southworth can supply all replacement parts for your PalletPal. With your order, please include the model number and the serial number of the unit. You can find these numbers on the name plate. This plate is located within the scissors mechanism.

To order replacement parts, please call the Parts Department at (207) 878-0700 or (800) 743-1000. Parts are shipped subject to the following terms:

- FOB factory
- Returns only with the approval of our parts department.
- Payment net 30 days (except parts covered by warranty).
- Freight collect (except parts covered by warranty).

Parts replaced under warranty are on a "charge-credit" basis. We will invoice you when we ship the replacement part, then credit you when you return the worn or damaged part.

Southworth Products Corp.
 P.O. Box 1380, Portland, ME 04104-1380
www.SouthworthProducts.com
 Email: service@SouthworthProducts.com
 Telephone: (800)-743-1000 or (207)-878-0700
 Fax: (207)-797-4734

RETURN MATERIALS AUTHORIZATION (RMA) PROCEDURES

The Southworth Return Authorization (RMA) Procedure is provided as a courtesy to our customers in the event a product or a component may need to be returned.

If a customer wishes to return a Southworth product, the first step in the process is to request an RMA number from the Customer Service Department. This request must be made on or before the thirtieth (30th) calendar day following the date of Southworth's invoice for the merchandise being returned.

The RMA number must appear on the outside of any packaging material for a return to be accepted and processed at Southworth manufacturing facility. Customers shipping returns back to Southworth, from the continental US, Canada or Mexico have thirty (30) days from the effective date of the RMA to have the merchandise arrive freight prepaid at Southworth. If the RMA number is missing or expired (beyond 30 days) it may be refused at Southworth. If any RMA is expired, contact the Customer Service Department before returning to Southworth.

All RMA's are subject to the appropriate restocking fees. All credits issued are less restocking fees as applicable, plus any assessed outbound/inbound in-transit damages.

Return addresses: please refer to your RMA for the specific address to which your product should be returned. Southworth has multiple facilities and returning goods to other than the designated location will result in goods being refused.

Please contact the Customer Service Department at anytime regarding questions to this procedure.

Southworth Products Corp
P.O. Box 1380
Portland, Maine 04104
PH: (800)-743-1000 or (207)-878-0700 FAX: (207)-797-4734
www.SouthworthProducts.com

2 YEAR WARRANTY

Southworth Products Corp warrants this product to be free from defects in material or workmanship for a period of **2 years** of single shift usage from date of shipment, providing claim is made in writing within that time period. This warranty shall not cover modified designs for special applications, failure or defective operation caused by misuse, misapplication, negligence or accident, exceeding recommended capacities, failure to perform required maintenance or altering or repairing, unless alteration is authorized by Southworth Products Corp. Except as set forth herein, there are no other warranties, express or implied, including the warranties of merchantability and fitness for a particular purpose, all of which are hereby excluded.

Southworth Products Corp makes no warranty or representation with respect to the compliance of any product with state or local safety or product standard codes, and any failure to comply with such codes shall not be considered a defect of material or workmanship under this warranty. Southworth Products Corp shall not be liable for any direct or consequential damages arising out of such noncompliance.

Southworth Products Corp's obligation under this warranty is limited to the replacement or repair of defective components at its factory or another location at Southworth Products Corp's discretion. This is buyer's sole remedy. Except as stated herein, Southworth Products Corp will not be liable for any loss, injury or damage to persons or property, nor for direct, indirect, or consequential damage of any kind, resulting from failure or defective operation of said product.

This warranty may be altered only in writing by Southworth Products Corp, Portland, Maine.

SOUTHWORTH
We'll Show You How

SOUTHWORTH PRODUCTS CORP
P.O. Box 1380, Portland, ME 04104-1380
Telephone: (800) 743-1000 • (207) 878-0700
Fax: (207) 797-4734
www.SouthworthProducts.com

SOUTHWORTH

We'll Show You How

Southworth is *the* world class supplier of products designed to improve productivity and enhance safety. Our staff has over 400 years of engineering experience. If one of our standard products does not meet your needs, our engineers can custom design equipment specifically suited to your material handling application.



Spring Load Leveler



Lift with Turntable



Portable Tilters



Dock Lifts



Palletizing



Portable Lifts



Stretchwrapping



Positioning



Lift & Tilt



Floor to Mezzanine Lifts

For more information, contact Southworth Products
Telephone (800) 743-1000 or Fax (207) 797-4734

Email: sales@SouthworthProducts.com