

SOUTHWORTH

We'll Show You How

OWNER'S MANUAL

RollE2.5-32 & RollE4-32



Model # _____

Serial # _____

Placed in Service _____

SOUTHWORTH PRODUCTS CORP

P.O. Box 1380, Portland, Maine 04104-1380

Phone (800) 743-1000 • (207) 878-0700 • Fax (207) 797-4734

www.SouthworthProducts.com

E-mail: service@SouthworthProducts.com

April 2006

Southworth Products Corp is widely acknowledged as the leading maker of hydraulic lifts and materials-handling equipment. Southworth machines are rugged and reliable, and are designed to provide years of trouble-free service. The designs are based on extensive engineering experience. These are good reasons for specifying Southworth machines in your plant.

Contents

INTRODUCTION	Page 4
SAFETY	4
Safety Regulations/Requirements	5
Safe Servicing of RolIE	5
INSTALLATION INSTRUCTIONS	6
Preparation	6
Assembly	7
MAINTENANCE	14
Hydraulic Oil Specifications	14
TROUBLESHOOTING	15
Ordering Replacement Parts	16
RETURN MATERIAL AUTHORIZATION (RMA)	17
WARRANTY	Back Cover

List of Figures

Figure 1a Safe Servicing of the Lift	6
Figure 1b Safe Servicing of the Lift	6
Figure 2 Safe Loading and Unloading	7
Figure 3 Labels and Precautionary Markings	8
Figure 4 Wiring Diagram-Single Phase (115/230 AC)	9
Figure 5 Wiring Diagram-3 Phase (115/230 AC)	9
Figure 6 Hydraulic Power Unit -Single Phase	10
Figure 7 Hydraulic Power Unit -Single Phase	11
Figure 8 Hydraulic Power Unit -Three Phase (460V)	12
Figure 9 Hydraulic Power Unit-Single Phase (115V)	14

Introduction

This manual contains information to acquaint you with the safe and proper installation, use, and upkeep of the machine. You should ensure that this manual is available to personnel working with the machine and require its use by these personnel.

In the interest of safety, please read this entire manual carefully, and be familiar with its contents before you install, use, or service the machine. If you have any questions about any instructions in this manual, please contact your dealer or Southworth Products Corporation.

Southworth's product warranty is provided in the back of this manual. This instruction manual is **not intended to be or to create any other warranty, expressed or implied, including any implied warranty of merchantability or fitness for a particular purpose, all of which are hereby expressly excluded.**

As set forth more specifically in the product warranty. Southworth's obligation under that warranty is **limited** to the repair or replacement of defective components, which shall be the buyer's **sole remedy. Southworth shall not be liable for any loss, injury, or damage to persons or property, nor for any direct, indirect, or consequential damage of any kind resulting from the lift table.**

Safety

In the interest of safety, please read this entire manual carefully. Please understand the material in this manual before you operate the Southworth RollE. Please be sure that everyone who uses or services the RollE has read this manual. If you have any questions about any of the instructions in this manual, please contact your dealer or the Southworth Products Corporation.

Safe Servicing of the Lift

Southworth is concerned about the safety of everyone that operates, maintains, repairs, or works near a Southworth lift. Blocking the lift is the only safe way to perform service or maintenance. In this manual, we will refer you to this procedure many times. In the interest of safety please follow all of these steps whenever you work under the RollE:

Warning! 

As the lift moves up and down, pinch points are created. If you are standing too close to the lift when it is moving, your arm or leg may be caught in the moving parts, and you may be hurt. Stay away from the pinch points when the lift is moving.

Warning! 

Be sure to use both the left and right maintenance device. Both the left and right devices

supplied with your machine must be used to support the table safely.

1. Remove the payload from the tabletop.
2. Raise the RollE platform to the full-up position. Don't let the table stop part way up.
3. Move the maintenance devices into a vertical position. Lower the table so the maintenance device is resting firmly between the tabletop and the base. With the maintenance devices properly installed the pressure in the hydraulic system will be relieved. If you do not do this, pressure may remain in the hydraulic system. If this pressure is released suddenly, you may be hurt, or the RollE may be damaged. Once in position the devices will keep the legs from moving, and prevent the lift from dropping suddenly.
4. Complete the work under the lift, then reverse the process to get the RollE ready for operation.
5. Repeat this process very time you must work under the coil car. **Do this even if you will only be under the table for a moment!**

Safety Regulations/Requirements

There is a built-in safety function in the safety frame. If the safety frame is touched on its way down, the table stops immediately. To continue lowering, the table has to be raised a little to be able to lower again.

RollE tables are always delivered with a control unit of the “deadman” type, which means that when the up or down button (or foot pedal on a footswitch control) is released the table will stop immediately.

Employee and employer must ensure it that risk of trapping does not occur during installation use or maintenance of the lifting equipment.

1. Do not exceed the lifting capacity. The load must be fixed – Max load + load evenly distributed.
2. Check the action of the safety frames and the distance around the equipment to eliminate the risk trapping.
3. Precautionary labeling must be legible.
4. Check for damage due to overloading.
5. Check and maintain cables and hoses.
6. Check for oil leakage. Grease if necessary.
7. Clean the lift table.
8. When the load is wheelborne, or there is a likelihood that the load may start to roll, the platform should be fitted with a stop or restraint to prevent load from moving.
9. Tilting platforms must include a fixed method of retaining the load.
10. **Hazard – no hands or feet under the platform.**

Safe Servicing of RollE



WARNING !

Only authorized personnel should perform inspection or maintenance and service procedures. Unauthorized personnel attempting these procedures do so at the risk of severe injury or death.



DANGER !

Failure to properly adhere to lift blocking procedures is to risk the sudden and uncontrolled descent of the lift during maintenance or inspection. A falling lift can cause severe injury or death.

This procedure describes the only factory-approved method of working under a lift. Follow these instructions **EVERY** time you plan to reach or crawl beneath the lift to perform service or maintenance – no matter how momentary that might be.

If the factory-provided maintenance device is damaged or missing, stop immediately and consult the fac-

tory for assistance. The manufacturer is not liable for your failure to use the approved maintenance device(s) and procedures that have been provided.

1. Any load must be removed from the lift prior to engaging the maintenance device(s). These devices are designed to support an unloaded lift only. Failure to remove the load from the lift prior to blocking could cause the failure of the maintenance device(s) and allow the lift to fall unexpectedly. This can result in personal injury or death, or permanent damage to the maintenance device(s) and/or the lift.
2. Raise the lift to its fully raised position. If you do not, the maintenance device(s) may not be able to be placed properly in its/their designed blocking position.
3. Remove the maintenance device(s) from its/their storage location and place it/them into the engaged position as shown in Figure 1. (Note: further infor-

mation may be useful here to provide additional instructions as to the location and method of storage and engaged positions).

- Lower the lift until it makes complete contact with the maintenance device(s). Re-check to ensure that all provided devices are fully and securely engaged. If the device(s) is/are not fully engaged the lift could fall unexpectedly, resulting in permanent damage to the device(s) or the lift.

DANGER!

If for any reason you are unable to lower the lift completely onto the maintenance device(s), stop immediately and consult the factory. Failure to properly use the factory approved maintenance device(s) could result in severe injury or death.

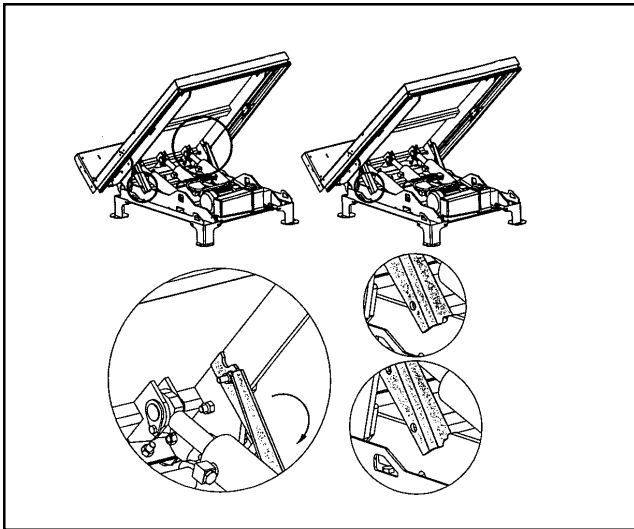

Fig. 1a Safe Servicing of the Lift

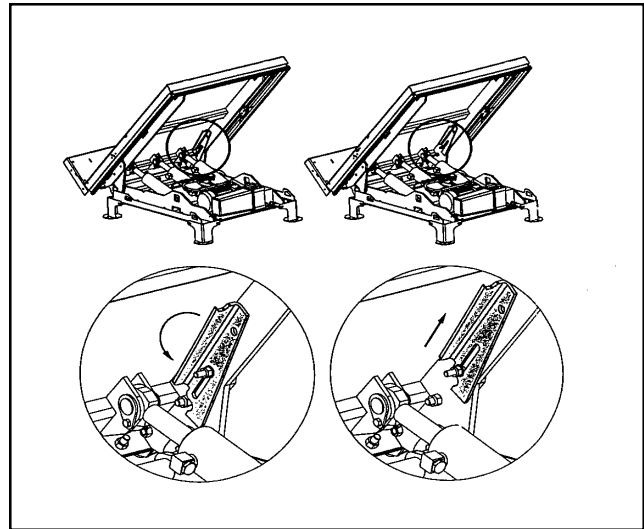

Fig. 1b Safe Servicing of the Lift

Installation Instructions

Preparation

Before you start to use the unit, check for local codes and ordinances which may apply. It is your responsibility to obtain any necessary permits.

Read all of these installation instructions carefully. Be sure to read and understand all of the warnings.

The unit should only be used indoors, or it should be protected from the weather.

DANGER!

The AC-powered unit has parts which carry 115 volts or more. This voltage can kill you! Don't work with the electrical parts unless you are a qualified electrician.

WARNING!

Protect the unit from rain or moisture. If the electrical parts in the power unit get wet, workers may be hurt by electrical shock. The electrical parts may fail if they are wet.

CAUTION!

This unit has an electric motor that can create sparks. Don't use the unit in an area where flammable gases may be present.

Remove the shipping material and remove the unit from the skid. You will need a crane or lift truck that can lift the unit safely.

CAUTION!

Do not try to move the lift by supporting the tilt platform. One end of the tilt platform is free.

On the front of this manual, write down the model number, serial number, and date the unit is placed in service. Figure 1 shows the location of the name plate.

Assembly

1. The RollE must always be securely fixed to the ground or floor with expander bolt or anchor.
2. Run the lift to its upper position and lock it. See instructions for locking device.
3. A competent electrician must make the installation of the electrical system.
4. Test the function of the safety frame on all sides.
5. Max load = evenly distributed load.
6. Recommendation - control unit should be installed to have a good view when the lift is moving.

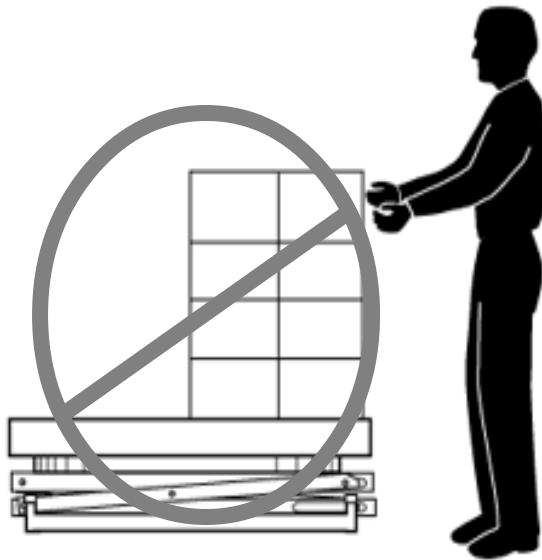

Fig. 2 Safe Loading and Unloading

WARNING!
Ensure that loading and unloading of the RollE is done in even layers. Loading or unloading a load on one side may cause the load to tip over and you may be injured. This can also damage the unit.

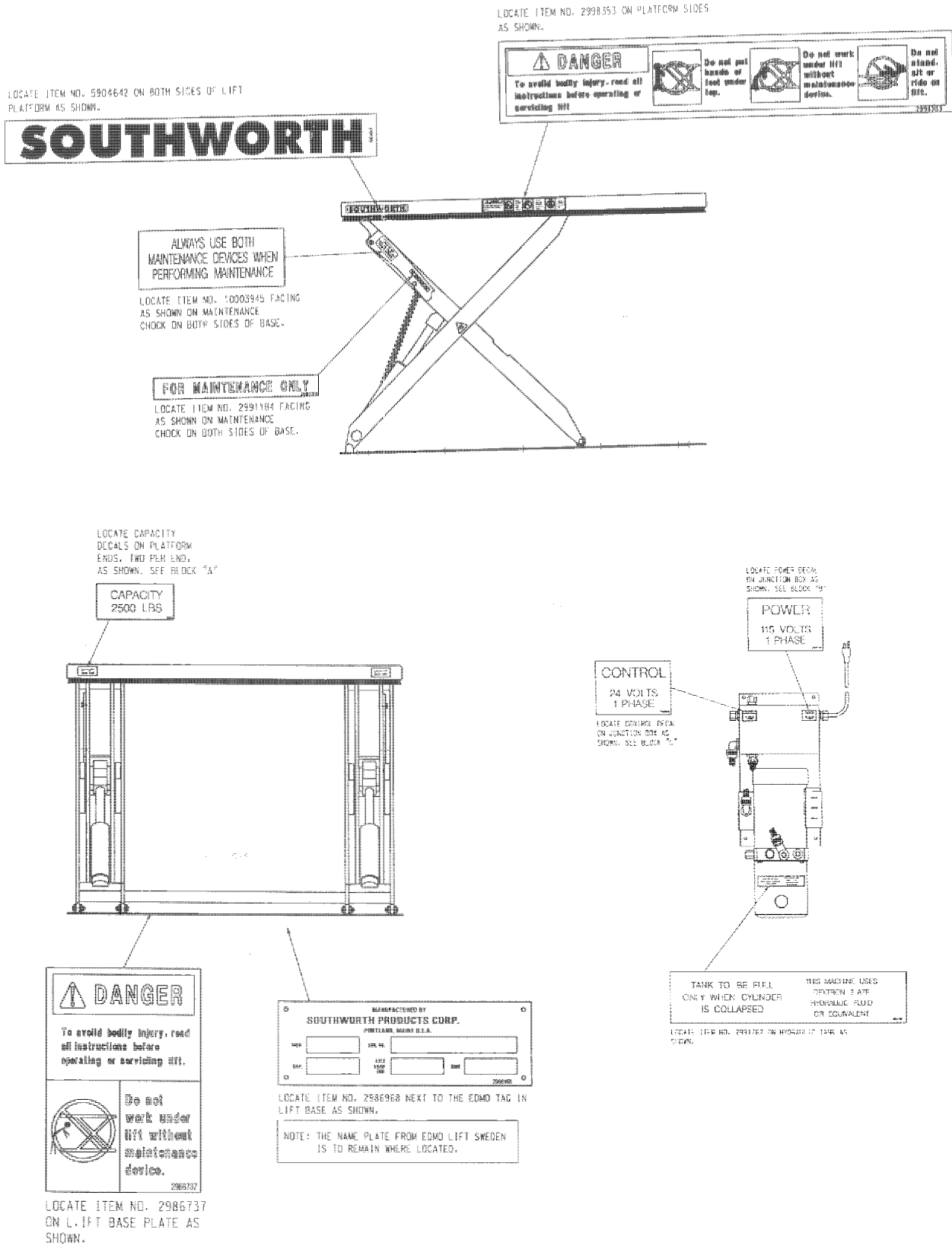

Fig. 3 Labels and Precautionary Markings

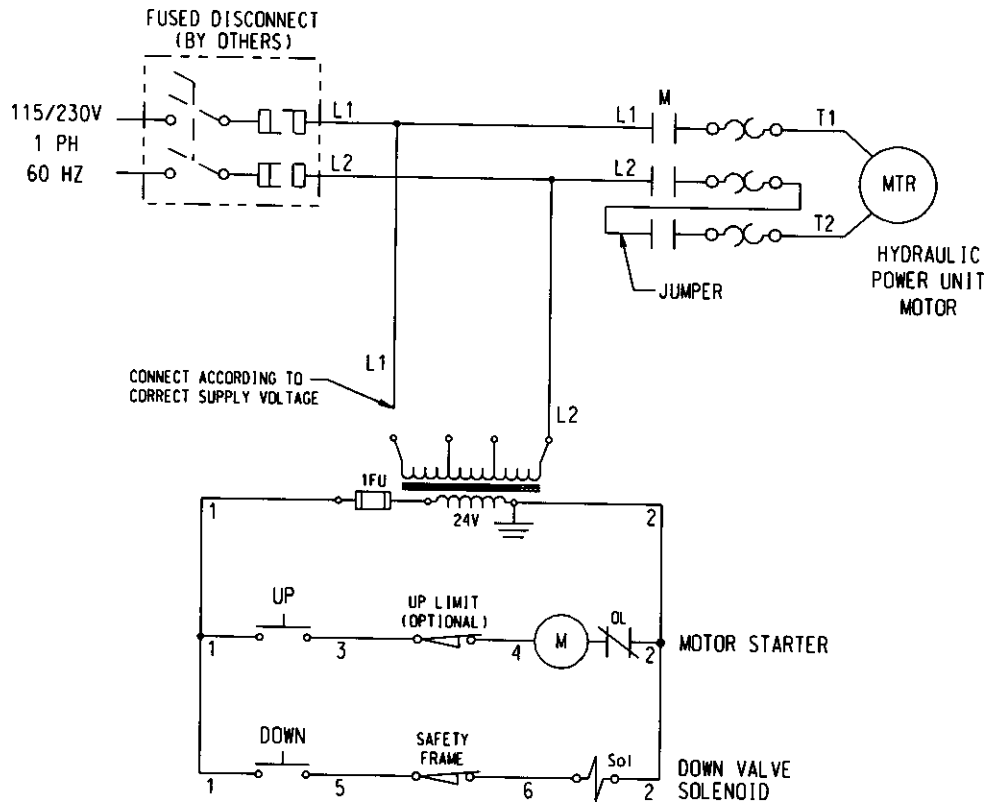

Fig. 4 Wiring Diagram 115/230 AC Single Phase

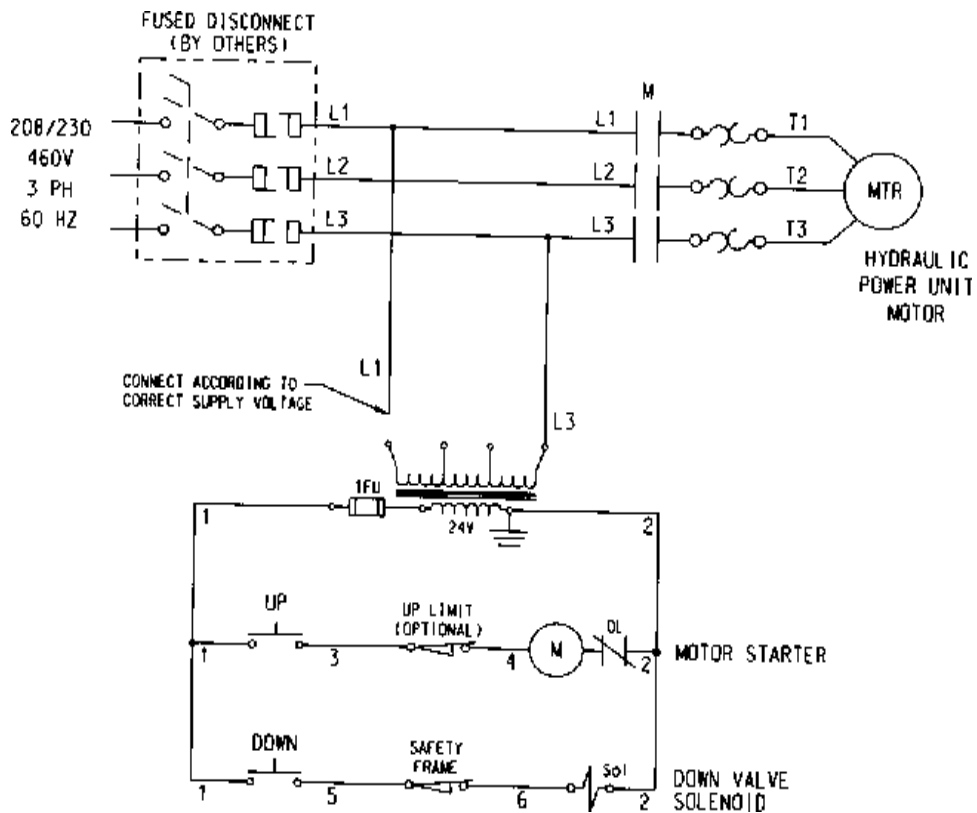

Fig. 5 Wiring Diagram for 115/230 AC Three Phase

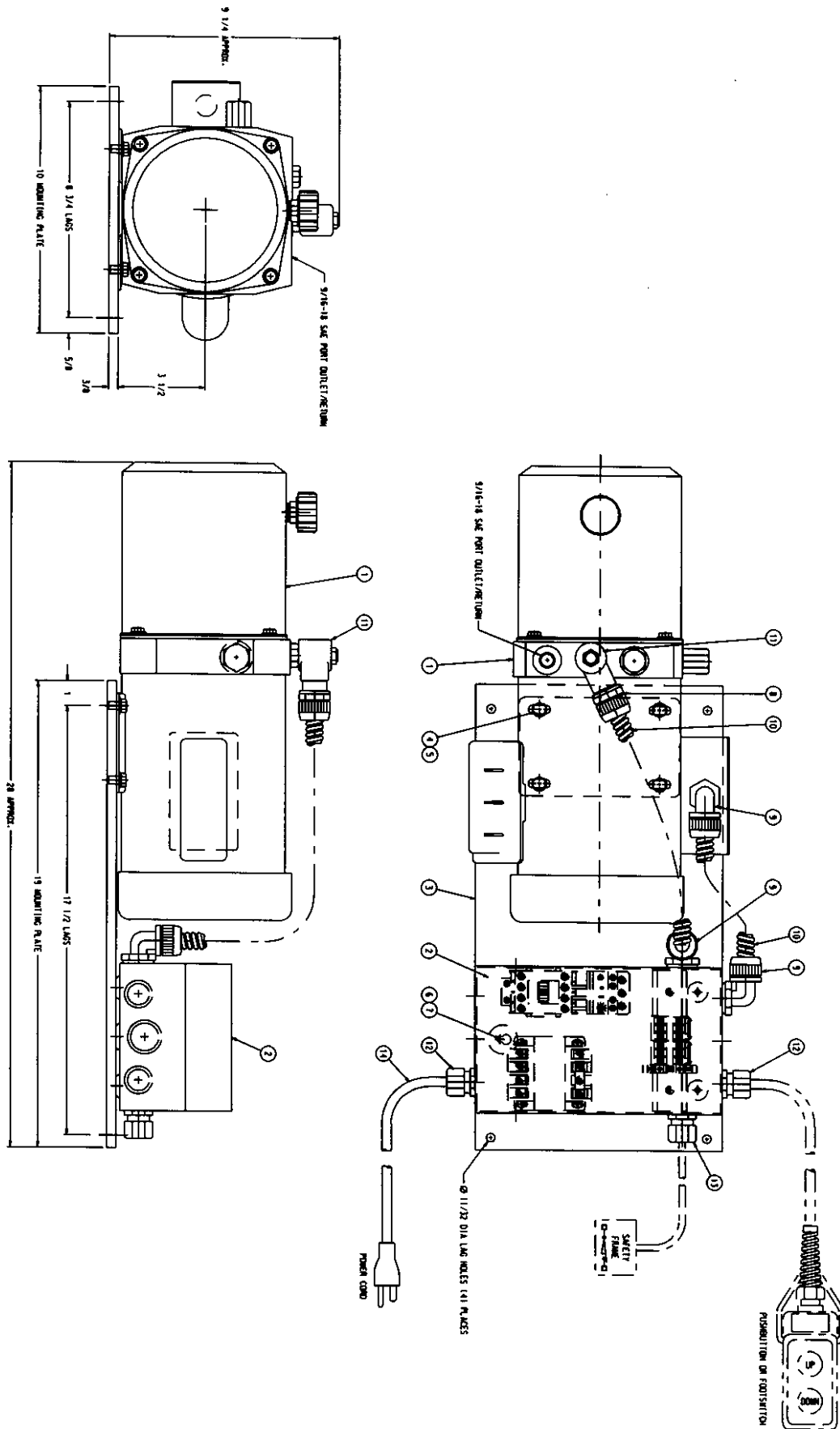

Fig. 6 Hydraulic Power Unit for 115V, Single phase

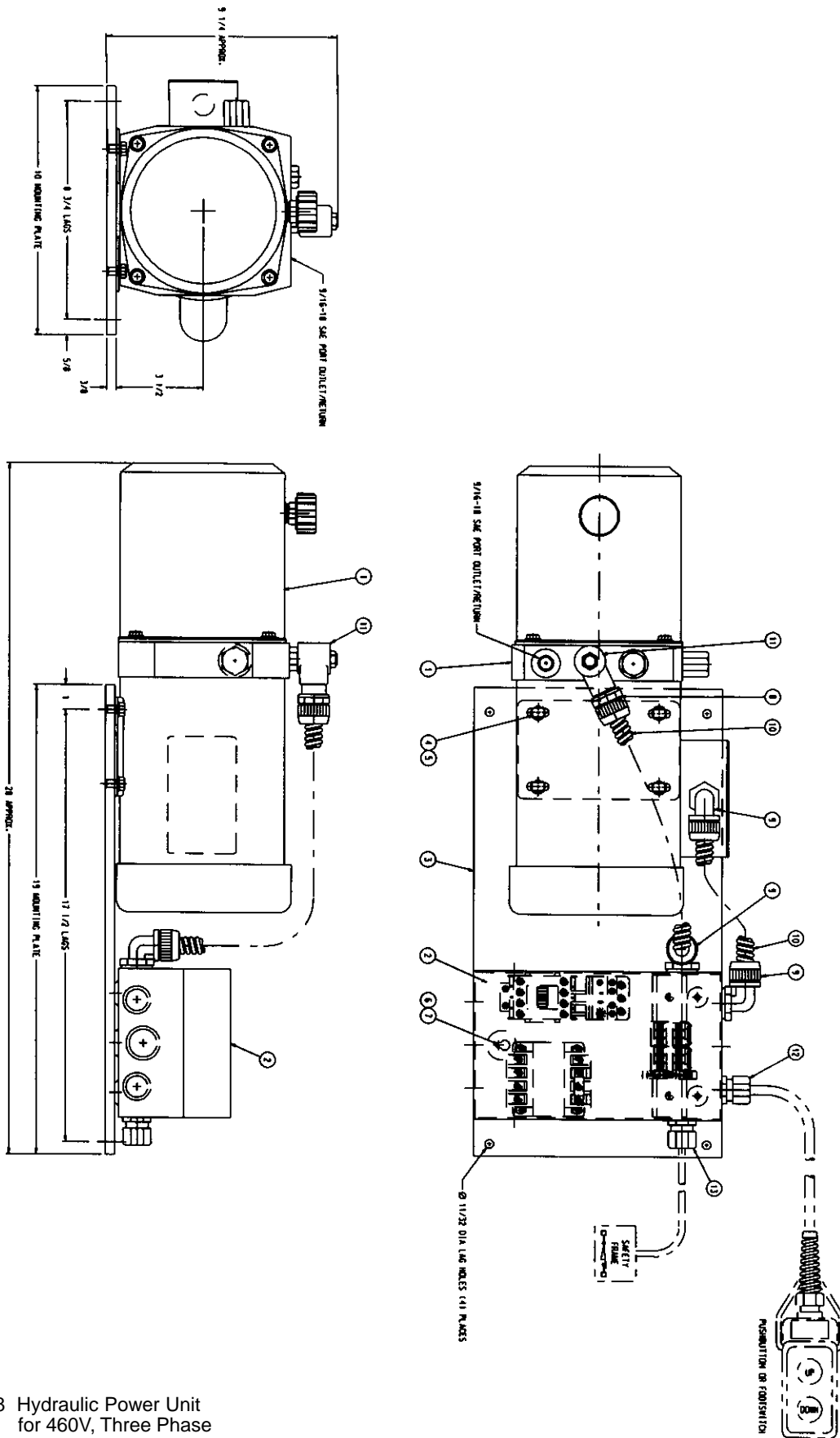
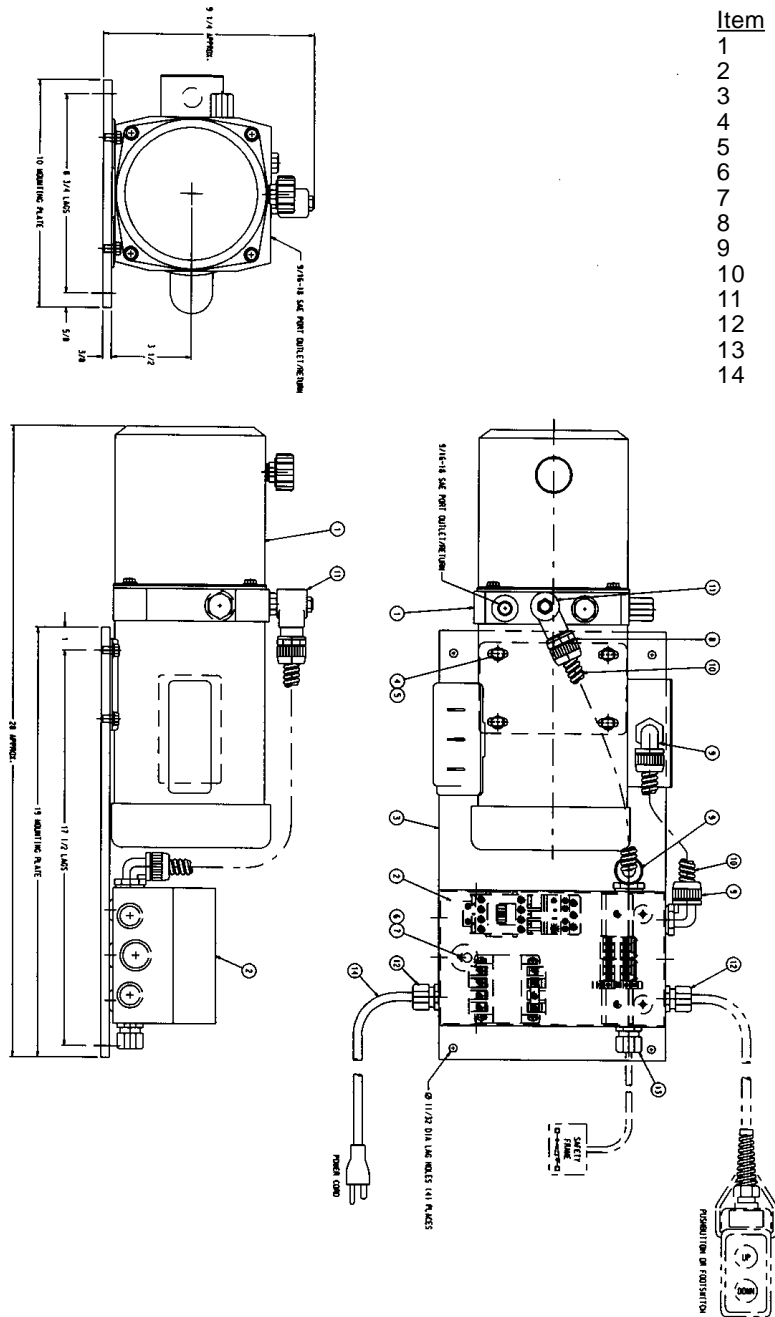

Fig. 8 Hydraulic Power Unit for 460V, Three Phase



Item	Quantity	Description
1	1	Hydraulic Power Unit
2	1	Control Panel
3	1	Mounting Plate
4	4	Screws
5	4	Lock Washers
6	3	Screws
7	3	Washers
8	1	Ftg Strain Relief
9	1	Ftg Strain Relief
10	2 ft	Conduit
11	1	Coil
12	2	Fitting
13	1	Strain relief
14	1	Power Cord

Fig. 9 Hydraulic Power Unit
Single Phase , 115V

Description

Pump Capacity: .85 GPM

Motor: 1.5 HP @ 2450 RPM

Down valve: 24-1-60

Power: 115-1-60

Tank Capacity: 1.0 Gallons

Maintenance

All servicing should be done by qualified personnel. Qualified personnel should be able to read and understand wiring and hydraulic diagrams. They should be able to troubleshoot live electrical circuits safely and in accordance with accepted practice. **For safety's sake**, if in doubt, please contact your dealer or Southworth Products Corporation Customer Service Department at (207) 878-0700.

Before servicing the unit, please read and understand all of this section and the section entitled "Operating Instructions."

Greasing Standard Lift Tables: Greasing of bearings in the cylinders must be done at least every 1000 cycles. Other moving parts should be greased when necessary.

Lift Tables with "HD Equipment": Greasing of bearings in the cylinders must be done at least every 1000 cycles. All other places every 2000 cycles.

Oil Control: When checking the oil, please note that the table is in its lowest position and the tank contains max volume of oil. Check for oil leakage.

Safety Equipment: Check the action of the safety frames and the distance around the equipment to eliminate trapping risk.

Overloading: Check for damage due to overloading.

Cables and Hoses: Check to maintain all cables and hoses.

Cleaning: Make sure that signs are clearly visible.

Hydraulic Oil Specifications

If the RollE will be used at normal ambient temperatures, Southworth supplies the unit with Citgo AW 32 oil. This may be replaced by any other good quality oil with 150 SSU at 100° F and rust and oxidation inhibitors and anti-wear properties.

If the RollE will be used at ambient temperatures below 0°F, use aircraft hydraulic oil. Use Type 15 aircraft hydraulic oil.

The following are equivalent to CITGO AW32:

TYPE	MANUFACTURER
DTE 24	EXXON/MOBIL
NUTO H32	EXXON/MOBIL
AMOCO AW32	CHEVRON (AMOCO CO.)

CAUTION!

It is very important to keep the hydraulic oil free of dirt, dust, metal chips, water, and other contamination. Most of the problems with hydraulic systems are caused by contamination in the oil.

Troubleshooting

All servicing should be done by qualified personnel. Qualified personnel should be able to read and understand wiring and hydraulic diagrams. They should be able to troubleshoot live electrical circuits safely and in accordance with accepted practice. **For safety's sake**, if in doubt, please contact Southworth Products Corporation at (207) 878-0700.

Before servicing the unit, read and understand this entire section and the section entitled "Operating Instructions."

IMPORTANT! All motors have a thermal overload protection against overheating as from May 1996. When fault-tracing, first check that the overload cabling is connected (purple cable which should be connected to terminal 18 on the P.C.B.) **NOTE!** When the motor has cooled down it can be started again

If the table does not lift properly:

1. Check motor voltage and fuses. Change the fuse if it is blown.
2. Check direction of rotation of motor. If the motor runs in the wrong direction, change two phases.

WARNING!

It is important that the motor does not run for too long in the wrong direction, the pump can be damaged.

3. The table does not lift max load. Adjust the pressure on the valve. Adjust according to the max load to be lifted.
4. The table does not lift to max. Check the oil level in the tank. Fill up with height and the pump takes in air recommended oil.

The tank should not be filled when table is raised. If necessary, bleed the system for air when connecting the hose.

5. Check for oil leakage. Tighten the hose connections. Change cylinder seals or cylinder.
6. Check the remote power pack. Check the snap coupling between table and power pack

If the table will not lower properly:

1. Check to see if the safety valve is activated. Find out why it has activated, with great caution.
2. Check feed voltage and fuses. Change the fuse if it is blown.
3. Check the function of safety frame. The switches can be affected. Straighten and adjust. When the safety equipment is activated and the circuit broken, the circuit must be activated again by raising the table a little. Adjustment of safety frame.
4. Check adjustment of lowering speed. If the speed is too fast the safety valve can shut down. Adjust the lowering speed (reduce the oil flow).
5. The table leaks down. Clean or change the check valve or down valve.
6. Check the remote power pack. Check the snap coupling between table and power pack.

Ordering Replacement Parts

Southworth has carefully chosen the components in your unit to be the best available for the purpose. Replacement parts should be identical to the original equipment. Southworth will not be responsible for equipment failures resulting from the use of incorrect replacement parts or from unauthorized modifications to the machine.

Southworth can supply all replacement parts for your Southworth lift. With your order, please include the model number and the serial number of the unit. You will find these numbers on the name plate.

To order replacement parts, please call the Parts Department at (207) 878-0700. Parts are shipped subject to the following terms:

- FOB factory.
- Returns only with the approval of our parts department.
- Payment net 30 days (except parts covered by warranty).
- Freight collect (except parts covered by warranty).

Parts replaced under warranty are on a “charge-credit” basis. We will invoice you when we ship the replacement part, then credit you when you return the assumed substandard part.

Parts Department
Southworth Products Corp
P.O. Box 1380
Portland, ME 04104-1380
Telephone: (207) 878-0700
FAX: (207) 797-4734
repairparts@SouthworthProducts.com

RETURN MATERIALS AUTHORIZATION (RMA) PROCEDURES

The Southworth Return Authorization (RMA) Procedure is provided as a courtesy to our customers in the event a product or a component may need to be returned.

If a customer wishes to return a Southworth product, the first step in the process is to request an RMA number from the Customer Service Department. This request must be made on or before the thirtieth (30th) calendar day following the date of Southworth's invoice for the merchandise being returned.

The RMA number must appear on the outside of any packaging material for a return to be accepted and processed at Southworth manufacturing facility. Customers shipping returns back to Southworth, from the continental US, Canada or Mexico have thirty (30) days from the effective date of the RMA to have the merchandise arrive freight prepaid at Southworth. If the RMA number is missing or expired (beyond 30 days) it may be refused at Southworth. If any RMA is expired, contact the Customer Service Department before returning to Southworth.

All RMA's are subject to the appropriate restocking fees. All credits issued are less restocking fees as applicable, plus any assessed outbound/inbound in-transit damages.

Return addresses: please refer to your RMA for the specific address to which your product should be returned. Southworth has multiple facilities and returning goods to other than the designated location will result in goods being refused.

Please contact the Customer Service Department at anytime regarding questions to this procedure.

Southworth Products Corp
P.O. Box 1380
Portland, Maine 04104
PH: 1-800-743-1000 or 1-207-878-0700 FAX: 207-797-4734
www.SouthworthProducts.com

2 YEAR WARRANTY

Southworth Products Corp warrants this product to be free from defects in material or workmanship for a period of *two (2) years* of single shift usage from date of shipment, providing claim is made in writing within that time period. This warranty shall not cover modified designs for special applications, failure or defective operation caused by misuse, misapplication, negligence or accident, exceeding recommended capacities, failure to perform required maintenance or altering or repairing, unless alteration is authorized by Southworth Products Corp. Except as set forth herein, there are no other warranties, express or implied, including the warranties of merchantability and fitness for a particular purpose, all of which are hereby excluded.

Southworth Products Corp makes no warranty or representation with respect to the compliance of any product with state or local safety or product standard codes, and any failure to comply with such codes shall not be considered a defect of material or workmanship under this warranty. Southworth Products Corp shall not be liable for any direct or consequential damages arising out of such noncompliance.

Southworth Products Corp's obligation under this warranty is limited to the replacement or repair of defective components at its factory or another location at Southworth Products Corp's discretion. This is buyer's sole remedy. Except as stated herein, Southworth Products Corp will not be liable for any loss, injury or damage to persons or property, nor for direct, indirect, or consequential damage of any kind, resulting from failure or defective operation of said product.

This warranty may be altered only in writing by Southworth Products Corp, Portland, Maine.

SOUTHWORTH
We'll Show You How

SOUTHWORTH PRODUCTS CORP
P.O. Box 1380, Portland, ME 04104-1380
Telephone: 800-743-1000 • 207-878-0700
Fax: 207-797-4734
www.SouthworthProducts.com