

OWNER'S MANUAL

PalletPal™ Stretchwrapper

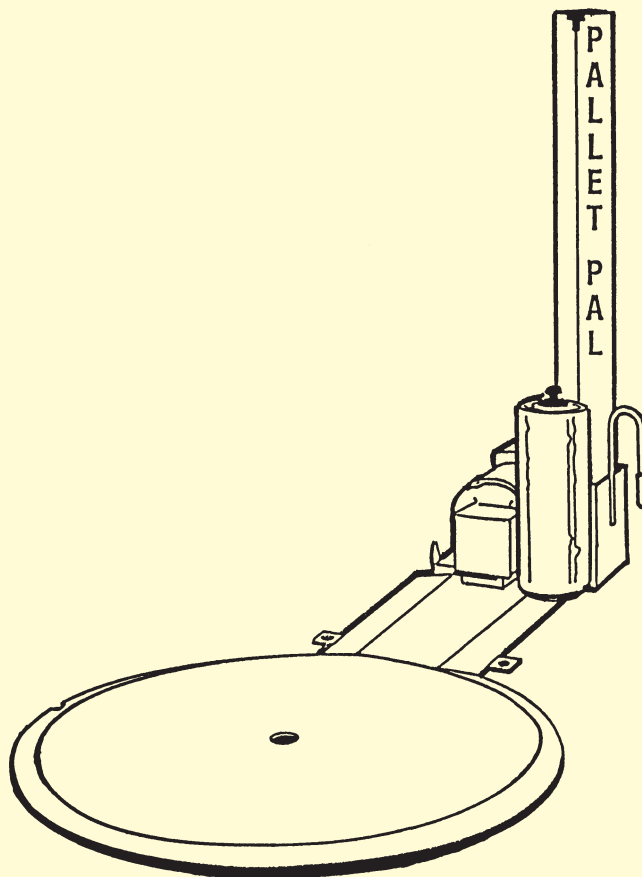

Model # _____

Serial # _____

Placed in Service _____

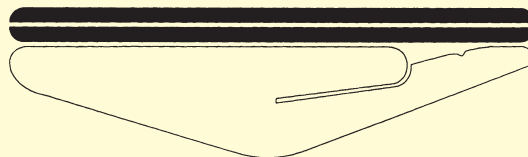

SOUTHWORTH

Southworth Products Corp

P.O. Box 1380, Portland, Maine 04104-1380

Phone: 207-878-0700 Fax: 207-797-4734

September 2005

INTRODUCTION

The PalletPal™ Stretchwrapper is an industrial-grade powered-turntable stretchwrapper. The unit improves productivity and reduces worker fatigue and injury. It also produces tighter, more secure wraps. The PalletPal™ Stretchwrapper unit saves film, and uses less expensive film than hand wrappers.

This manual contains information to help you to learn about the safe and proper installation, use and upkeep of your PalletPal™ Stretchwrapper. Please be sure that this manual is available to anyone who uses or services the stretchwrapper. Be sure that everyone who uses the stretchwrapper has read this manual.

The PalletPal™ Stretchwrapper units may be used in a wide variety of industrial settings. The instructions included in this manual are not necessarily all-inclusive, because Southworth cannot anticipate all conceivable or unique situations.

In the interest of safety, please read this whole manual carefully. Please understand the material in the manual before you install, use, or service the Stretchwrapper unit. If you have any questions about the instructions in this manual, please contact your dealer or Southworth Products Corp.

Southworth's product warranty is shown on the rear cover of this manual. This instruction manual is **not intended to be or to create any other warranty, express or implied, including any implied warranty of merchantability or fitness for a particular purpose, all of which are hereby expressly excluded.** As set forth more specifically in the product warranty, Southworth's obligation under that warranty is **limited** to the repair or replacement of defective components, which shall be the buyer's **sole remedy**, and Southworth shall not be liable for any loss, injury, or damage to persons or property, nor for any direct, indirect, or consequential damage of any kind resulting from the PalletPal™ Stretchwrapper unit.

TABLE OF CONTENTS

INTRODUCTION	2
SAFETY	4
Operation Notes	4
Installation Notes	5
Maintenance Notes	6
Safety Labels	6
SPECIFICATIONS	6
INSTALLATION INSTRUCTIONS	7
Unpacking the Lift	7
Assembly	7
Anchoring the Unit	8
Electrical Connections	8
Testing	8
OPERATING INSTRUCTIONS	8
Operation Notes	8
Loading Film	9
Wrapping Film	9
Stopping the Machine	9
MAINTENANCE	10
Routine Periodic Maintenance	10
Adjusting the Belt Tension	10
Removing the Turntable	10
Inspecting and Lubricating the Turntable	11
Changing the Drive Belt	11
TROUBLESHOOTING	12
ORDERING REPLACEMENT PARTS	12
Film Roll Tensioning Parts	13
Parts Listing	14
WARRANTY	16

LIST OF FIGURES

Fig. 1	PalletPal Stretchwrapper	5
Fig. 2	Wiring Diagram	15

SAFETY

The Stretchwrapper unit has been carefully designed to be as safe as possible for operators and service workers. If you take a few common-sense precautions, you will be able to use the machine safely. However, the Stretchwrapper unit is a powerful machine with moving parts, and is capable of causing personal injury if proper precautions are not taken.

Therefore, throughout this manual, Southworth has identified certain hazards, which may occur in the use and servicing of the Stretchwrapper unit, and provided appropriate instructions or precautions, which should be taken to avoid these hazards. In some cases, Southworth has also pointed out the consequences, which may occur if Southworth's instructions or precautions are not followed. Southworth uses the following system of identifying the severity of the hazards associated with its products:

Danger!

Immediate hazard which will result in severe personal injury or death.

Warning!

Hazard or unsafe practice which could result in severe personal injury or death.

Caution!

Hazard or unsafe practices, which could result in minor personal injury or property damage.

Please read and follow this instruction manual, including all safety instructions and precautions, carefully and completely.

OPERATION NOTES

Danger!

The power cord can be damaged or cut by sharp objects. Keep all sharp objects away from the power cord. Don't step on the power cord or drop anything on it. If the power cord is damaged, you may be exposed to 120V

ac electricity. Do not use the machine if the power cord is damaged in any way.

Danger!

Never use this machine if it is wet or under water. This can create a serious electrical shock. Protect the unit from rain and moisture. The machine is not intended to be used in a washdown environment.

Warning!

Never operate the unit if the load is off-center. The load may shift, and you may be injured. This can also damage the machine.

Warning!

Do not try to use this machine with damaged or broken pallets. Broken pallets may have boards or nails, which hang down below the main part of the pallet. As the pallet is turned, these boards or nails may catch on the belt guard. See Fig. 1. This can cause the pallet to stop turning suddenly, and this can cause the load to shift. You may be injured, and the machine may be damaged. Boards or nails may extend up to 1/8 inch below the bottom of the pallet. If necessary, you can raise the bottom of the pallet by placing spacers on the turntable. Use pieces of 2" x 4" lumber, about 36" long. Don't use small blocks to support the pallets - these may not be stable when the load begins turning.

Warning!

Do not use the machine with a pallet which is larger than 50" x 50". If you try to use a larger pallet, a corner of the pallet may hit one of the fixed parts of the machine. This can cause the pallet or the load to shift. You may be injured, and the machine may be damaged.

Warning!

Do not drop the load on the turntable. If you do this while the turntable is moving, the load may shift. You may be injured, or the machine may be damaged. If you drop the load while the turntable is stopped, the machine may be damaged.

Warning!

Keep the area around machine clean. Do not allow any dirt, debris, spilled oil, or excess

grease to collect. These materials may cause you to slip while the machine is operating, and you may be injured.

Warning!

Stay clear of the turntable when it is moving. As the pallet turns, a part of the load may rotate around and hit you. Never operate the unit when anyone is standing on the turntable. The person on the turntable may be thrown off and injured.

Caution!

Keep the film carriage in the latched (lower) position when the machine is unattended or not in use.

Caution!

Do not use this unit with a load greater than 2500 lbs. This includes the weight of the payload and the weight of the pallet. If you overload the machine, it may be damaged.

Caution!

This machine is designed for light commercial duty. Do not use the unit to process more than 20 pallets per day. If you try to use the machine more often, or try to use the machine continuously, the machine may be damaged. The motor may overheat, and other parts may wear quickly.

INSTALLATION NOTES

Danger!

The electric motor used in the unit can create sparks. Don't use the unit in an area where flammable gases may be present.

Warning!

The unit is attached to the skid using metal bands. These bands are under high tension. The edges are sharp. Wear safety glasses and gloves when you handle or cut the banding.

Warning!

Do not use the machine without tightening the bolts, which hold the tower and film carriage assembly. See Fig. 1. If you do not do this, the tower may fall when you try to raise the film carriage. You may be injured, or the machine may be damaged.

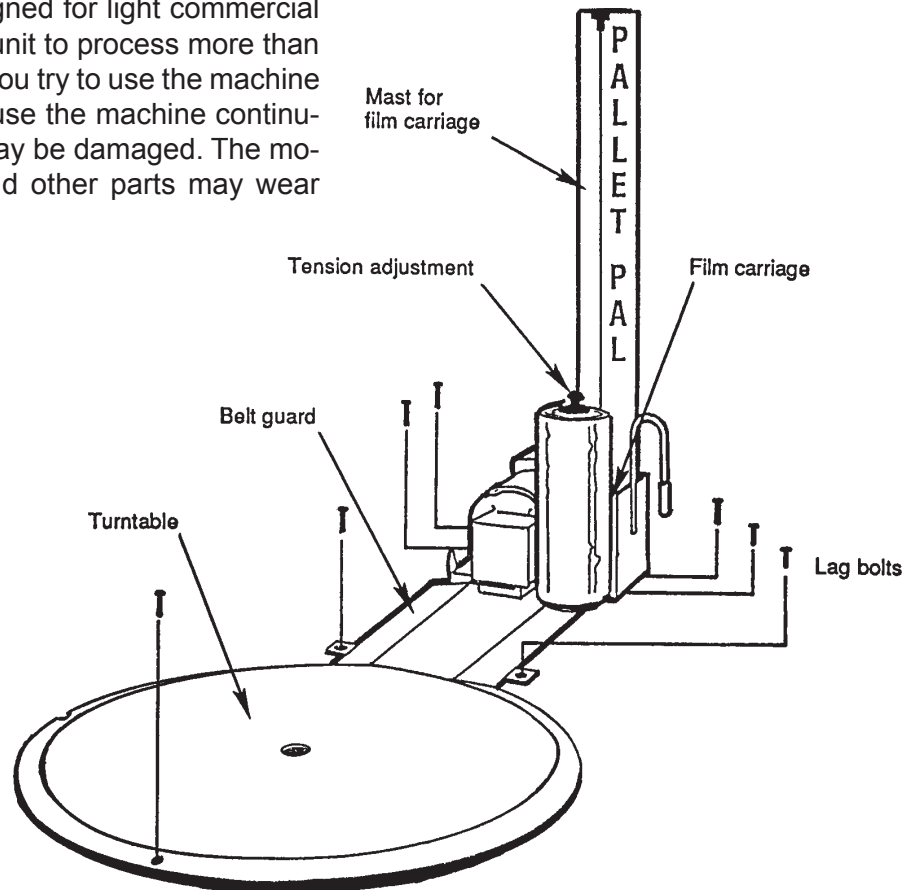

Fig. 1
PalletPal Stretchwrapper

Caution!

When removing the unit from the shipping pallet, be very careful to support the section of the machine where the drive belt housing meets the turntable disk. This is the weakest point, yet it is very important to the function of the machine.

Caution!

During installation, do not tilt the unit more than 30 degrees or drop it. This can cause the balls in the carrier plate to become unseated. The machine may be damaged when you start the unit.

Caution!

The unit must be installed on a smooth flat surface. If the floor is not flat, this can create stresses in the base of the machine. The machine may not work properly, or parts of the machine may wear more quickly than they should.

Caution!

Do not use the machine unless it has been firmly anchored to the floor. If you do not do this, the machine may move as it operates. This can create stresses, which may damage the machine.

Caution!

Be sure the film carriage is latched in position at the bottom of the tower before you remove the tower from the pallet. If you do not do this, the carriage may slide as you remove the pallet.

Caution!

Do not move the machine once you have attached the tower. If you must move the machine, disassemble the tower first. If you strike the tower while moving the machine, it is very easy to damage the machine.

MAINTENANCE NOTES

Danger!

This machine contains electrical parts which carry 120V ac. If you touch an exposed part while it is charged, you may be killed or injured. Do not work on the machine unless you are a

trained electrician or electrical technician. Always disconnect the power before you service the machine. (Remember to do this if you lubricate the machine.)

SAFETY LABELS

When it is shipped from the factory, the machine includes the following safety labels. Be sure all of these labels are in place. Never paint over the labels. Replacements are available from Southworth.

- A series of labels around the turntable indicating that workers should not stand on the turntable.
- A label on the belt guard: "Maximum capacity 2500 lbs."
- Two labels on the sides of the belt guard: "Warning - Machine must be lagged down to a flat surface."

SPECIFICATIONS

Load capacity: 2500 lbs. uniform load

Load size: 50" wide x
50" long x 65" high

Power: 115V ac, 10, 60Hz, 6 amp

Film capacity: 10" dia. x 12"
to 20" long 90-1/2" long

Length overall: 90-1/2"

Height of mast: 60-3/8"

**Height
(film carriage
raised, 20" film):** 66-3/4"

**Turntable
ramp dia:** 49-7/16"

**Turntable
diameter:** 43 3/8"

Turntable height: 1"

Speed: 8.25 rpm

Controls: Footswitch,
momentary contact

Net weight: Approximately 600 lbs.

INSTALLATION INSTRUCTIONS

Unpacking the Lift

The PalletPal Stretchwrapper unit has been pre-wired and pre-assembled. It was tested to factory specifications before shipment.

1. Before you start to install the unit, check for local codes and ordinances, which may apply. It is your responsibility to obtain any necessary permits.
2. Please read all- of these instructions carefully. Be sure to read and understand all of the warnings.
3. Inspect the shipping crate carefully for any damage that may have affected the machine. If you see signs of damage, tell the trucker. Also make a note of this on the shipping papers which you are asked to sign.
4. Choose the place where you want to mount the unit. It is extremely important that the PalletPal Stretchwrapper be set up on a smooth and flat surface. Check the floor surface carefully and make sure that it is free of all loose debris and dirt. **Danger!** The electric motor used in the unit can create sparks. Don't use the unit in an area where flammable gases may be present.
5. Position the crate beside the point where the machine will be set up. **Warning!** The unit is attached to the skid using metal bands. These bands are under high tension. The edges are sharp. Wear safety glasses and gloves when you handle or cut the banding.
6. Remove the metal banding which secures the machine to the pallet. Remove all packing material.
7. Remove the tower and set it aside. **Caution!** Be sure the film carriage is latched in position at the bottom of the tower before you remove the tower from the pallet. If you do not do this, the carriage may slide as you remove the pallet.
8. Carefully remove the turntable assembly and place it in the center of the setup area. Slide the disk and drive belt assembly onto the floor. The best way to do this is to make a ramp to the floor, using steel or wood lengths. Slowly slide the disk and drive belt to the floor using this ramp.

Caution!

When removing the unit from the shipping pallet, be very careful to support the section of the machine where the drive belt housing meets the turntable disk. This is the weakest point, yet it is very important to the function of the machine.

Caution!

During installation, do not tilt the unit more than 30 degrees or drop it. This can cause the balls in the carrier plate to become unseated. The machine may be damaged when you start the unit.

Caution!

The unit must be installed on a smooth flat surface. If the floor is not flat, this can create stresses in the base of the machine. The machine may not work properly, or parts of the machine may wear more quickly than they should.

9. Remove the remaining components and lay them out on the floor.
10. If you have any questions about the steps in the installation process, please call Southworth Customer Service at 1-800-743-1000.

Assembly

1. Install the tower and carriage assembly. Remove the nuts and washers from the four studs on the tower mounting plate.
2. Lift the tower and carriage assembly and position it above the motor and tower mounting plate. **Warning!** The tower and carriage assembly weighs about 120 lbs. To prevent back injury, get a helper to assist with this assembly. Bend your knees, and keep your back straight as you lift.
3. Align the four holes in the tower base plate with the studs on the mounting plate. Lower the tower and carriage assembly onto the mounting plate.
4. Install and tighten the washers and nuts.

Warning!

Do not use the machine without tightening the bolts that hold the tower and film carriage assembly. If you do not do this, the tower may fall

when you try to raise the film carriage. You may be injured, or the machine may be damaged.

Caution!

Do not move the machine once you have attached the tower. If you must move the machine, disassemble the tower first. If you strike the tower while moving the machine, it is very easy to damage the machine.

Anchoring the Unit

Once the tower has been attached, the machine must be anchored before you use it. The machine has holes for 7 lag bolts. See Fig. 1.

Caution!

Do not use the machine unless it has been firmly anchored to the floor. If you do not do this, the machine may move as it operates. This can create stresses, which may damage the machine.

Electrical Connections

Plug the power cord directly into a 115V AC outlet. Do not use an extension cord. When possible, use a dedicated service to provide power to the machine. This eliminates voltage drops, which may cause the machine to work erratically. The power source should have a 15-amp fuse or circuit breaker.

Testing

1. Press the footswitch. The turntable should begin to rotate in a clockwise direction.
2. Grip the handle on the film carriage. Raise and lower the carriage. It should travel up and down the tower with little resistance.

OPERATING INSTRUCTIONS

Operation Notes

1. Do not use this unit with a load greater than 2500 lbs. This includes the weight of the payload and the weight of the pallet. If you overload the machine, it may be damaged.
2. This machine is designed for light commercial

duty. Do not use the unit to process more than 20 pallets per day. If you try to use the machine more often, or try to use the machine continuously, the machine may be damaged. The motor may overheat, and other parts may wear quickly.

3. Do not use the machine with a pallet which is larger than 50" x 50". If you try to use a larger pallet, a corner of the pallet may hit one of the fixed parts of the machine. This can cause the pallet or the load to shift. You may be injured, and the machine may be damaged.
4. Do not try to use this machine with damaged or broken pallets. Broken pallets may have boards or nails that hang down below the main part of the pallet. As the pallet is turned, these boards or nails may catch on the belt guard. See Fig. 1. This can cause the pallet to stop turning suddenly, and this can cause the load to shift. You may be injured, and the machine may be damaged. Boards or nails may extend up to 1/8 inch below the bottom of the pallet. If necessary, you can raise the bottom of the pallet by placing spacers on the turntable. Use pieces of 2" x 4" lumber, about 36" long. Don't use small blocks to support the pallets - these may not be stable when the load begins turning.
5. The power cord can be damaged or cut by sharp objects. Keep all sharp objects away from the power cord. Don't step on the power cord or drop anything on it. If the power cord is damaged, you may be exposed to 120V ac electricity. Do not use the machine if the power cord is damaged in any way.
6. Never use this machine if it is wet or under water. This can create a serious electrical shock. Protect the unit from rain and moisture. The machine is not intended to be used in a washdown environment.
7. Do not drop the load on the turntable. If you do this while the turntable is moving, the load may shift. You may be injured, or the machine may be damaged. If you drop the load while the turntable is stopped, the machine may be damaged.
8. Keep the area around machine clean. Do not allow any dirt, debris, spilled oil, or ex-

cess grease to collect. These materials may cause you to slip while the machine is operating, and you may be injured.

9. 9. Stay clear of the turntable when it is moving. As the pallet turns, a part of the load may rotate around and hit you. Never operate the unit when anyone is standing on the turntable. The person on the turntable may be thrown off and injured.
10. 10. Keep the film carriage in the latched (lower) position when the machine is unattended or not in use.

Loading Film

1. Loosen the hand knob near the top of the film carriage. Remove the upper saddle core from the shaft in the center of the carriage.
2. Place the roll of film over the shaft. The new roll may be up to 20 inches wide. As you look down on the roll of film, the loose end of the film should be on the left. When you pull film off of the roll, the roll should turn in a clockwise direction.
3. Replace the upper saddle core. Tighten the hand knob to provide the desired film tension.

Wrapping Film

1. Place a pallet on the turntable. The unit is designed with a low clearance so it can be loaded by a pallet jack. Place the center of the load over the center of the turntable.

Warning!

Never operate the unit if the load is off-center. As the turntable moves, the load may shift, and you may be injured. This can also damage the machine.

Warning!

Do not drop the load on the turntable. If you do this while the turntable is moving, the load may shift. You may be injured, or the machine may be damaged. If you drop the load while the turntable is stopped, the machine may be damaged.

2. Walk halfway around the load and attach one end of the film to the side of the load.
3. Press the footswitch to start the turntable

rotation. Some pallets tend to sag a bit at the corners. The corners may hit the sides of the belt cover. See Fig. 1. If the corners hit, stop the machine and place blocks under the pallet to raise it.

Warning!

Stay clear of the turntable while it is moving. As the pallet turns, a part of the load may rotate around and hit you. Never operate the unit when anyone is standing on the turntable. The person on the turntable may be thrown off and injured.

4. Grasp the handle on the film carriage. As the turntable turns, raise and lower the film carriage to wrap different parts of the load. The amount of overlap between pieces of film is determined by how fast you raise and lower the carriage.
5. The knob on top of the film carriage is used to adjust the film tension. If the film breaks or stretches, the tension is too high. Reduce the tension by turning the knob counterclockwise.

Warning!

If the load is very light and there is too much tension on the film, the load can be pulled off of the pallet. The load may be damaged, and you may be injured.

6. When the load has been wrapped, lower the film carriage. Be sure the latch is engaged to hold the carriage in position.
7. Cut the film. Attach the trailing edge of the film to the load.
8. Remove the pallet with the wrapped load.

Stopping the Machine

1. To stop the machine, remove your foot from the footswitch.
2. 2. When the machine is unattended or not in use, lower the film carriage into the latched position.

MAINTENANCE

Danger!

This machine contains electrical parts which carry 120V ac. If you touch an exposed part while it is charged, you may be killed or injured. Do not work on the machine unless you are a trained electrician or electrical technician. Always disconnect the power before you service the machine. (Remember to do this if you lubricate the machine.)

ROUTINE PERIODIC MAINTENANCE

After the first 100 hours of operation –

- Inspect the machine carefully. Tighten any loose nuts, screws, set screws, sprocket keys, etc. Do not change the oil in the gear drive.
- It is normal to see some wear on the plates under the turntable. After a short “break-in” period, this wear should be reduced.

At the start of each shift –

- Make a general walk-around inspection. Remove any dirt and debris from the machine.
- Check for loose or damaged components and wiring.
- Check the condition of the power cord. Don't use the unit if the power cord is damaged.

Every month –

- Remove the belt cover and check the condition of the belt. The driving surfaces of the belt should be smooth, but not hard and shiny or cracked. If the belt is worn or damaged, replace it.
- Check the belt tension. Press on one section of the belt in the middle of its run. If you can deflect the belt more than 1/2 inch, tighten the belt.

Once a year –

Change the oil in the reducer. Use SAE 90 gear oil.

Adjusting the Belt Tension

1. Unplug the machine.
2. Remove the two sheet metal screws that hold the belt cover in place.

3. Loosen the four bolts that hold the motor mounting bracket.
4. The belt adjustment mechanism includes two adjusting bolts with locking nuts. Back off the locking nuts. Turn the adjusting bolts until you have the correct belt tension. Press on one section of belt in the middle of its run. You should be able to deflect the belt about 1/4 inch. Adjust both bolts by the same amount.
5. Re-tighten the locking nuts.
6. Replace the belt cover and re-tighten the sheet metal screws.
7. Plug in the machine.

Removing the Turntable

1. Unplug the machine.
2. Remove the belt guard. Use the two adjusting bolts to release the tension on the drive belt. Remove the belt from the drive pulley under the motor.
3. Use a pair of snap-ring pliers to remove the snap ring in the center of the turntable.
4. Use a lever to lift one edge of the turntable. Start by lifting the edge that is nearest the belt guard.

Warning!

The turntable is very heavy. You will need at least three people to lift this part safely. Be sure to wear heavy gloves when performing this job.

5. Lift the edge of the turntable just a bit so that you can reach the belt. Pull the belt away from the turntable.

Caution!

Be careful to keep the belt away from the grease. If the belt does touch the grease, you must remove the grease before you re-assemble the machine. Use the smallest possible amount of spray degreaser. Degreaser tends to dry out the rubber material in the belt, so use it sparingly.

6. Once the belt is free, you can lift the turntable away from the machine.
7. If necessary, you can now remove the carrier plate. The steel balls used in the machine will re-main in the lower part of the

machine. Don't do this unless you want to degrease the bearings - it can be time-consuming to reassemble this part of the machine.

8. There are 72 balls, 5/8 inch in diameter, in the carrier plate. These are standard chrome-plated steel balls.
9. If you have removed the carrier plate, put it back in position. Place each of the balls in one of the bearings. Be sure that every bearing has a ball. The machine uses the large number of bearings to spread out the weight of the load. If some of the balls are missing, the machine may not work properly, and may wear more quickly.
10. To reassemble the machine, reverse the remaining steps listed above.

Inspecting and Lubricating the Turntable

1. Unplug the machine.
2. Remove the belt guard and release the tension on the drive belt. Remove the belt from the drive pulley under the motor.
3. Remove the turntable as described in the last section.
4. Lift out the carrier plate. Collect the 72 steel balls.
5. Degrease the carrier plate and the steel balls.
6. Inspect the steel balls for signs of wear. Check several balls for discoloration or breakdown of the chrome layer.
7. Set the carrier plate back in position. Place each of the balls in one of the bearings. Be sure that every bearing has a ball. The machine uses the large number of bearings to spread out the weight of the load. If some of the balls are missing, the machine may not work properly, and may wear more quickly.
8. Place a bit of grease inside the opening of each bearing.
9. Work some grease into the bearing at the center of the turntable. The bearings for the V-belt idler rolls are sealed and do not need lubrication.
10. To reassemble the machine, reverse the remaining steps listed above. Guide the belt over

the idler wheels on either side of the belt guard. Be careful not to let the drive belt touch the grease.

Caution!

Be careful to keep the belt away from the grease. If the belt does touch the grease, you must remove the grease before you re-assemble the machine. Use the smallest possible amount of spray degreaser. Degreaser tends to dry out the rubber material in the belt, so use it sparingly.

Changing the Drive Belt

1. Change the belt if it is cracked or dried out, or if the sides of the belt become very shiny. The belt is an A-size V-belt, 183 inches long.
2. Unplug the machine.
3. Remove the belt guard and release the tension on the drive belt. Remove the old belt from the drive pulley under the motor.
4. Remove the turntable as described earlier. Leave the carrier plate in position - do not remove it.
5. Replace the turntable, running the new belt around the base of the part. Be careful not to let the new belt touch the grease here.

Caution!

Be careful to keep the belt away from the grease. If the belt does touch the grease, you must remove the grease before you re-assemble the machine. Use the smallest possible amount of spray degreaser. Degreaser tends to dry out the rubber material in the belt, so use it sparingly.

6. Guide the belt around the two idler pulleys at the end of the belt guard.
7. Guide the belt around the drive pulley under the motor. Tighten the two bolts that set the belt tension. The free play in the center of the belt's run should be about 1/4 inch.
8. Replace the belt guard and plug in the machine.

TROUBLESHOOTING

Troubleshooting Check List

Problem	Possible Cause	Check This
Turntable does not start, motor is dead.	No power to motor.	Check power source, power cord, start switch.
	Drive belt broken or slipping.	Remove belt cover. Check belt condition. Check for correct tension.
Turntable starts slowly.	Drive belt is loose.	Check belt tension and adjust if necessary.
	Drive belt is worn.	Check for shiny surface and cracks. Replace if necessary.
	Grease on drive belt.	Remove belt guard and inspect belt. If belt is contaminated, remove turntable. Degrease turntable and belt.
Excessive “rumble” when unit operates	Wear or lack of lubrication to bearings under turntable.	Remove turntable, inspect, lubricate.
Drive belt wears quickly.	Mounting surface is not flat.	Check for flatness using a level.
Drive motor overheats.	Exceeding duty cycle.	Unit is desinged for 20 pallets per day maximum.
	Unit is overloaded.	Unit is designed for 2500 lb. load including the weight of pallet.

ORDERING REPLACEMENT PARTS

Southworth has carefully chosen the components in your machine to be the best available for the purpose. Replacement parts should be identical to the original equipment. Southworth will not be responsible for equipment failures resulting from the use of incorrect replacement parts or from unauthorized modifications to the machine.

Southworth can supply all replacement parts for your PalletPal Stretchwrapper. With your order, please include the model number and the serial number of the machine. You can find these numbers on the nameplate. This plate is mounted between the motor and the mast.

To order replacement parts, please call the Parts Department. Parts are shipped subject to the following terms:

- FOB factory
- Returns only with the approval of our parts department.
- Payment net 30 days (except parts covered by warranty).
- Freight collect (except parts covered by warranty).

Parts replaced under warranty are on a “charge-credit” basis. We will invoice you when we ship the replacement part, then credit you when you return the worn or damaged part.

PARTS DEPARTMENT
 Southworth Products Corp
 11 Gray Road
 Falmouth, ME 04105
 Telephone: (207) 878-0700 / (800) 743-1000
 Fax: (207) 797-4734

STRETCHWRAPPER
Film Roll Tensioning Parts

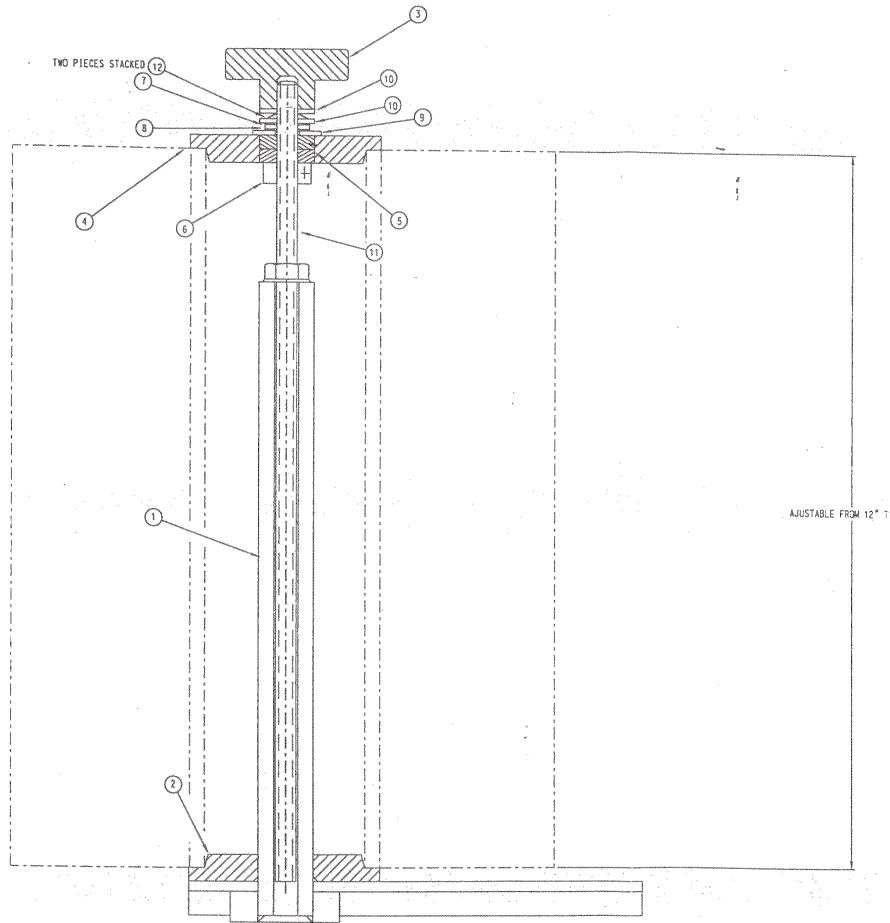

ITEM NO.	PART DESCRIPTION	PART NO.
3	KNOB	2980126
4	CORE MOUNT PIVOT	2980127
5	BEARING	2980128
6	THREADED COLLAR, 3/8-16	2612321
7	WASHER, .375 ID X .812 OD X .030 THICK	2340599
8	THRUST BEARING	2340700
9	WASHER, 7/16 ID X 1 1/4 OD X 5/64 THICK	2340217
10	WASHER, 3/8 ID X 13/16 OD X 1/16 THICK	2340701
12	CURVED SPRING WASHER	2760065

PARTS LISTING

PART	LOCATION	PART NO.	QTY
Axle	Top of film carriage	A-2980222	4
Ball bearing 5/8" dia.	Under turntable, outer ring	6521304	72
Bearing	Center of turntable	6521306	1
Bearing	V-belt idler roller	2332296	2
Bearing	Center of core mount	A-2980128	2
Bearing holder (both size balls)	Under turntable	A-2980213	72
Cable assembly	Film carriage	A-2980072	1
Carrier plate	Under turntable	B-2980212	1
Collar	Below core mount	2612321	1
Core mount	Center of film carriage	A-2980127	1
Drive belt	Around turntable	2612320	1
Drive pulley	Under reducer	A-298015B	1
Gear reducer	End of motor	2281126	1
Handle grip	Film carriage	2381046	1
Idler roller for V-belt	Under belt guard	A-2980113	2
Motor 1/3 HP	Near film carriage	2265491	1
Retaining ring	Center of turntable	2881155	1
Roller	Top of film carriage	A-2980221	1
Seal brush	Under turntable	A-2980774	1
Seal brush holder	Under turntable	A-2980074	1
Sheave	Film carriage cable	2660093	1
Spacing washer	Under turntable bearing	2820199	1
Tab washer	Above turntable bearing	2341453	1
Tensioning knob	Film carriage	A-2980126	1
Thrust bearing	Below film core mount	2340700	1
Washer	Under film tension handle	2340701	1
Washer	Smaller, under film tension handle	2340599	2
Washer	Above film core	2340217	1

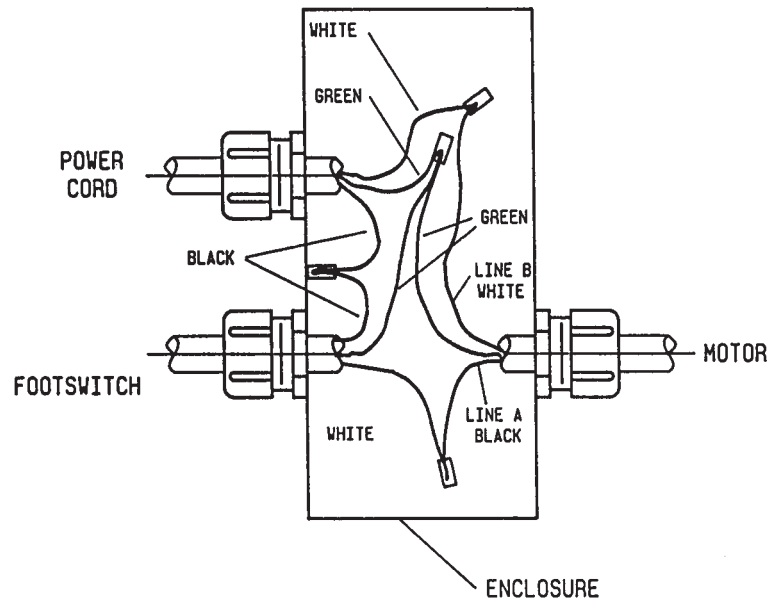

NOTE: ENTRY LOCATIONS MAY DIFFER FROM THOSE SHOWN.
GROUND CONNECTIONS, ALTHOUGH NOT SHOWN, ARE REQUIRED.

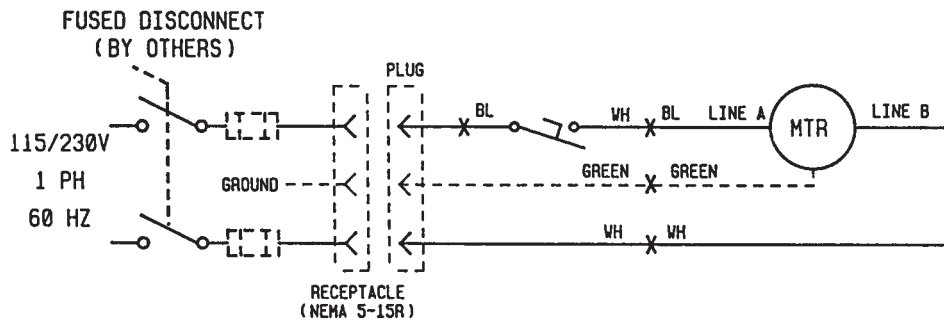

Fig. 2
Wiring diagram

2 YEAR WARRANTY

Southworth Products Corp warrants this product to be free from defects in material or workmanship for a period of *two (2) years* of single shift usage from date of shipment, providing claim is made in writing within that time period. This warranty shall not cover modified designs for special applications, failure or defective operation caused by misuse, misapplication, negligence or accident, exceeding recommended capacities, failure to perform required maintenance or altering or repairing, unless alteration is authorized by Southworth Products Corp. Except as set forth herein, there are no other warranties, express or implied, including the warranties of merchantability and fitness for a particular purpose, all of which are hereby excluded.

Southworth Products Corp makes no warranty or representation with respect to the compliance of any product with state or local safety or product standard codes, and any failure to comply with such codes shall not be considered a defect of material or workmanship under this warranty. Southworth Products Corp shall not be liable for any direct or consequential damages arising out of such noncompliance.

Southworth Products Corp's obligation under this warranty is limited to the replacement or repair of defective components at its factory or another location at Southworth Products Corp's discretion. This is buyer's sole remedy. Except as stated herein, Southworth Products Corp will not be liable for any loss, injury or damage to persons or property, nor for direct, indirect, or consequential damage of any kind, resulting from failure or defective operation of said product.

This warranty may be altered only in writing by Southworth Products Corp, Portland, Maine.



SOUTHWORTH PRODUCTS CORP
P.O. Box 1380, Portland, ME 04104-1380
Telephone: (800) 743-1000 • (207) 878-0700
Fax: (207) 797-4734
www.SouthworthProducts.com