

SOUTHWORTH

**Maintenance Manual
& Operator Instructions**

Pallet Lift Truck

PT-33-M & PT-33-E



Model # _____

Serial # _____

SOUTHWORTH PRODUCTS CORP
P.O. Box 1380 • Portland, ME 04104-1380
Telephone: (207) 878-0700 or (800) 743-1000
Fax: (207) 797-4734

June 2011

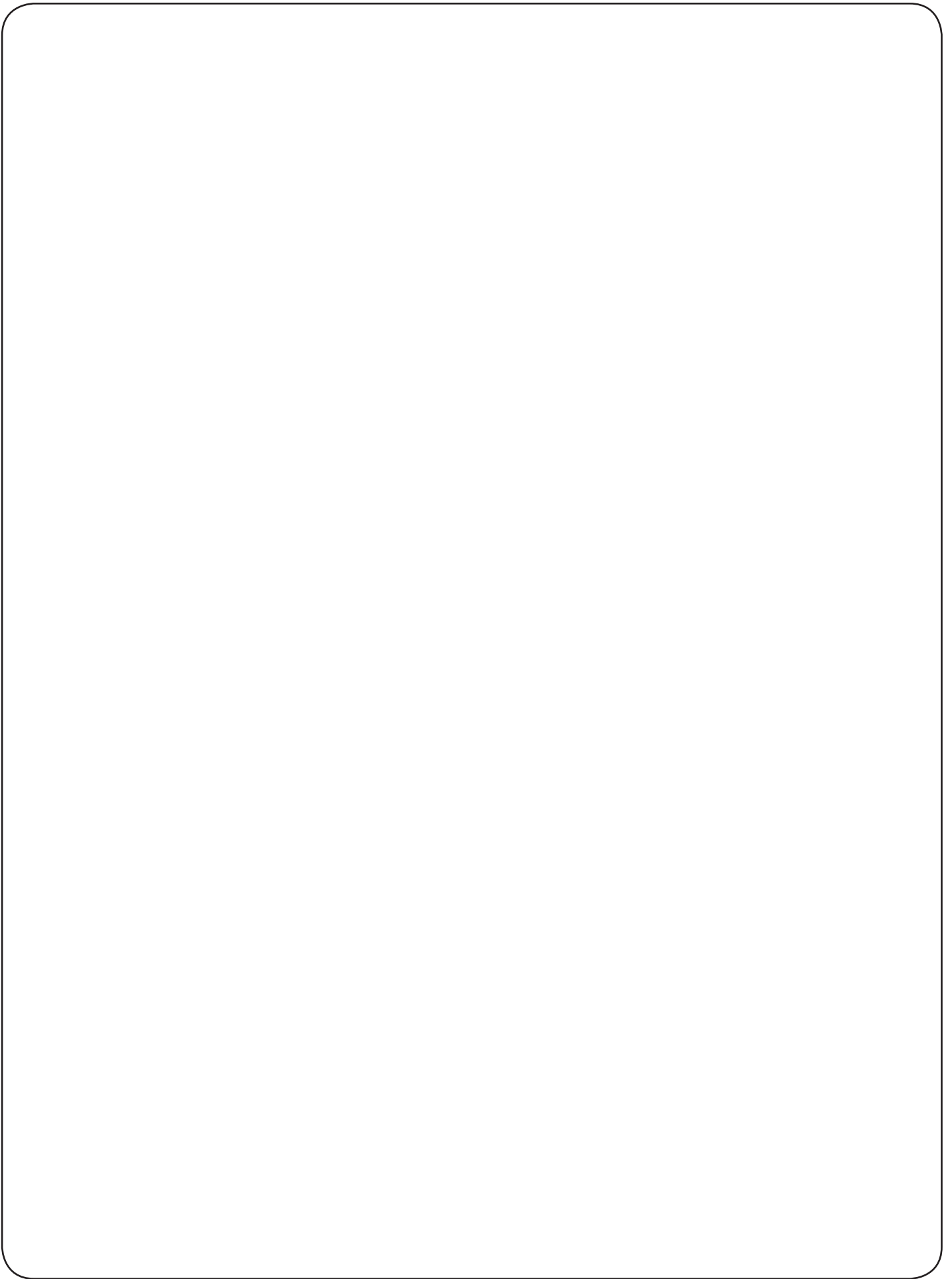

Contents

INTRODUCTION 4

SAFETY 4

 How to operate the Pallet Lift Truck..... 5

 Avoid overloads. Avoid offset loads 6

 Operator precautions..... 7-8

THE BATTERY 9

 Preparing to charge the battery 9

 Precautions for grounding 9

 Battery charging precautions and warnings 10

 Battery maintenance..... 10

ELECTRICAL11

 Fuse replacement11

 Wiring connections 12

LUBRICATION AND HYDRAULIC OIL..... 13

 Oil Change..... 13

CLEANING 14

TROUBLESHOOTING 14

ORDERING REPLACEMENT PARTS 15

2 YEAR WARRANTY Back of Manual

List of Figures

Fig. 1 PT-33-M Chassis components..... 16

Fig. 2 PT-33-M Cylinder & Handle components 18

Fig. 3 PT-33-E Hydraulic pump components 20

Fig. 4 Electrical diagram 20

Fig. 5 PT-33-E Electrical Diagram, Control Current..... 21

Fig. 6 PT-33-E Chassis components 22

Fig. 7 PT-33-E Cylinder..... 24

Fig. 8 PT-33-E Pump chassis 25

Fig. 9 PT-33-E Relay..... 26

Fig. 10 PT-33-E Pump 26

Fig. 11 PT-33-E Handle 27

Fig. 12. PT-33-E Parking brake..... 28

Fig. 13 PT-33-E Top Stop..... 29

Introduction

This manual contains instructions on the safe and proper installation, use, and maintenance of the Southworth Pallet Lift Truck. Be sure that this manual is available to the people who install, use, or service the unit. Be sure that all personnel read this manual before they install, use, or service the unit.

Pallet Lift Truck units may be used in a wide variety of industrial settings. The instructions in this manual are not necessarily all-inclusive, as Southworth cannot anticipate all conceivable or unique situations. *In the interest of safety, please read this whole manual carefully. Please understand the material in this manual before you install, use, or service the Pallet Lift Truck. If you have any questions about any of the instructions in this manual, please contact Southworth Products Corp.*

Southworth's product warranty is shown on page 20 of this manual. This instruction manual is *not intended to be or to create any other warranty, express or implied, including any implied warranty of merchantability or fitness for a particular purpose,*

all of which are hereby expressly excluded. As set forth more specifically in the product warranty, Southworth's obligation under that warranty is limited to the repair or replacement of defective components, which shall be the buyer's sole remedy, and Southworth shall not be liable for any loss, injury, or damage to persons or property, nor for any direct, indirect, or consequential damage of any kind resulting from the Pallet Lift Truck. The Pallet Lift Truck is manufactured in accordance with ANSI Standard B56.10 and PREN 1757-1.

Among the subjects dealt with in this owner's manual are:

- *Proper application*
- *Physical limitations of the product*
- *Risks with improper use*

Please read this Owner's Manual carefully!

Safety

The safety of all persons installing, using, servicing, or working near the Pallet Lift Truck is of paramount concern to Southworth. The Pallet Lift Truck unit is a powerful machine with moving parts, and is capable of causing personal injury if proper precautions are not taken.

Therefore, throughout this manual, Southworth has identified certain hazards which may occur in the use of the Pallet Lift Truck, and provided appropriate instructions or precautions which should be taken to avoid these hazards. In some cases, Southworth has also pointed out the consequences which may occur if Southworth's instructions or precautions are not followed. Southworth uses the following system of identifying the severity of the hazards associated with its products:

DANGER – Immediate hazard which will result in severe personal injury or death.

WARNING – Hazard or unsafe practice which could result in severe personal injury or death.

CAUTION – Hazard or unsafe practice which could result in minor personal injury or property damage.

Please read and follow this instruction manual, including all safety instructions and precautions, carefully and completely.

How to operate the Pallet Lift Truck

PALLET LIFT TRUCK APPLICATION
FOR SKID OR
CONTAINER HANDLING.

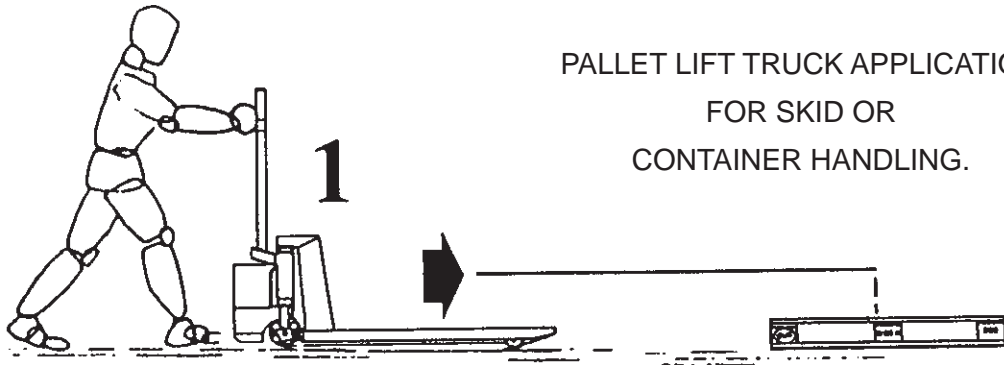

For proper operation,
stand behind the handle.

Push/pull - raise/lower

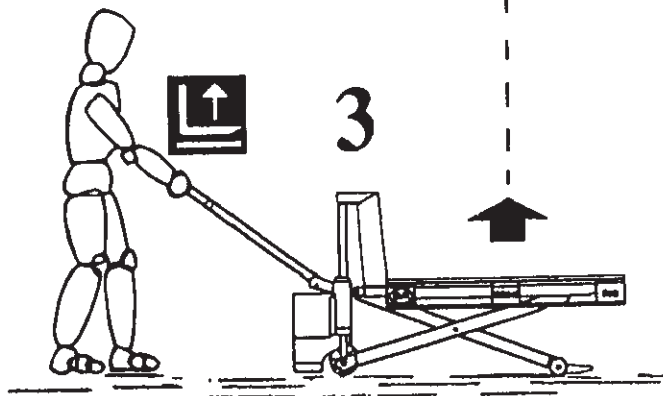
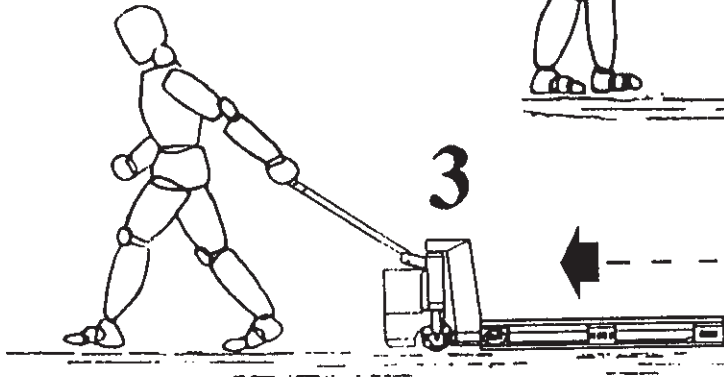
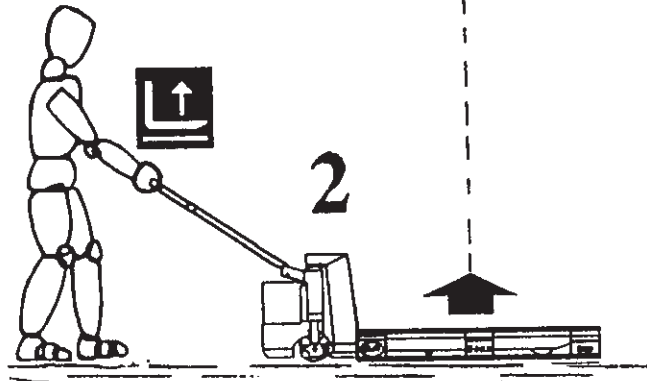

Optimum Safety

Avoid Overloads

The maximum load must not be exceeded. Remember, the Pallet Lift Truck is designed for evenly distributed load - goods on pallet, etc. If the forks are point-loaded on one side, there is risk of bending.

Avoid Offset Loads

The load must be distributed evenly on pallets or similar. The maximum distance between the center of gravity of the load and the face of the mast is illustrated in Figure X. If the distance is exceeded the Pallet Lift truck might tip forward. Goods on pallets, etc. must be properly secured so that they cannot fall off during transport, when the truck is lifted, or when the truck must remain lifted for a time.

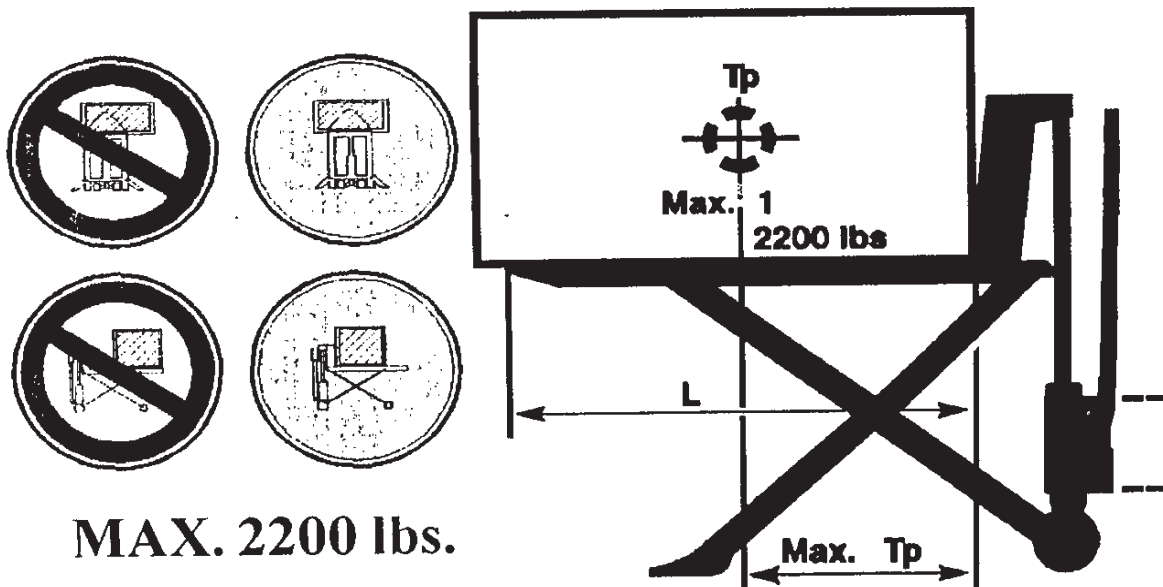

Operator Precautions

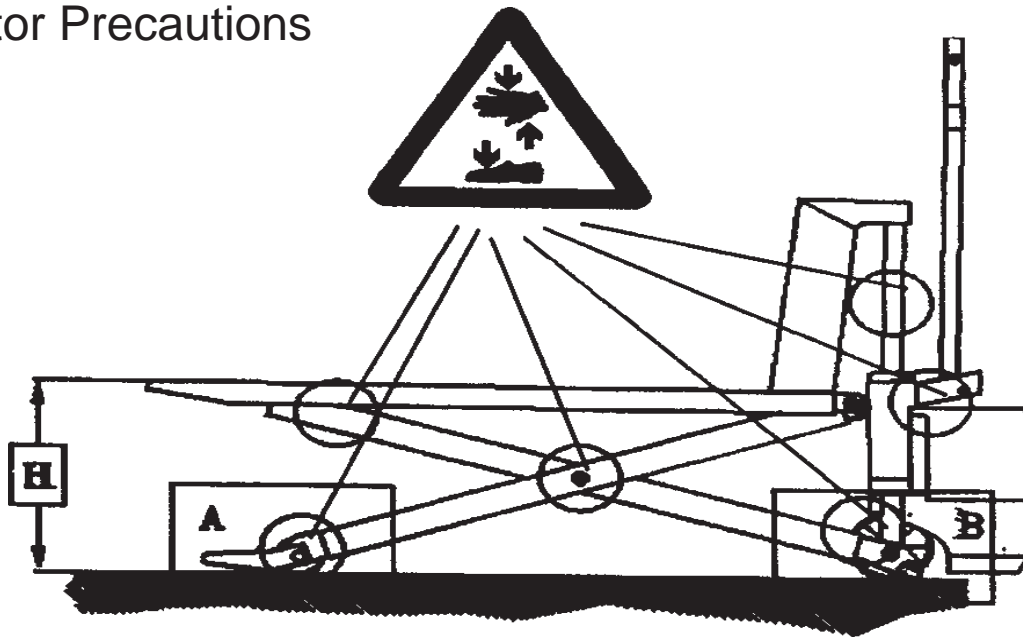

Stability Means Safety

The support pins (B) and thrust shoes (A) together stabilize the truck when raised. It must not be possible to drive the truck when the fork height is more than 16 inches. The support legs are eccentric so that it is possible to adjust them as they wear.

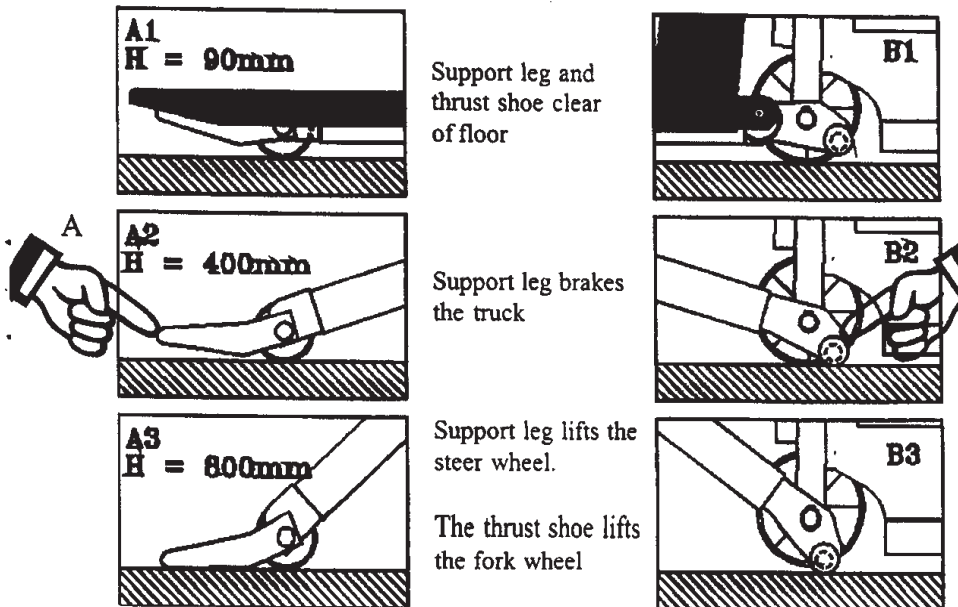

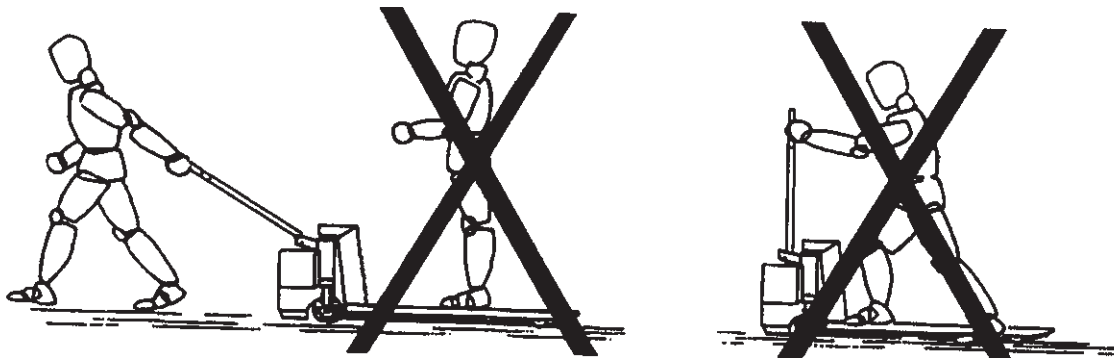

Emergency Braking

If it becomes necessary to use the load as a brake to prevent the Pallet Lift Truck from running loose, activate the DOWN button quickly until the load reaches the ground.

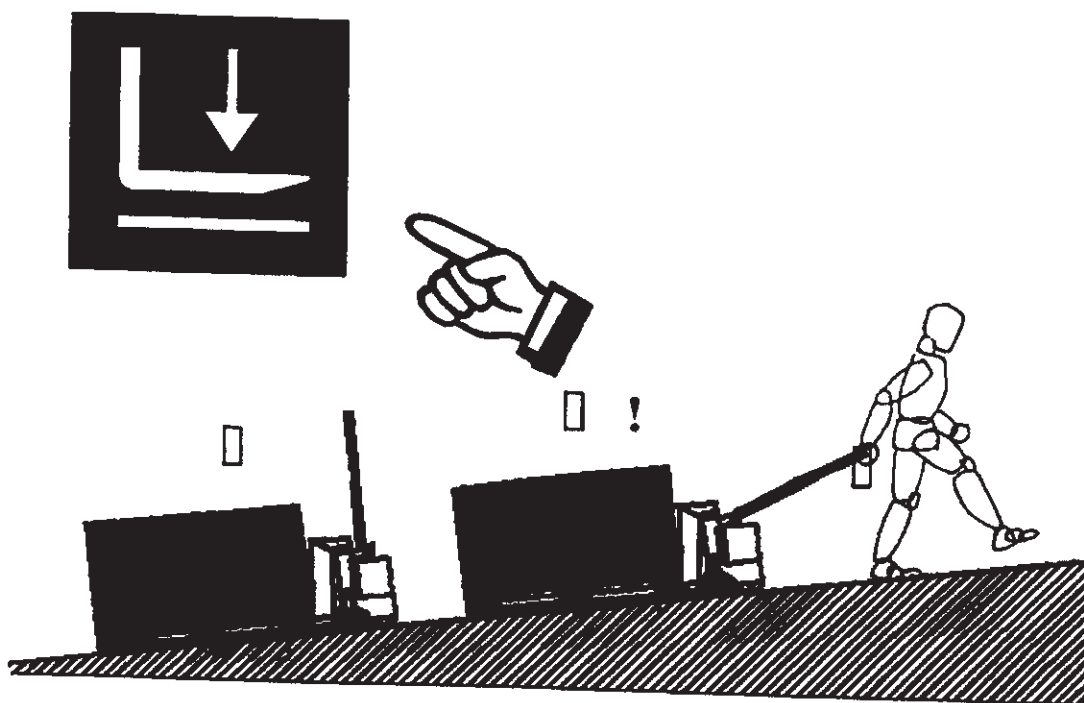

Preparing to charge the battery

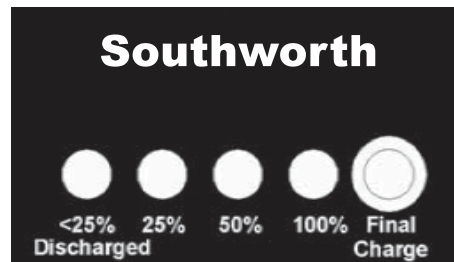

BATTERY INDICATOR

The battery indicator shows the battery charge in %. The most accurate reading can be obtained, when the battery has not been used for 5-10 minutes.

- Red:** Battery capacity: below 25% Discharged
Do not use the product, as the battery can be permanently damaged.
- Green:** Battery capacity: 25% - 100%
The product is ready for use and need not be charged.
- Yellow:** Charging lamp: Is lit during the last part of the charging.
- Final charge:** Indicates full charge

PRECAUTIONS FOR GROUNDING AND AC POWER CORD CONNECTION

Charger should be grounded or have an insulated case to reduce risk of electric shock. If the charger is equipped with an electric cord having an equipment-grounding conductor and grounding plug (three prong plug). The plug must be plugged into an outlet that is properly installed and grounded in accordance with all local codes and ordinances.

DANGER – Never alter the AC cord or plug provided. If it will not fit the outlet, have the proper outlet installed by a qualified electrician. Improper connection can result in a risk of an electric shock.

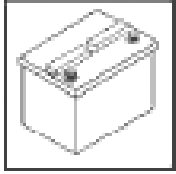

BATTERY CHARGING

Charging must be performed with the charger that is provided and prewired into the machine. During charging, the temperature in the battery must not exceed 120° F. Charging simultaneously with truck operation is not recommended. Plug the charger into a 115V outlet. Charge until the battery gauge indicator lights show fully charged (approximately 6-8 hours).

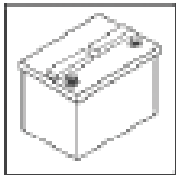

WARNINGS AND INFORMATION ON BATTERY

Avoid the use of open flame batteries. At temperatures around the freezing point, battery capacity is reduced by 30%. The battery terminals, connections and wiring should be clean and free of corrosion. When cleaning any of these components wear a face shield or other suitable protective eyewear.

Read, understand and follow all battery and battery charger manufacturer's specific precautions while working with and/or charging batteries. The battery used in this machine is an AGM (Absorbed Glass Mat) type and allows safe trouble-free performance. There is no need to add electrolyte. No special handling is required and it is classified as non-hazardous.

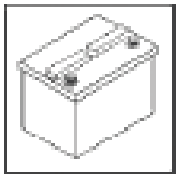

BATTERY MAINTENANCE:

To measure the voltage, use a voltmeter (DC) on the battery poles. The truck must not have been in use for the previous 30 minutes.

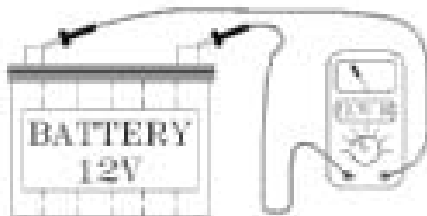

Approx. 12.7 V	Fully charged
Approx. 12.2 V	1/2 charged
Approx. 12.0 V	1/4 charged
Approx. 11.6 V	Discharged

**WARNING: IF THESE INSTRUCTIONS ARE NOT CLEAR
OR IF THERE ARE ANY QUESTIONS,
PLEASE CONTACT SOUTHWORTH PRODUCTS CORP**

Telephone 1-800-743-1000 or Fax 207-797-4734

E-mail: service@SouthworthProducts.com



FUSE REPLACEMENT

There are three fuses in the electrical circuit.

A) 80 amp fuse in main supply from battery.

B) 30 amp fuse for built-in charger.

C) 5 amp fuse in control current circuit.

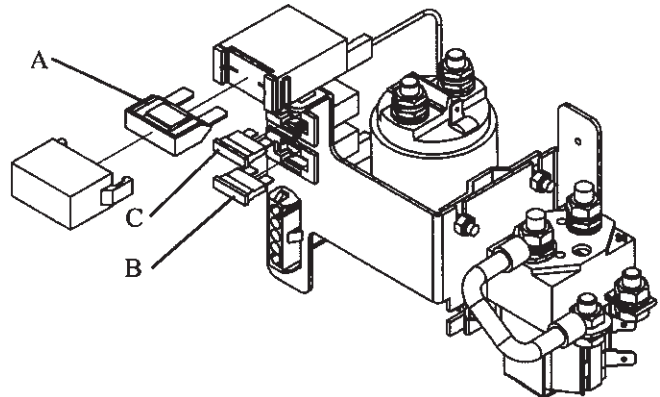

Do not insert a larger fuse. The fuse acts as a protector for the pump motor.

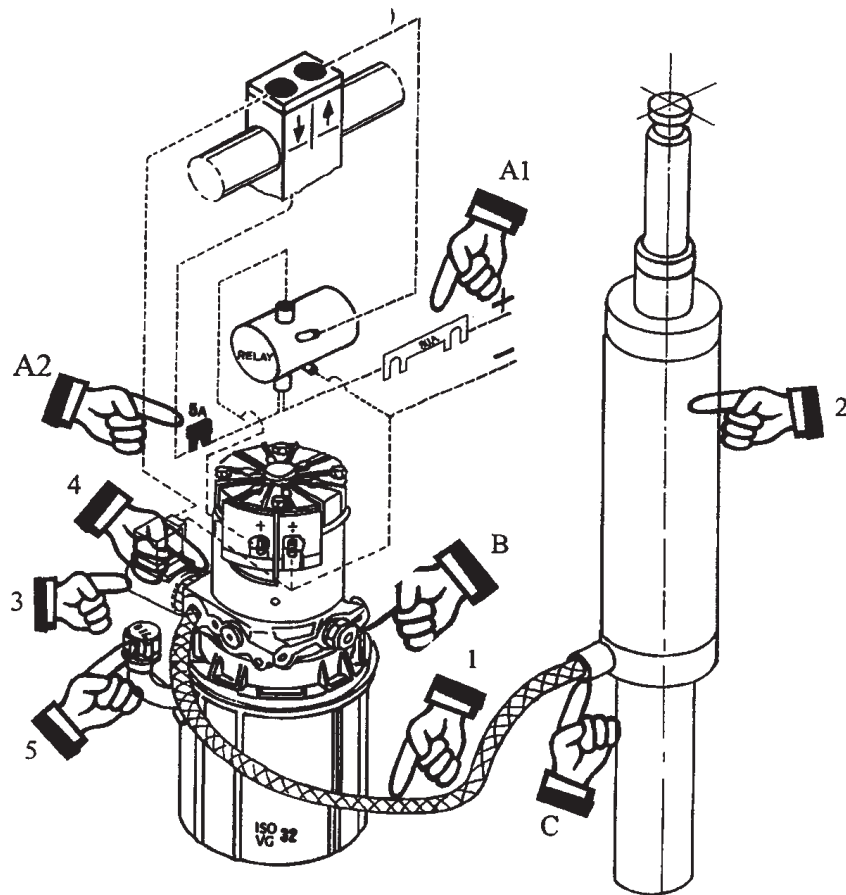

Safety System

A. **Fuses:** Motor protector and protection against electrical overload.

B. **Safety/pressure relief valve:** Protection against mechanical and hydraulic overload. Factory-set for maximum design load (2200 lbs.)

C. **Hose safety valve:** Protection against load "falling" in the event of hose fracture.



WIRING CONNECTIONS

Many operational problems are caused by poor connections in the electrical circuit. Make sure that the connections are clean and tight.

Check connections regularly for damage at insulating caps or bad connections at plugs, etc. Keep all screw/nut connections tight.

Regular inspection and the replacement of worn or defective parts in good time will prolong the life of the Pallet Lift Truck.

“Prevention is better than repair”, therefore ensure:

- Correct usage
- Regular cleaning
- Periodic safety inspection
- Regular adjustment



ADJUSTING FORK HEIGHT

The fork height can be adjusted as follows 3.35“ to 3.66“. The fork height is adjusted by picking out the plug (A).

Adjustment of the fork height (B):

Turning right: The fork height is raised

Turning left: The fork height is lowered

The plug is fastened again (C).

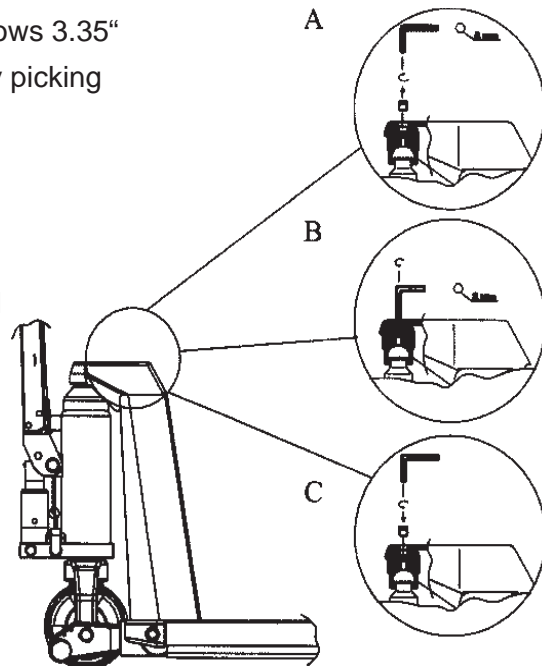



Lubrication and hydraulic oil

Under normal operation conditions the Pallet Lift Truck requires no lubrication.

All ball bearings are sealed and lubricated for life, and moving parts have self-lubricating bearings or are treated with molybdenum disulphide grease.

The hydraulic system is filled with hydraulic oil of viscosity (class ISO VG 32.) non detergent 10W motor oil. An additive is added to the oil: Wynn's Hydraulic Systems Concentrate.

The concentrate reduces friction and wear and protects against corrosion. Pre-mixed hydraulic oil with additive is available from the dealer. The oil is suitable for use in the temperature range 14° to 120° F. A thinner oil is recommended for temperatures lower than 14° F (if necessary, contact your dealer).



Oil change

Draining the oil:

1. Bring the unloaded forks down to the lowest position.
2. Remove the oil tank by taking off the eight (8) clips on the pump and removing the tank.
3. The oil can now be drained and the tank cleaned.

Oil filling:

4. Fill oil through the filling hole on the tank.
5. Oil quantity: 1.5 quarts. Use 10W non-detergent motor oil.
6. Fill oil to the bottom arrow (LogiLift) on the tank.
7. Refit the filling cap and bleed the system.



Bleeding the hydraulic system

With a load of 110 - 220 lbs, the forks must be raised and lowered to top and bottom position 2-3 times.

Cleaning

When cleaning the Pallet Lift Truck, do not direct the water jet onto bearings and seals, as the grease will be washed out and the life of the equipment shortened.

Cleaning of the plastic screen (polycarbonate)

The screen is to be washed with slightly warm water adding a neutral cleaning material, and afterwards washed with clean water. Use a soft sponge, and a soft cotton cloth. Do not use paper towels.

Never use sharp objects or solvent cleaners when cleaning.

Troubleshooting

When the Pallet Lift Truck is used every day, adjustments and the replacement of worn parts might be necessary.

If a fault appears during daily operation of the Pallet Lift Truck first check:

- Oil supply
- Electricity supply
- Condition of leads and fuses

If faults cannot be traced to these sources, contact Southworth Products Corp's Service Department at 800-743-1000.

Ordering Replacement Parts

Southworth has carefully chosen the components in your unit to be the best available for the purpose. Replacement parts should be identical to the original equipment. Southworth will not be responsible for equipment failures resulting from the use of incorrect replacement parts or from unauthorized modifications to the machine.

Southworth can supply all replacement parts for your Southworth Pallet Lift Truck. Key parts are identified in this manual.

With your order, please include the model number and the serial number of the unit. You will find these numbers on the name plate.

To order replacement parts, please call the Parts Department at (207) 878-0700. Parts are shipped subject to the following terms:

F.O.B. factory.

Returns only with the approval of our Parts Department.
Restocking charges may apply.

Payment net 30 days (except parts covered by warranty).

Freight collect (except parts covered by warranty).

Parts replaced under warranty are on a "charge-credit" basis. We will invoice you when we ship the replacement part, then credit you when you return the assumed substandard part.

Parts Department
Southworth Products Corp
PO Box 1380
Portland, ME 04104-1380

Telephone: (207) 878-0700 or 1-800-743-1000

Fax: (207) 797-4734

repairparts@SouthworthProducts.com
www.SouthworthProducts.com

Figure 1 PT-33-M Chassis Components

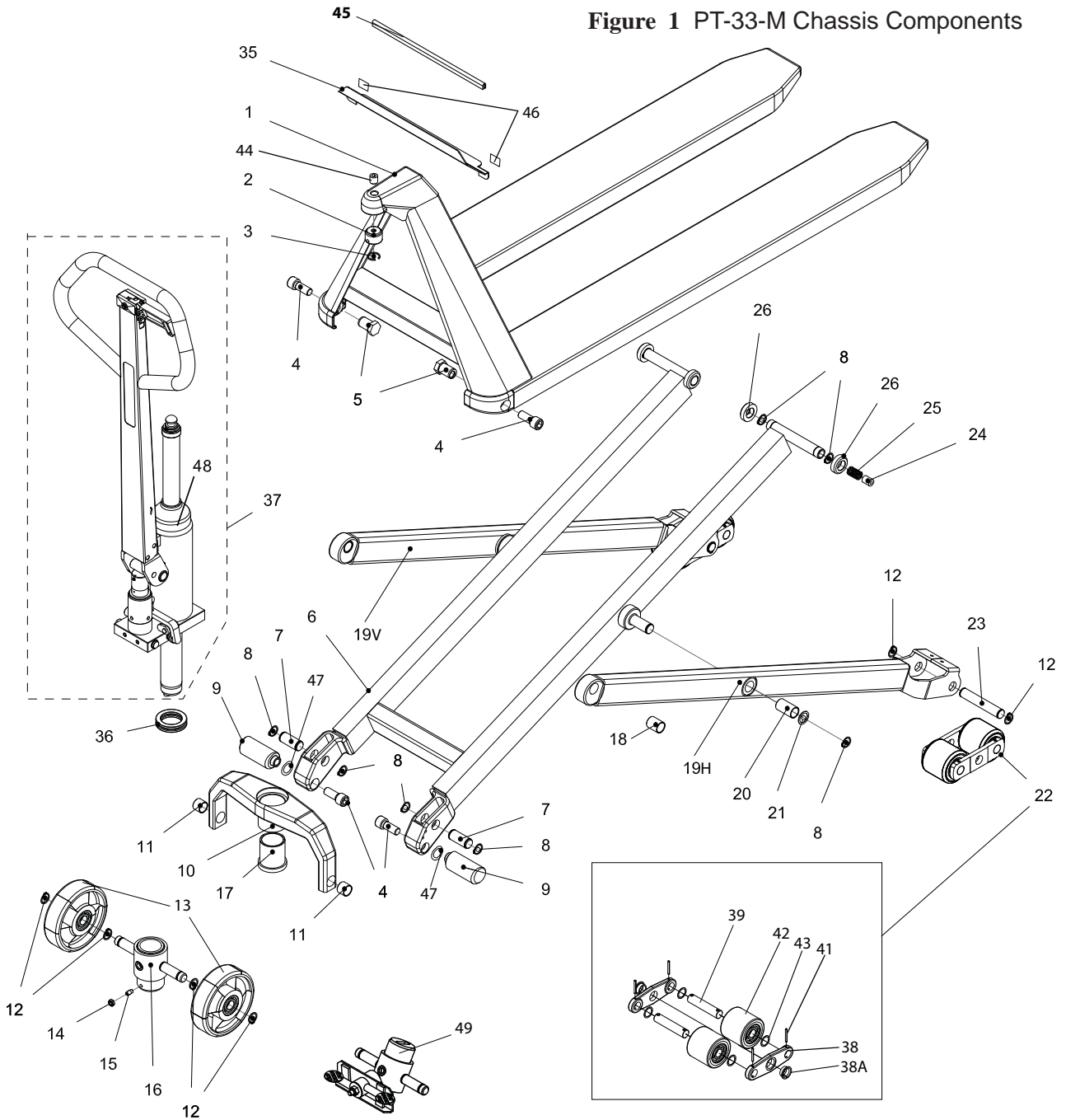

Pos.	Description
1	Chassis 480x700
	Chassis 480x900
	Chassis 480x1200
	Chassis 480x1520
	Chassis 540x700
	Chassis 540x900
	Chassis 540x1200
	Chassis 540x1520
	Chassis 540x2000
	Chassis 680x700
	Chassis 680x900
	Chassis 680x1200
	Chassis 680x1520
	Chassis 680x2000

Pos.	Description
2	Ball Socket
3	Spring Ring
4	Screw
5	Eccentric Nut Eccentric Nut "2000/90mm"

PT-33-M Chassis Components Spare Parts List continued on the next page.

PT-33-M Chassis Components Spare Parts List

Pos.	Description	
6	Double Leg 480x700 Double Leg 480x900 Double Leg 480x1200 Double Leg 480x1520	
	Double Leg 540x700 Double Leg 540x900 Double Leg 540x1200 Double Leg 540x1520 Double Leg 540x2000 110mm Double Leg 540x2000 90mm	
	Double Leg 680x700 Double Leg 680x900 Double Leg 680x1200 Double Leg 680x1520 Double Leg 680x2000 110mm Double Leg 680x2000 90mm	
	7	Axle
	8	Locking Ring
	9	Support Leg Support Legs "1520" Support Legs "2000"
	10	Thrust Plate 480 Thrust Plate 540 Thrust Plate 680
	11	Nylon Bushing
	12	Locking Ring
	13	Steering Wheel nylon Ø150 W/B Steering Wheel, steel Ø150 W/B Steering Wheel poly, w/bearing Steering Wheel, vulk. Ø150 m/l Steering Wheel m/L Anti static
		Steering Wheel/480, nyl., Ø150 W/B Steering Wheel/480 vulk. Ø150 Steering Wheel/480 poly w/b Steering Wheel/480 Anti static Steering Wheel/480 steel Ø150 W/B
		14
15		Pointed Screw
16		Wheel Holder cpl.
17	Bushing	
18	Bushing	
19H	Single leg cpl. 700 right Single leg cpl. 900 right Single leg cpl. 1200 right Single leg cpl. 1520 right Single leg cpl. 2000 r. 110mm Single leg cpl. 2000 r. 90mm	

Pos.	Description	
19V	Single leg cpl. 700 left Single leg cpl. 900 left Single leg cpl. 1200 left Single leg cpl. 1520 left Single leg cpl. 2000 l. 110mm Single leg cpl. 2000 l. 90mm	
	20	Bushing
	21	Washer
	22	Tandem cpl. Ø75 nylon Tandem cpl. Ø75, polyurethan Tandem cpl. Ø75, vulkollan Tandem cpl. Ø75, steel
		23
24	Support Stud	
25	Compression Spring	
26	Fork Roller	
35	Tray f/triangle 480 Tray f/triangle 540 Tray f/triangle 680	
	36	Thrust Bearing
	37	Pump cpl. 700 with handle Pump cpl. 900 with handle Pump cpl. 1200, 1520, 2000 w/h Pump cpl. 2000 h13=110mm w/h
Exchange pump with handle Exchange pump without handle		
38	Fittings	
38A	Bushings	
39	Tandem Axle	
41	Tubular Pin	
42	Tandem Wheels Ø75 Nylon b. m/b Tandem Ø75 poly with bearing Tand. wheel Ø75 vulk with bearing Tandem Ø75 steel with bearing	
	43	Washer
	44	Pointed Screw
45	Rubber Profile	
46	Adhesive Pad	
47	Toothed Washer	
48	Pump cpl, 700 Pump cpl. 900 Pump cpl. 1200, 1520, 2000 Pump cpl. 2000 (h3=110mm)	
	49	Parking Brake

Figure 2 PT-33-M Cylinder & Handle Components

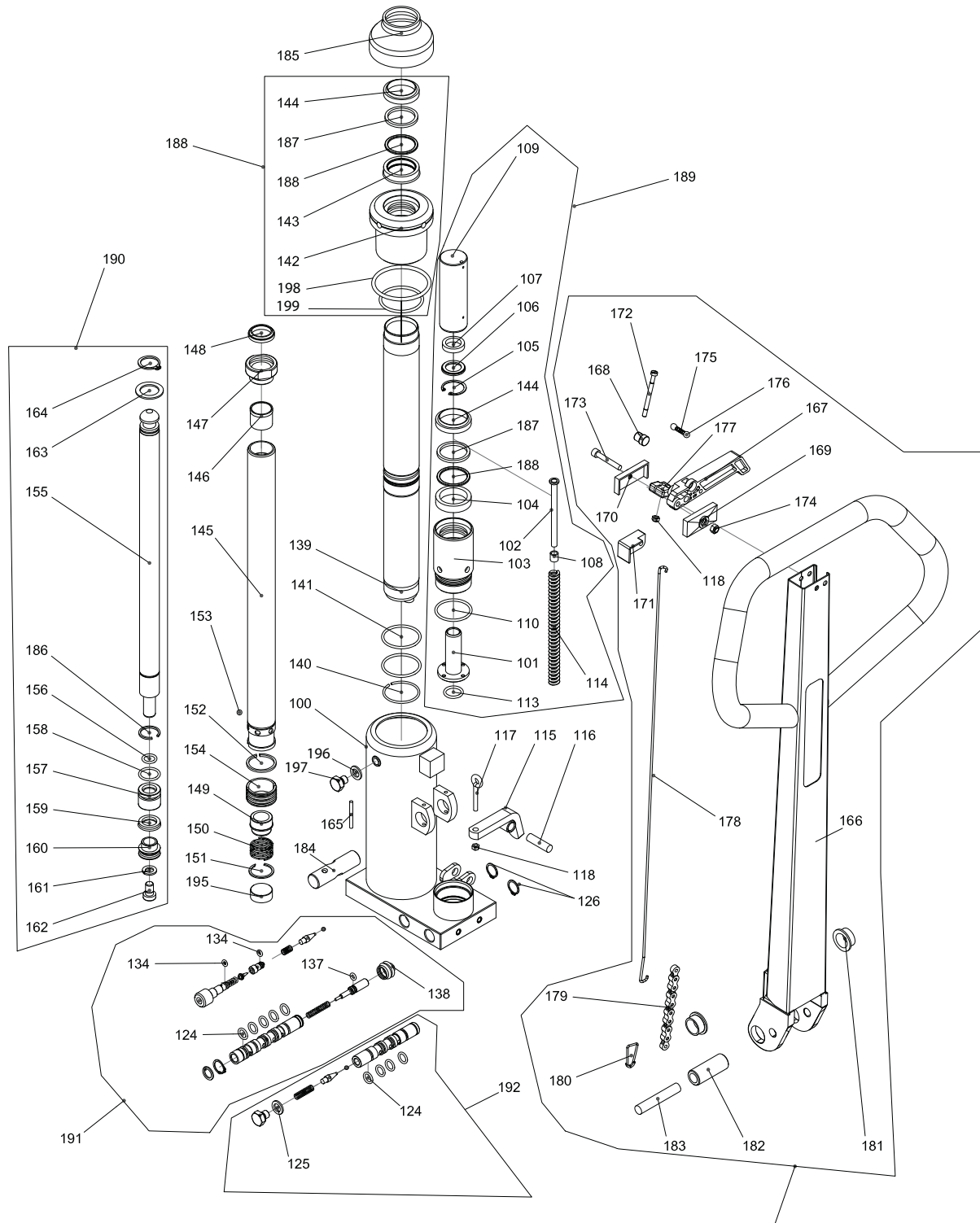

PT-33-M Cylinder & Handle Components Spare Parts List

Pos.	Description
100+	Pump housing cpl.
101+	High pressure piston
102+	Spring guide
103+	Pump cylinder
104	U-Sleeve
105+	Locking ring
106+	Sleeve washer
107	U-Sleeve
108+	Guide ring
109+	Pump piston cpl.
110+	O-ring
113+	O-ring
114+	Spring
115	Release arm cpl.
116+	Tubular pin
117+	Eye bolt
118+	Lock nut
124+	O-ring
125+	Gasket ring
129+	Gasket ring
130+	Valve casing
134+	O-ring
137+	O-ring
138+	Rubber sleeve
139+	Bottom cylinder
140+	Spring ring
141+	O-ring
142+	Top section
143+	U-Sleeve
144+	Wiper seal

Pos.	Description
145+	Lifting cylinder
146+	Bronze bushing
147+	Bronze guide
148+	Sleeve
149+	Ball stop
150+	Spring
151+	Locking ring
152+	Locking ring
153+	Ball
154+	Bronze piston
155+	Piston rod 700 Piston rod 900 Piston rod 1200
156+	O-ring
157+	Piston
158+	O-ring
159+	Sleeve
160+	Piston f/ball
161+	Spring washer
162+	Screw
163	Washer
164+	Locking ring
165	Tubular pin
166	Handle
167	Release lever
168	Plastic pin
169	Top for handle, front
170	Top for handle, rear
171	Top for handle, center
172	Screw

Pos.	Description
173	Screw
174	Lock nut
175	Spring
176	Ball
177	Adjusting piece
178	Release rod
179	Chain
180	Chain eye
181	Bushing
182	Roller
183	Tubular pin
184	Axle for handle
185+	Rubber sleeve
186	Spring ring
187	Quad ring
188	Backup ring
188+	Top section, cpl.
189+	Pump cylinder cpl.
190+	Piston rod 700, cpl. Piston rod 900, cpl. Piston rod 1200, 1520, 2000 cpl.
191+	Valve insert cpl.
192+	Valve insert cpl. high pressure
193	Handle cpl.
194+	O-ring
195+	Stop block for piston rod
196	Plug gasket
197	Valve screw
198	O-ring
199	O-ring

All + marked parts include in pump cpl.

Figure 5 PT-33-E Electric Wiring Diagram: Control Current

5A : Fuse f/ control current
 M.V : Solenoid valve
 K1 : Main relay
 K2 : Pumprelay

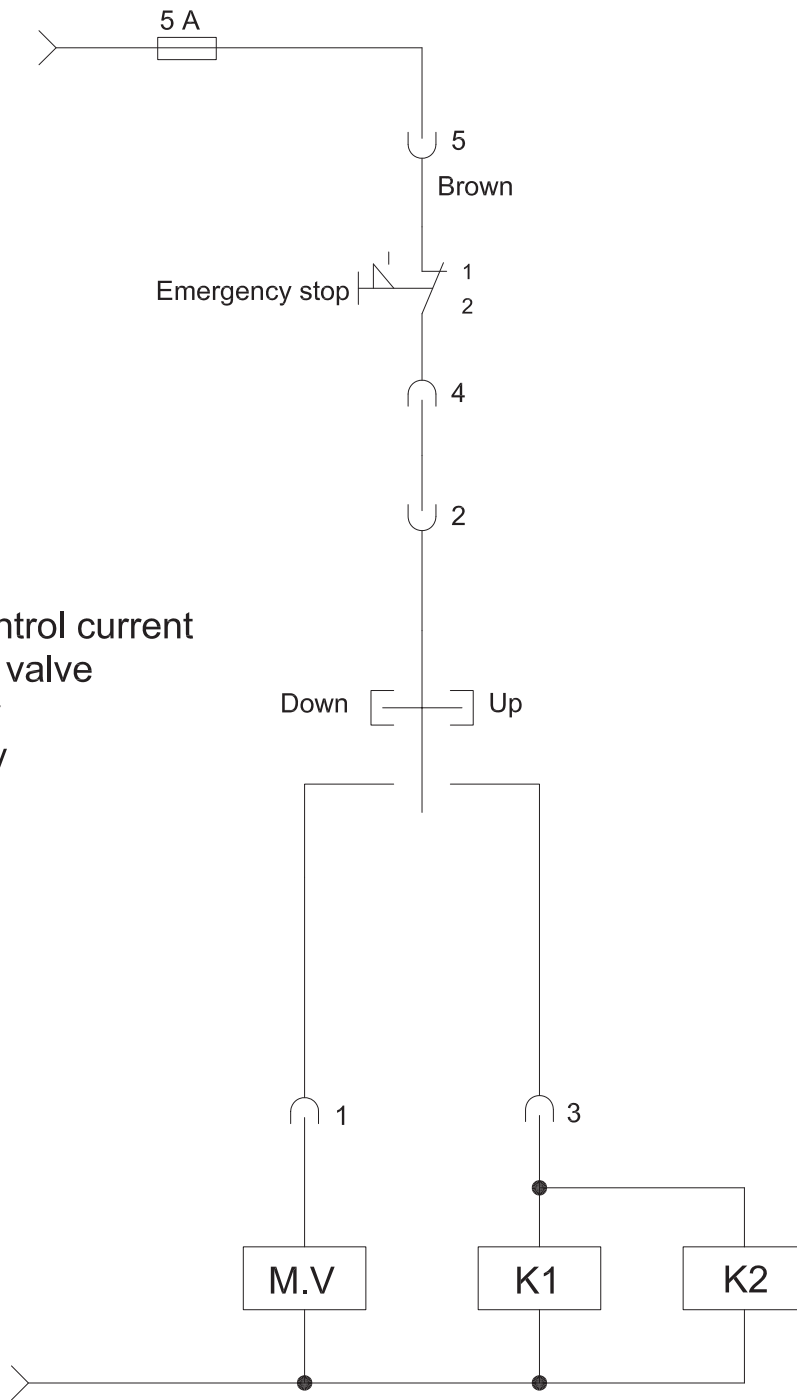
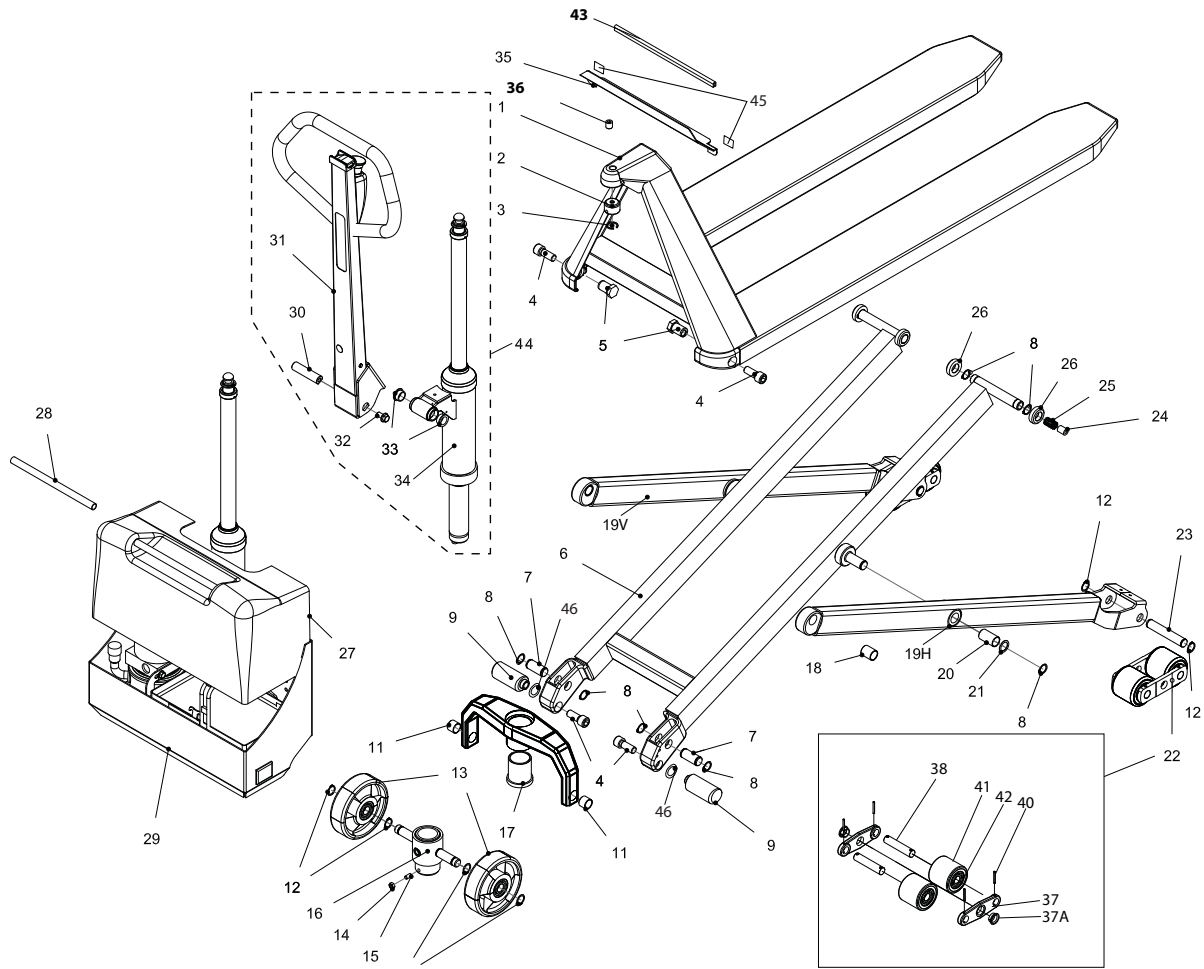

Figure 6 PT-33-E Chassis Components



Pos.	Description
1	Chassis 480x700
	Chassis 480x900
	Chassis 480x1200
	Chassis 480x1520
	Chassis 540x700
	Chassis 540x900
	Chassis 540x1200
	Chassis 540x1520
	Chassis 540x2000
	Chassis 680x700
Chassis 680x900	
Chassis 680x1200	
Chassis 680x1520	
Chassis 680x2000	
2	Ball Socket
3	Spring Ring
4	Screw

Pos.	Description
5	Eccentric Nut Eccentric Nut "2000/90mm"
6	Double Leg 480x700
	Double Leg 480x900
	Double Leg 480x1200
	Double Leg 480x1520
	Double Leg 540x700
	Double Leg 540x900
	Double Leg 540x1200
	Double Leg 540x1520
	Double Leg 540x2000 110mm
	Double Leg 540x2000 90mm
Double Leg 680x700	
Double Leg 680x900	
Double Leg 680x1200	
Double Leg 680x1520	
Double Leg 680x2000 110mm	
Double Leg 680x2000 90mm	

Pos.	Description
7	Axle
8	Locking Ring
9	Support Leg Support Legs "1520" Support Legs "2000"
11	Nylon Bushing
12	Locking Ring
13	Steering Wheel nylon Ø150 W/B Steering Wheel, steel Ø150 W/B Steering Wheel poly, w/bearing Steering Wheel, vulk. Ø150 m/l Steering Wheel m/L Anti static
	Steering Wheel/480, nyl., Ø150 W/B Steering Wheel/480 vulk. Ø150 Steering Wheel/480 poly w/b Steering Wheel/480 w/m Anti static Steering Wheel/480 steel Ø150 W/B
14	Nut
15	Pointed Screw
16	Wheel Holder cpl.
17	Bushing
18	Bushing
19H	Single leg cpl. 700 right Single leg cpl. 900 right Single leg cpl. 1200 right Single leg cpl. 1520 right Single leg cpl. 2000 r. 110mm Single leg cpl. 2000 r. 90mm
	Single leg cpl. 700 left Single leg cpl. 900 left Single leg cpl. 1200 left Single leg cpl. 1520 left Single leg cpl. 2000 l. 110mm Single leg cpl. 2000 l. 90mm
	Bushing
	Washer
	Tandem cpl. Ø75 nylon Tandem cpl. Ø75, polyurethan Tandem cpl. Ø75, vulkollan Tandem cpl. Ø75, steel
23	Wheel Axle
24	Support Stud

Pos.	Description
25	Spring
26	Fork Roller
27	Battery cover cpl.
28	Plastic Tube
29	Pump chassis 480x700 Pump chassis cpl. 480x900 Pump chassis cpl. 480x1200
	Pump chassis cpl. 540x700 Pump chassis cpl. 540x900 Pump chassis cpl. 540x1200
	Pump chassis cpl. 680x700 Pump chassis cpl. 680x900 Pump chassis cpl. 680x1200
30	Handle Axle
31	Handle cpl.
32	Screw
33	Bushing
34	Cylinder cpl. 700 Cylinder cpl. 900 Cylinder cpl. 1200, 1520, 2000 Cylinder cpl. 2000 110 mm
	Tray f/triangle 480 Tray f/triangle 540 Tray f/triangle 680
	Pointed Scre
	Fittings
37A	Bushing
38	Tandem Axle
40	Tubular Pin
41	Tandem Wheels Ø75 Nylon b. m/b Tandem Ø75 poly with bearing Tandem Ø75 vulk with bearing Tandem Ø75 steel with bearing
	Ball bearing
	Rubber Profile
44	Cylinder cpl. 700 with handle Cylinder cpl. 900 with handle Cylinder cpl. 1200 with handle
	Adhesive Pad
	Toothed Washer

Figure 7 PT-33-E Cylinder

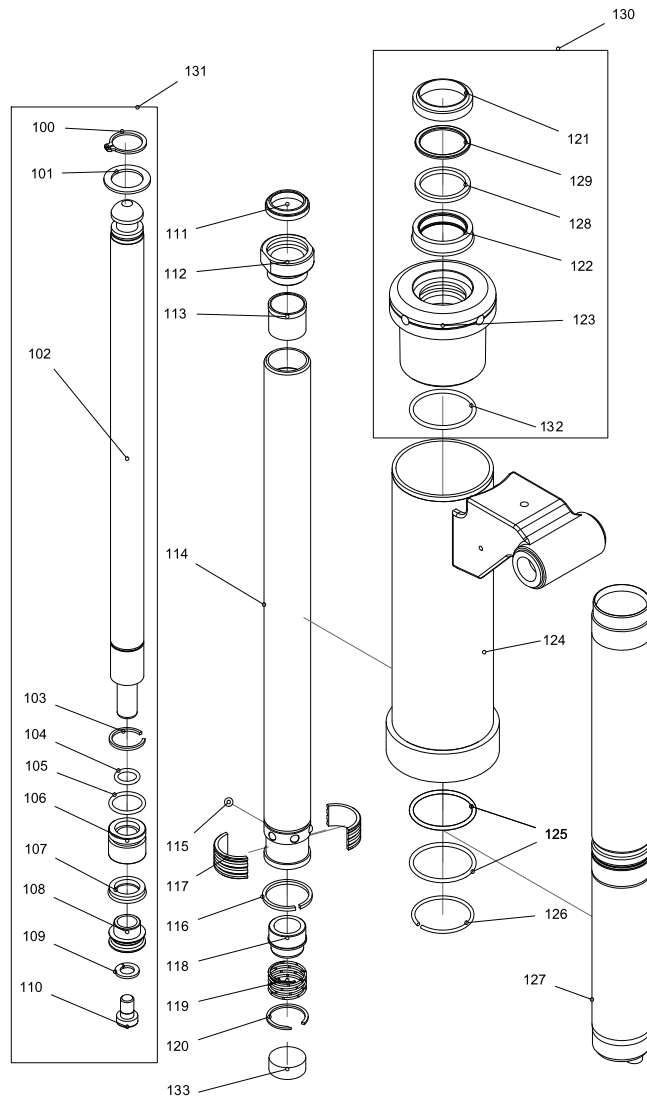

Pos.	Description
100	Locking Ring
101	Washer
102	Piston rod 700 Piston rod 900 Piston rod 1200
103	Spring Ring
104	O-Ring
105	O-Ring
106	Piston
107	Sleeve
108	Piston f/ball
109	Spring Washer
110	Screw

Pos.	Description
111	Sleeve
112	Bronze Guide
113	Bronze Bushing
114	Lifting Cylinder
115	Ball
116	Locking Ring
117	Bronze Piston
118	Ball Stop
119	Spring
120	Locking Ring
121	Scraper Ring
122	U-Sleeve
123	Top Section

Pos.	Description
124	Cylinder Housing
125	O-Ring
126	Spring Ring
127	Bottom Cylinder
128	Quad Ring
129	Backup Ring
130	Top Section, cpl.
131	Piston rod 700, cpl. Piston rod 900, cpl. Piston rod 1200, cpl.
132	O-Ring
133	Stop block f/piston rod

Figure 8 PT-33-E Pump Chassis

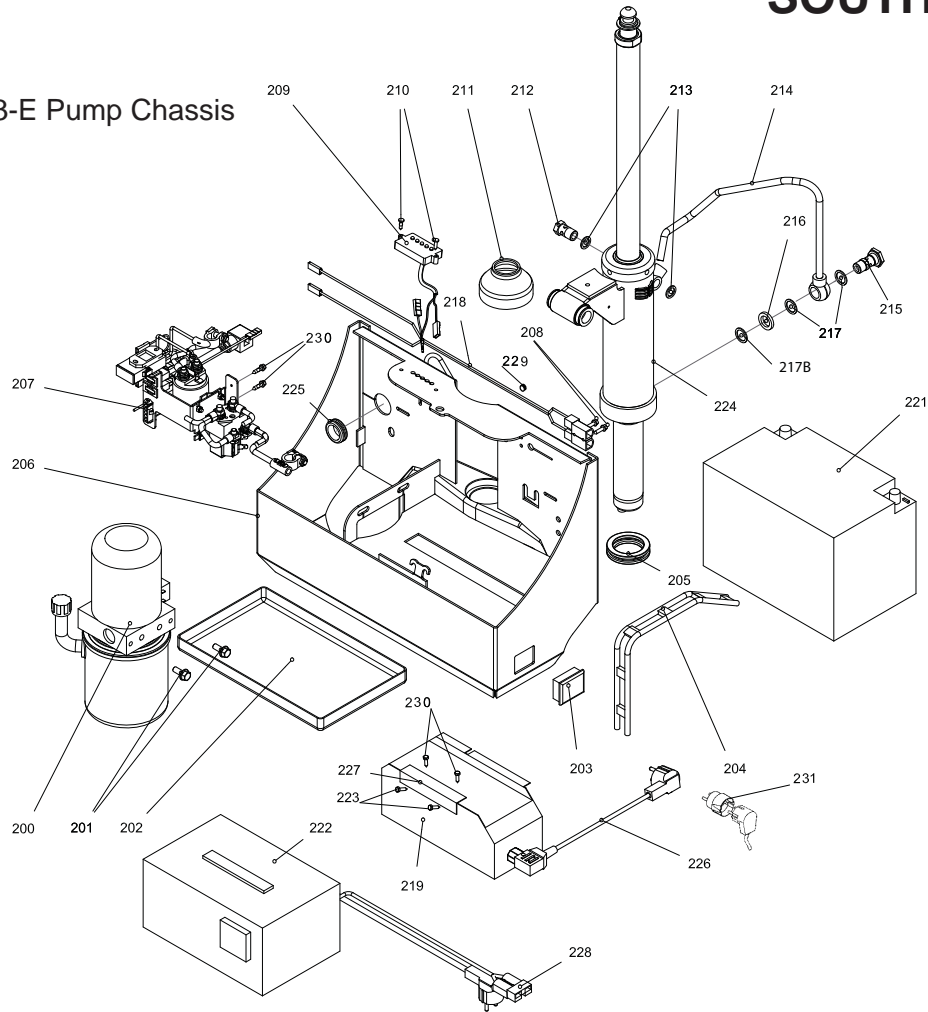

Pos.	Description
200	Hydraulic Pump HPI 0.9 KW
201	Screw
202	Battery Tray
203	Plastic Cover
204	Rubber Strap for Battery
205	Thrust Bearing
206	Pump Chassis 480 Pump Chassis 540 Pump Chassis 680
207	Relays module
208	Pop Rivet
209	Battery Monitor 12V
210	Screw
211	Rubber Sleeve
212	Banjo Bolt
213	Copper Washer
214	Hydraulic hose banjo bolt
215	Flow valve extern \varnothing 1.8 mm
216	Space Washer
217	Sealing Washer
217B	Sealing Washer Usit

Pos.	Description
218	Charger Cable
219	Built-in Charger 12V 11A Incorp. Charger 12V/11A For maintenance free battery
221	Batt. tubular 12V 48Ah/5h acid Semi-trak 12V 60Ah/5h w/acid Batt. maintenance free 12V 51Ah/5h
222	Logitrans charger 12V 11Ah Charger 12V 11A For maintenance free battery
223	Pop Rivet
224	Cylinder cpl. 700 Cylinder cpl. 900 Cylinder cpl. 1200, 1520, 2000 Cylinder cpl. 2000 110 mm
225	Cable lead-in
226	Mains cable
227	Bracket
228	Charger Plug
229	Cable lead-in
230	Pop Rivet
231	Adapter for ground on plug UK Adaptor for ground on plug DK

Figure 9 PT-33-E Relay

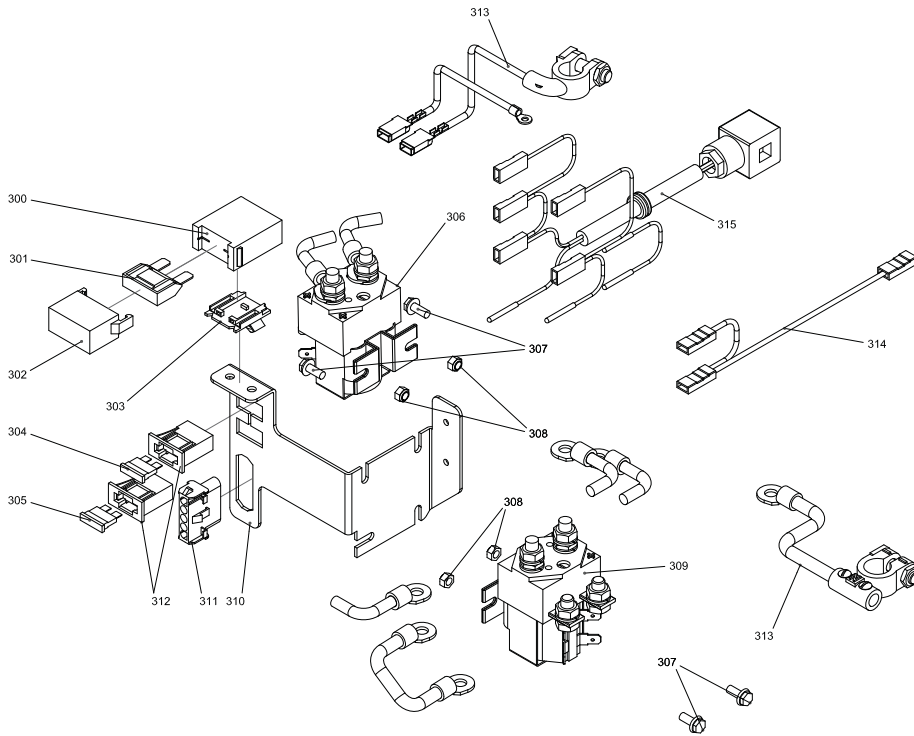

Pos.	Description
300	Fuse Holder
301	Fuse Maxi Fuse 80 Amp.
302	Plastic cap f/fuse holder
303	Fitting Plate
304	Fuse 5 Amp.
305	Fuse 30 Amp.
306	Relay, 12V
307	Screw
308	Lock Nut
309	Pump Relay 12V
310	Replays Plate
311	Female multiple plug
312	Fuse Holder
313	Set of cables
314	Set of cables
315	Set of cables for pump

Figure 10 PT-33-E Pump

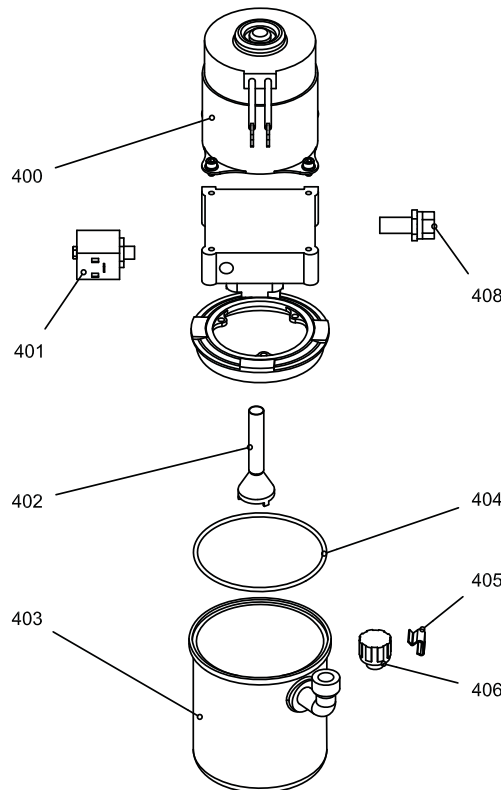

Pos.	Description
400	Motor 12V
401	Magnetic valve cpl.
402	Suction strainer
403	Oil tank HPI 1.5 L.
404	O-Ring for flange/tank
405	Clips for oil tank
406	Filler cab
408	Overpressure valve

Figure 11 PT-33-E Handle

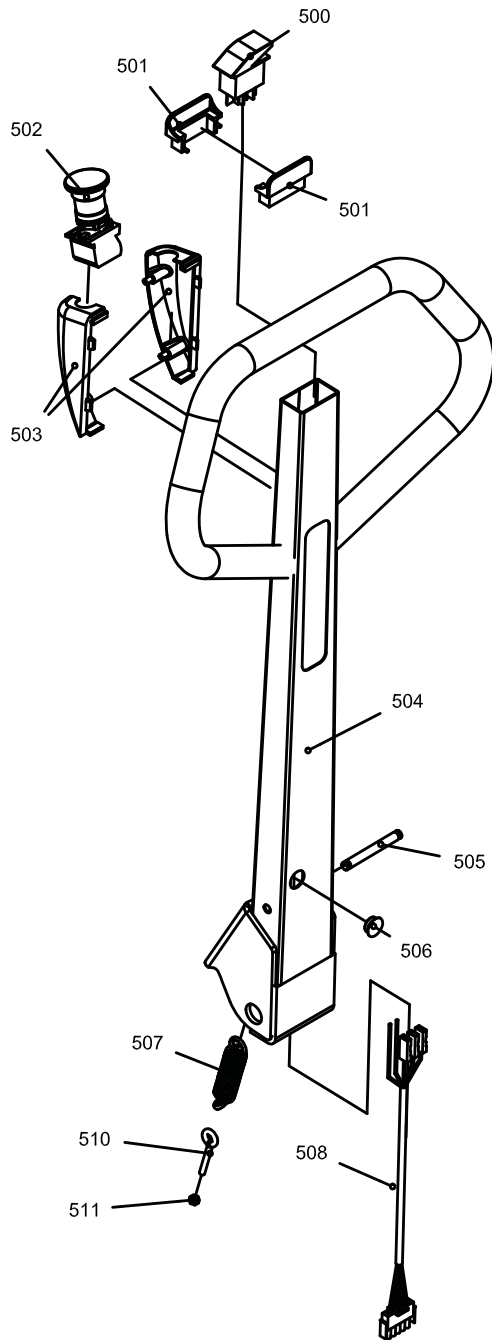

Pos.	Description
500	Tilting switch
501	Contact carrier
502	Emergency stop switch
503	Holder emergency stop
504	Handle
505	Transverse pin for spring
506	Rubber plug
507	Spring
508	Handle cable
510	Eye bolt
511	Lock nut

Figure 12 PT-33-E Parking Brake

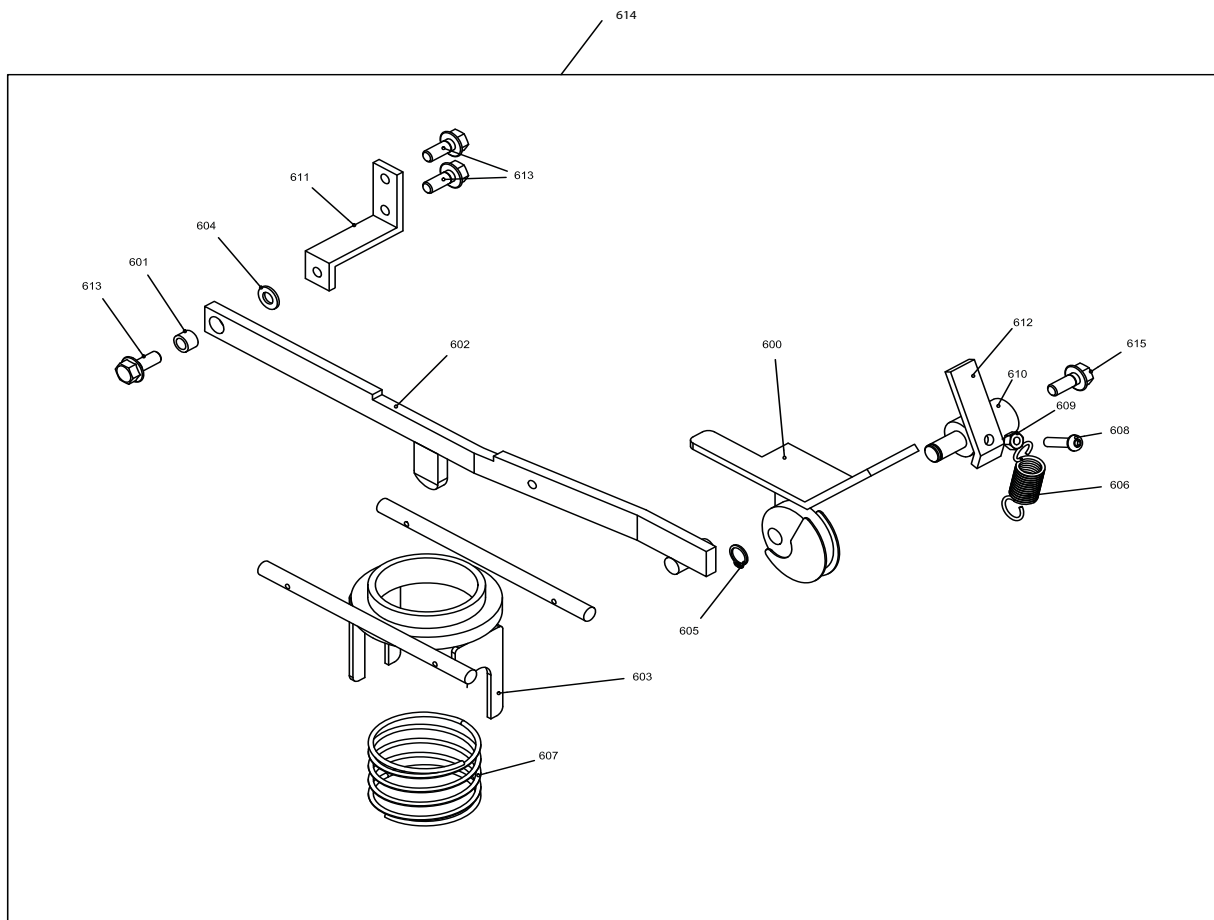

Pos.	Description
600	Brake pedal cpl.
601	Bushing f/brake
602	Thrust support f/brake
603	Brake component
604	Washer
605	Circlip
606	Spring
607	Spring

Pos.	Description
608	Screw
609	Lock nut
610	Adjusting pin f/brake
611	Angle plate for fittings
612	Stop arm f/brake
613	Screw
614	Parking brake
615	Screw

Figure 13 PT-33-E Topstop

480

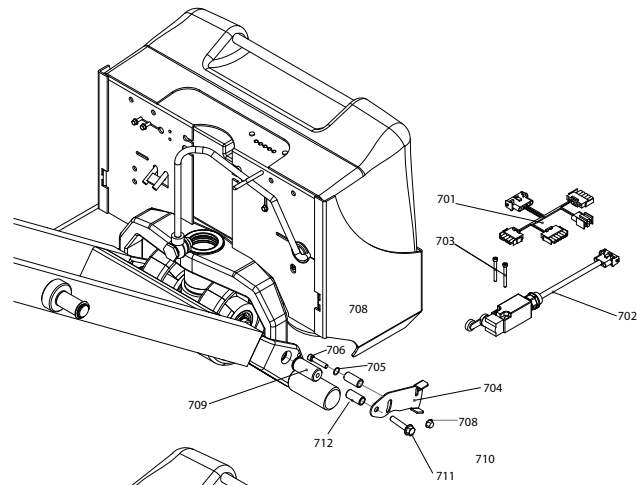

520, 680

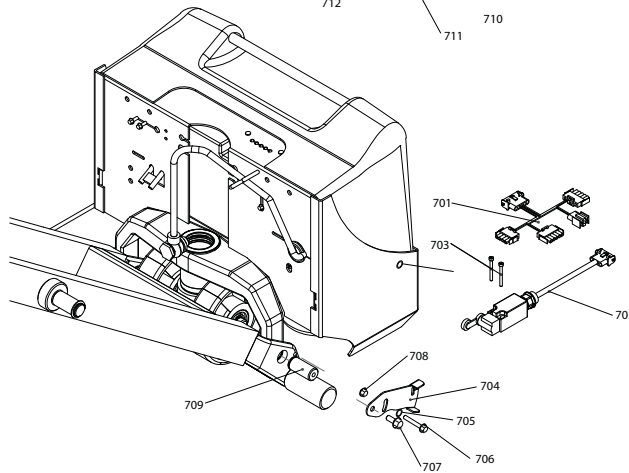

Pos.	Description
701	Adaptor
702	Stop switch w/cable+plug
703	Screw
704	Switch plate "680" Switch/top stop 540x1520+2000 Switch/bottom stop 540x1520+2000 Switch/top stop 680x1520+2000 Switch/bottom stop 680x1520+2000
705	Washer

Pos.	Description
706	Screw
707	Screw
708	Lock nut
709	Axle
710	Screw
711	Screw
712	Space pipe remote control

2 YEAR WARRANTY

Southworth Products Corp warrants this product to be free from defects in material or workmanship for a period of **2 years** of single shift usage from date of shipment, providing claim is made in writing within that time period. This warranty shall not cover modified designs for special applications, failure or defective operation caused by misuse, misapplication, negligence or accident, exceeding recommended capacities, failure to perform required maintenance or altering or repairing, unless alteration is authorized by Southworth Products Corp. Except as set forth herein, there are no other warranties, express or implied, including the warranties of merchantability and fitness for a particular purpose, all of which are hereby excluded.

All **batteries have a 90 day parts and labor** warranty, this warranty covers any defects in material and workmanship from the date of shipment.

Southworth Products Corp makes no warranty or representation with respect to the compliance of any product with state or local safety or product standard codes, and any failure to comply with such codes shall not be considered a defect of material or workmanship under this warranty. Southworth Products Corp shall not be liable for any direct or consequential damages arising out of such noncompliance.

Southworth Products Corp's obligation under this warranty is limited to the replacement or repair of defective components at its factory or another location at Southworth Products Corp's discretion. This is buyer's sole remedy. Except as stated herein, Southworth Products Corp will not be liable for any loss, injury or damage to persons or property, nor for direct, indirect, or consequential damage of any kind, resulting from failure or defective operation of said product.

This warranty may be altered only in writing by Southworth Products Corp, Portland, Maine.

SOUTHWORTH
making work faster, safer, and easier

SOUTHWORTH PRODUCTS CORP
P.O. Box 1380, Portland, ME 04104-1380
Telephone: (800) 743-1000 • (207) 878-0700
Fax: (207) 797-4734
www.SouthworthProducts.com

SOUTHWORTH

We'll Show You How

Southworth is the world class supplier of products designed to improve productivity and enhance safety. Our staff has over 400 years of engineering experience. If one of our standard products does not meet your needs, our engineers can custom design equipment specifically suited to your material handling application.



Spring PalletPal Load Leveler



Lift with Flush Mount Turntable



Portable Container Tilters



Dock Lifts



Roll on Level Loaders



Portable Lifts



Stretchwrapping



Positioning

Floor to Mezzanine Lifts



Pallet Rotators



For more information, contact Southworth Products

Telephone (800) 743-1000 Fax (207) 797-4734

Email: salesinfo@SouthworthProducts.com