

SOUTHWORTH

Owner's Manual **PalletPal™ 360°** Level Loader



Model # _____

Serial # _____

Placed in Service _____

Southworth Products Corp

P.O. Box 1380, Portland, Maine 04104-1380

Phone 800/743-1000 or 207/878-0700 Fax 207/797-4734

www.SouthworthProducts.com

Service@SouthworthProducts.com

This manual covers all types of PalletPal 360° models including standard finish steel and special finishes like epoxy or hot dipped galvanized.

The PalletPal 360° was introduced in June 2011, and if your unit looks like this you have the correct PalletPal 360° owner's manual.



If your unit looks like the picture below you should NOT use this manual. Go to www.SouthworthProducts.com and download the owner's manual for the original PalletPal titled 'PalletPal (Spring) Manual'.



Please note: This manual was current at the time of printing. To obtain the latest, most updated version, please contact Southworth's Customer Service Department or go to our website: www.SouthworthProducts.com, under the Parts & Service tab you will find a complete list of current owner's manuals to print.

Contents

INTRODUCTION	Page 4
SAFETY	4
Installation Notes	4
Operation Notes – Manual Use	5
Operation Notes – Use with Fork Lift or Stacker	6
SPECIFICATIONS	6
INSTALLATION INSTRUCTIONS	7
Unpacking the Unit	7
Spring Selection Charts	7
Installing the Optional Adjustable Feet	8
Installing the Springs	8-13
OPERATING INSTRUCTIONS	14
Loading Manually	14
Removing Loads Manually	14
Operating Safety – Manual use	14
Loading with a Fork Lift	14
Unloading with a Fork Lift	15
Moving the PalletPal.....	15
MAINTENANCE	15
Routine Periodic Maintenance.....	15
TROUBLESHOOTING	16
ORDERING REPLACEMENT PARTS	17
WARRANTY	Back of manual

List of Figures

Fig. 1	Safety Labels	5
Fig. 2	Pinch Points	5
Fig. 3	Orange Spring Installed	8
Fig. 4-17	Step by Step Installation	9 - 13
Fig. 18	Spring Mounting Positions	13
Fig. 19	Loading Manually	14
Fig. 20	Unloading Manually	14
Fig. 21	Loading with a Fork Lift	15
Fig. 22	Unloading with a Fork Lift	15
Fig. 23	Moving the PalletPal	15

Introduction

The PalletPal™ Level Loader is a simple device which will automatically maintain a load at the ideal height for manual loading and unloading. If a palletized load is placed on the unit, the unit gradually rises as boxes or parts are removed. This automatically maintains the top of the load at the correct working height.

The unit may also be used in another way. An empty pallet may be placed on the PalletPal. The unit gradually lowers as boxes or parts are added. Again, this keeps the top of the load at the correct height. Complete pallets may be loaded or unloaded using a fork lift.

Each PalletPal unit includes a steel or stainless steel scissor lift mechanism and at least one large compression spring. The springs are chosen to match the weight and height of a fully loaded pallet. Springs are available for a wide range of weight and height combinations. The PalletPal also includes a shock absorber (optional on the stainless steel model). This eliminates any tendency for the load to bounce on the springs.

This manual contains information to help you to learn about the safe and proper installation, use, and upkeep of your PalletPal unit. Please be sure that this manual is available to anyone who uses or services the PalletPal unit.

PalletPal units may be used in a wide variety of industrial settings. The instructions in this manual are not necessarily all-inclusive, as Southworth cannot anticipate all conceivable or unique situations. **In the interest of safety, please read this whole manual carefully. Be familiar with the contents of this manual before you install or use the PalletPal unit. If you are not sure of the proper procedure to be followed, please call Southworth Products Corporation for more information.**

Southworth's product warranty is shown on the rear cover of this manual. **This instruction manual is not intended to be or to create any other warranty, express or implied, including any implied warranty of merchantability or fitness for a particular purpose, all of which are hereby expressly excluded.** As set forth more specifically in the product warranty, Southworth's obligation under that warranty is limited to the repair or replacement of defective components, which shall be the buyer's **sole remedy**, and Southworth shall not be liable for any loss, injury, or damage to persons or property, nor for any direct, indirect, or consequential damage of any kind resulting from the PalletPal unit.

Safety

The PalletPal unit has been carefully designed to be as safe as possible for operators and service workers. If you take a few common-sense precautions, you will be able to use the unit safely. However, the PalletPal is a powerful unit with moving parts, and is capable of causing personal injury if proper precautions are not taken.

Therefore, throughout this manual, Southworth has identified certain hazards which may occur in the use and servicing of the PalletPal unit, and provided appropriate instructions or precautions which should be taken to avoid these hazards. In some cases, Southworth has also pointed out the consequences which may occur if Southworth's instructions or precautions are not followed. Southworth uses the following system of identifying the severity of the hazards associated with its products:

DANGER! Immediate hazard which will result in severe personal injury or death.

WARNING! Hazard or unsafe practice which could result in severe personal injury or death.

CAUTION! Hazard or unsafe practice which could result in minor personal injury or property damage.

Please read and follow this instruction manual, including all safety instructions and precautions, carefully and completely.

Figure 1 shows the safety labels on this unit. Please be sure that all of the labels are in place, and are visible to the machine operators. Never paint over the labels. If any of the labels are missing, please contact Southworth for replacements. **The safety labels help to protect your workers.**

Installation Notes

WARNING!

The unit must be installed on a firm, nearly-level surface. The frame of the unit must sit firmly on the floor, and the floor must be level. If the frame is not supported correctly, stresses may develop in the frame. The unit may bind or not work easily. The rotating ring may not rotate correctly.

PalletPal 360°

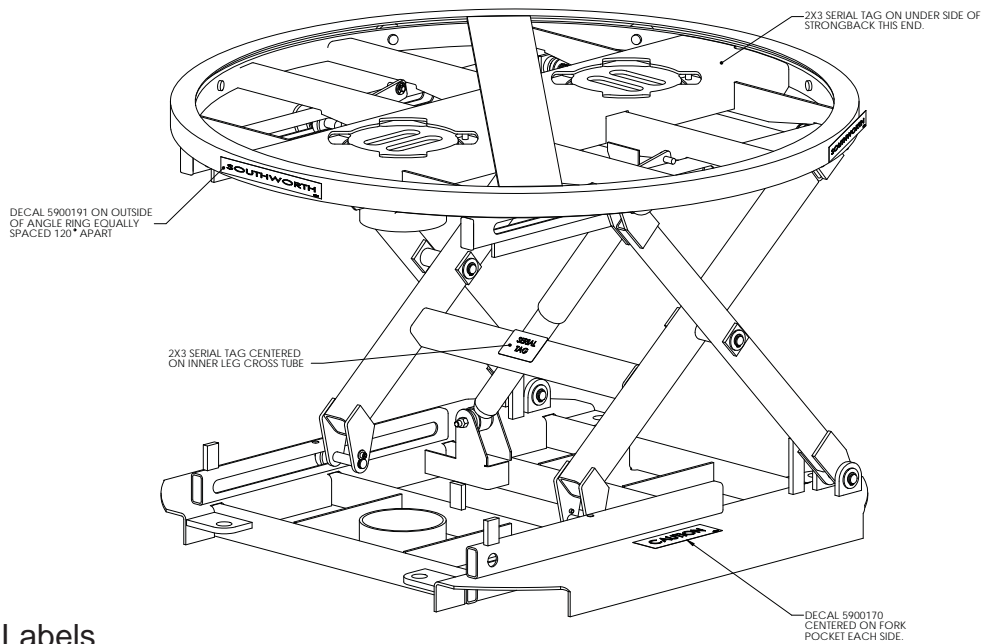

Fig. 1.
Safety Labels

WARNING!

After the springs are installed, if the springs are not seated correctly, or the twist-lock caps are not tightened, the parts may pop loose when the unit is used. You may be hurt, or the load may be damaged.

Operation Notes – Manual Use

WARNING!

Never operate the unit if anyone is sitting or riding on the rotating ring.

WARNING!

Never operate the unit if the load is off-center. The load may shift, and you may be injured. This can also damage the unit.

WARNING!

As the unit moves, keep away from the “pinch points” where metal parts meet. See Fig. 2.

WARNING!

Keep the area around the unit clean. Do not allow any dirt, debris, spilled oil, or excess grease to collect. These materials may cause you to slip while the unit is operating, and you may be injured.

WARNING!

Stay clear of the rotating ring when it is moving. As the pallet turns, a part of the load may rotate around and hit you. Never turn the load when anyone is standing beside the unit.

PalletPal 360°

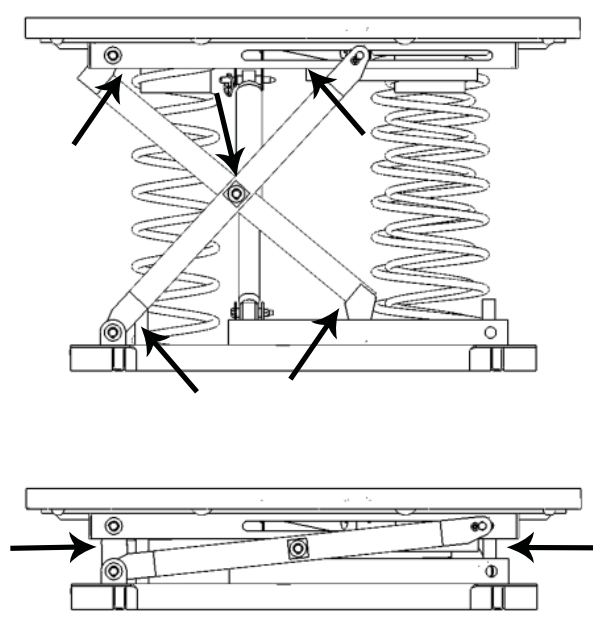

Fig. 2.
Pinch Points

WARNING!

Do not try to use this unit with damaged or broken pallets. Broken pallets may have boards or nails which hang down below the main part of the pallet. As the pallet is turned, these boards or nails may catch on the frame of the unit. This can cause the pallet to stop turning suddenly, causing the load to shift.

You may be injured, and the unit may be damaged. The boards or nails on the bottom of the pallet should not extend down more than 1/8 inch.

load may be damaged, or you may be hurt. Figure 7 shows the correct way to load using a fork lift.

When unloading using a fork lift or stacker –

WARNING!

When removing a load from the unit, lift the load clear of the PalletPal before backing out the fork lift. If you do not do this, the top of the unit may jump up when you remove the fork lift. The unit or the load may be damaged, or you may be hurt. Figure 8 shows the correct way to unload using a fork lift.

Operation Notes – Use with Fork Lift or Stacker

You must take some special precautions when using a fork lift or stacker with the unit:

When loading using a fork lift or stacker –

WARNING!

When adding a load to the unit, lower the forks completely before removing the fork lift. The pallet must be completely supported by the PalletPal. If you do not do this, the load may be dropped when you remove the fork lift. The unit or the

When moving the PalletPal -

Do not move the PalletPal while it is loaded. This will damage the base frame of the unit. The pockets on the base frame are designed to support an unloaded PalletPal, they cannot support any extra weight.

Specifications

Load capacity	400 to 4500 lbs., depending on springs
Load size	50" wide x 50" long x 72" high (max.)
Length	45 1/4 inches
Width (base frame)	36 3/4 inches
Compressed height	9 1/2 inches
Extended height	27 3/4 inches
Rotating ring, outside diameter ..	43 5/8 inches
Rotating ring, inside diameter	40 5/8 inches
Adjustment for sloping floors	Can adjust for floor slope up to 1:25 using optional adjustable feet
Net weight	380 lbs., with (3) springs installed

Installation Instructions

Unpacking the PalletPal 360°

1. Before you start to install the unit, check for local codes and ordinances which may apply. It is your responsibility to obtain any necessary permits.
2. Please read all of these instructions carefully. Be sure to read and understand all of the warnings.
3. Inspect the shipping pallet carefully for any damage which may have affected the unit. If you see signs of damage, tell the trucker. Also make a note of this on the shipping papers which you are asked to sign.
4. Choose the place where you want to use the unit. It is very important that the PalletPal be set up on a smooth

and flat surface. Check the floor surface carefully and make sure that it is free of all loose debris and dirt.

Using optional adjustable feet, the unit can compensate for a slightly sloping floor (1:25), but the surface must be smooth and solid.

CAUTION!

The unit must be installed on a smooth flat surface. If the floor is not flat, this can create stresses in the frame of the unit. The unit may not work properly, or parts of the unit may wear more quickly than they should. You may be hurt or the load may be damaged.

1. **Fill in the weight of a fully loaded pallet here:** _____
(Do not guess. Get actual weight or have a pallet weighed)¹
2. **Fill in the height of a fully loaded pallet here:** _____
(Do not guess. Measure a loaded pallet, including the height of the pallet)¹
3. **Using the chart below, select the correct PalletPal range:** _____

Weight of a Loaded Pallet (load & pallet) lbs.

	0-400#	400-800#	800-1200#	1200-1600#	1600-2000#	2000-2400#	2400-2800#	2800-3200#	3200-3600#	3600-4000#	4000-4500#
58 - 60"	0	0	1	1	1	1	2	2	2	3	3
56 - 58"	0	0	1	1	1	2	2	2	2	3	3
54 - 56"	0	0	1	1	1	2	2	2	2	3	3
52 - 54"	0	1	1	1	1	2	2	2	3	3	3
50 - 52"	0	1	1	1	1	2	2	2	3	3	4
48 - 50"	0	1	1	1	1	2	2	2	3	3	4
46 - 48"	0	1	1	1	1	2	2	3	3	3	4
44 - 46"	0	1	1	1	2	2	3	3	3	4	4
42 - 44"	0	1	1	2	2	2	3	3	4	4	4
40 - 42"	0	1	1	2	2	3	3	3	4	4	4
38 - 40"	0	1	1	2	2	3	3	4	4	4	4
36 - 38"	0	1	1	2	2	3	4	4	4	4	4
34 - 36"	1	1	2	2	3	3	4	4	4	4	---
32 - 34"	1	1	2	3	3	4	4	4	4	---	---
30 - 32"	1	1	2	3	3	4	4	4	4	---	---

¹Caution: PalletPal springs are precisely calibrated and will work best within the load weight and height ranges selected. Selection based on higher or lower than actual weight will result in restricted raising or lowering capability. Should pallet weight or height weight requirements dramatically change, PalletPal can be adapted in the field at any time by simply changing the spring combination

- Range 0** – Pallet Pal with white spring (special order)*
- Range 1** – Pallet Pal with orange spring
- Range 2** – Pallet Pal with orange & gray spring
- Range 3** – Pallet Pal with orange & purple spring
- Range 4** – Pallet Pal with orange, gray & purple spring

*Load range is available, consult Sales for details

Table 1 - Spring selection chart

5. Position the PalletPal beside the point where the unit will be set up.
6. Remove the banding which secures the unit to the pallet. Remove all packing material. Shift the unit to the floor. Support the base as you do this.
7. Check to see that the frame of the unit is sitting firmly on the floor. Try to move or rock the frame of the unit. The base frame should be stable, and should not move. Check to see that the base frame is level. (If any part of the frame is more than $\frac{1}{2}$ " out of level in relation to any other part, you must install the optional adjustable feet to level the unit. See the instructions below.)
8. Remove the springs and lay them out on the floor.
9. If you have any questions about the steps in the installation process, please call Southworth Customer Service at 1-800-743-1000.

Setting up and Installing the Springs

1. The PalletPal will always have at least one spring. This spring has an orange mark, and is larger in diameter than the others. This large orange spring is always placed in the front of the unit. Figure 3 shows the position of the first spring.

The frame of the unit can handle loads of up to 4500 lbs. In order to adapt the unit for different pallet loads, the springs are changed. The springs are chosen to match the weight and height of a fully loaded pallet. A unit may have one to three springs.

Each time the pallet weight or pallet height is changed, the springs may also need to be changed. Table 1 on page 7 show how the springs are selected.



Fig. 3 Orange Spring Installed

Installing the Optional Adjustable Feet

You will need two adjustable wrenches to install the feet. Each foot has a large threaded shaft which fits through one of the large holes in the base frame of the unit.

There are two nuts for each shaft. When each foot is installed, the threaded shaft should include one nut below the base frame and one nut above it. The two nuts are used to clamp against the base frame. The third nut is used to lock the adjustment.

Adjust each of the feet until the frame of the unit is level. All four of the feet must touch the floor. Once the settings are correct, tighten two of the nuts against the base frame. The third nut (above the base frame) is used to lock the setting. Tighten this nut down against the nut below it.

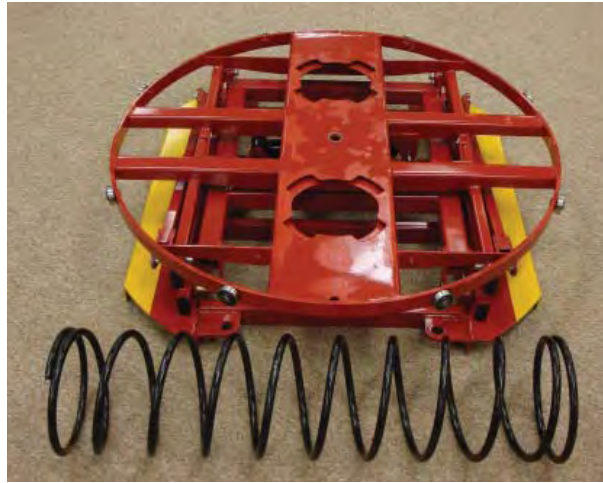

Fig. 4

2. The unit is shipped without springs installed. The installation of the first spring (orange) requires two people. Lift off rotating ring and both yellow bayonets. Set them aside, they will be installed later.



Fig. 5

3. The shock absorber is attached to the top frame of the unit with a pivot pin, and this is held in place by a linch pin. The pivot pint is used to hold the table frame in the raised position. Take a look at the mechanism and note the positions of the parts. Remove the linch pin and remove the pivot pin. Lay the free end of the shock absorber down.



Fig. 6

4. With the help of an assistant, lift the top frame until it hits the upper latch stops.



Fig. 7

5. While holding both latches up and lift the top frame pass the latches until it is at its full, upper most position. Have the assistant hold the weight and insert the pivot pin in the hole in the base frame. See Fig. 8. With the PalletPal in this full upper most position the orange spring can be installed.



Fig. 8

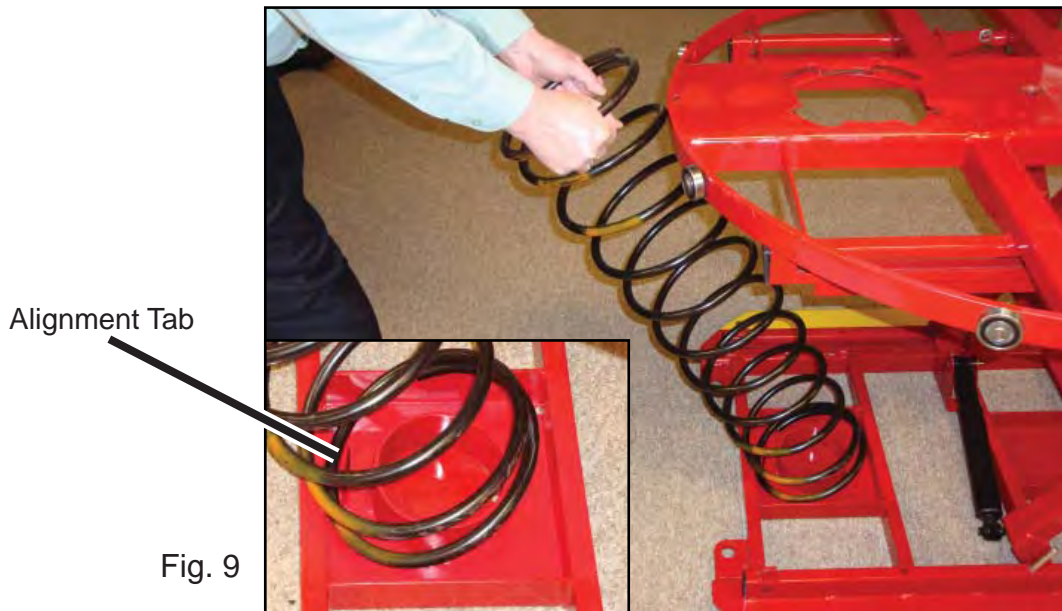

Fig. 9

6. Insert either end of the large orange spring into the lower pocket. Be sure the bottom spring coil is positioned outside the alignment tab as shown.



Fig. 10

7. Grasp the spring by the second or third coil down from the top (do NOT grasp the top coil or rung) and push the spring down and under the edge of the top frame.



Fig. 11

8. While pushing down to compress spring push it forward into the pocket up under the top frame. It will "snap" into position when completely in the pocket.



Fig. 12

CORRECT

Fully inserted into pocket



Fig. 13

INCORRECT

Spring NOT fully inserted into pocket



Fig. 14

9. Remove the shock absorber pivot pin. Push down on top frame until latches engage. (Both latches will drop into place).



Fig. 15

10. Reinstall the shock absorber pivot pin and linch pin.



Fig. 16

11. Install additional springs as needed through the bayonet openings. Reinsert the yellow bayonets and twist to lock them in place.



Fig. 17

12. Reinstall the rotator ring.

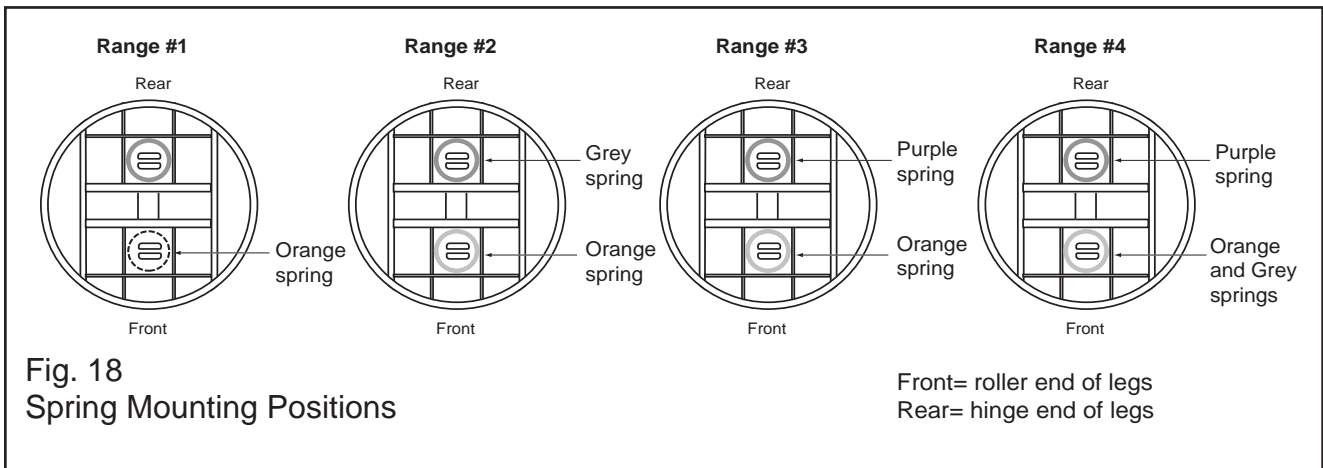

Fig. 18
Spring Mounting Positions

13. Figure 4 shows the position of additional springs if needed. Double-check to be sure you have the correct springs. Refer to Table 1 on page 7 and see that you have the correct springs for your application.

Before using the unit, do a safety check. Be sure that each of the spring bayonet caps is in place and rotated to their locked position. Check the top and bottom of each spring to be sure it is seated correctly. Check the linch pin at the top of the shock absorber. These checks are very important.

The PalletPal 360° is now ready for use!

Operating Instructions

Loading Manually

Add boxes or parts until the pallet is full. Load the pallet in layers. Use the rotating ring to position the pallet to eliminate walking around. The unit will gradually lower the pallet until it reaches the bottom. See Fig. 19.

CAUTION!

Rotate the pallet load. Never place your hands on the rotator ring. You may be hurt.

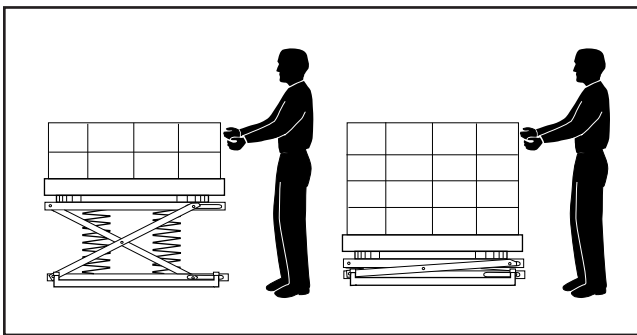

Fig. 19

Loading Manually

Removing Loads Manually

Remove boxes or parts until the pallet is empty. Unload the pallet in layers. Use the rotating ring to position the pallet to eliminate walking around. The unit will gradually raise the pallet. See Fig. 20.

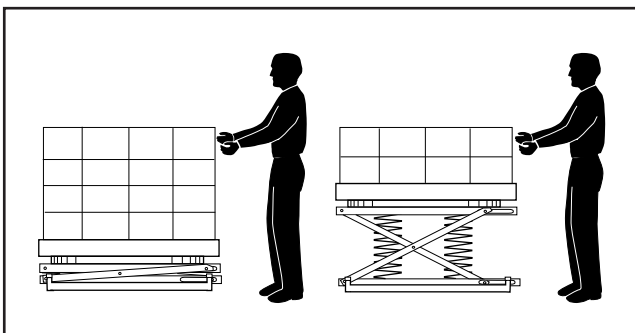

Fig. 20

Unloading Manually

Operating Safety - Manual Use

1. Do not use this unit with a load greater than the rated load. This includes the weight of the payload and the weight of the pallet. Table 1 on page 7 shows how to be sure you have the correct spring combination for your application.
2. Never push the load off of the side of the unit. If you do this, the frame of the unit may jump upward.
3. Never use the unit when anyone is sitting or riding on the rotating ring.
4. Do not try to use this unit with damaged or broken pallets. Broken pallets may have boards or nails which hang down below the main part of the pallet. As the pallet is turned, these boards or nails may catch on the frame. The pallet may stop turning suddenly and this can cause the load to shift. You may be injured and the unit may be damaged. If the boards or nails on the bottom of the pallet extend down more than $\frac{1}{8}$ inch, they will interfere with the turning action.
5. Stay clear of the rotating ring when it is moving. As the pallet turns, a part of the load may rotate around and hit you.
6. Keep the area around the unit clean. Do not allow any dirt, debris, spilled oil, or excess grease to collect. These materials may cause you to slip while the unit is operating and you may be injured.

Loading with a Fork Lift

1. Place the load on the lift, then lower the fork lift. Before removing the load, be sure the unit is carrying the weight, not the fork lift. See Fig. 21.
 - Lower the load until the springs on the PalletPal are fully compressed.
 - Be sure the forks on the lift are clear of the inside of the pallet.

WARNING!

If you skip these steps, the load may drop suddenly when you remove the fork lift. You may be hurt or the unit or load may be damaged.

WARNING!

Never drop the load on the rotating ring. If you do this while the rotating ring is moving, the load may shift. You may be injured or the unit may be damaged. If you drop the load while the rotating ring is stopped, the unit may be damaged.

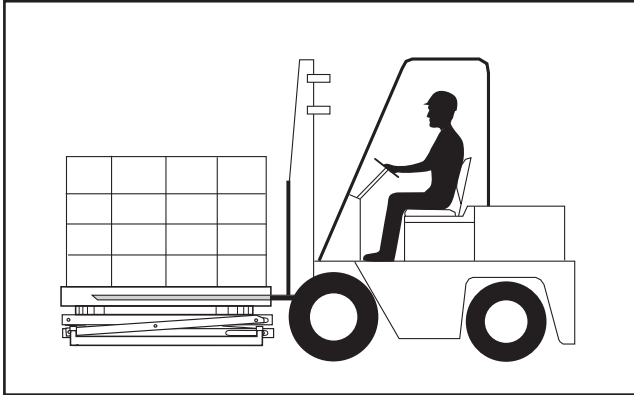

Fig. 21
Loading with a Fork Lift

2. Be sure the load is centered on the unit.

WARNING!

If the load is off-center, it may shift when the rotating ring is turned. You may be hurt or the unit or load may be damaged.

Unloading with a Fork Lift

1. Insert the forks fully into the pallet, and lift the pallet straight up and clear of the top of the unit. See Fig. 22.
- Raise the pallet until the springs on the PalletPal are fully extended.
 - Be sure the pallet clears the top of the rotating ring before you move the fork lift.

WARNING!

If you skip these steps, the unit may jump up suddenly when you remove the pallet. You may be hurt or the unit or load may be damaged.

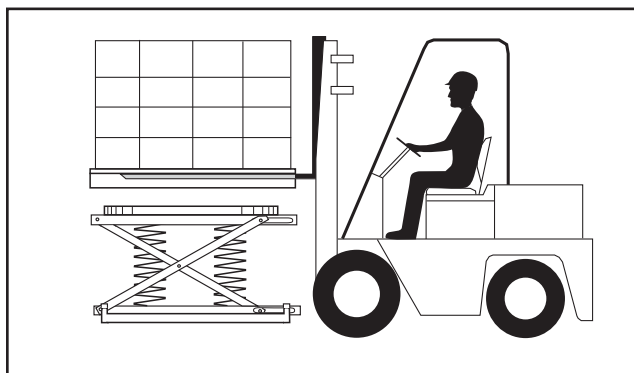

Fig. 22
Unloading with a Fork Lift

Moving the Pallet Pal

CAUTION!

Do not move the Pallet Pal while it is loaded. This will damage the base frame of the unit. The pockets on the base frame are designed to support an unloaded PalletPal, but cannot support any extra weight.

1. Remove any load from the top of the Pallet Pal.
2. Insert the forks into the pockets in the base frame. See Fig. 23.

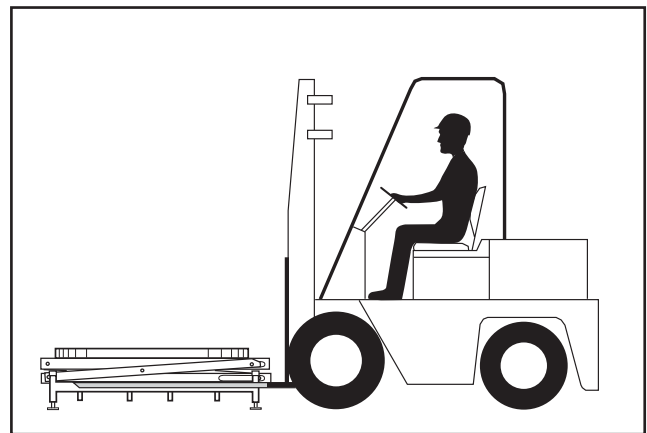

Fig. 23
Moving the Pallet Pal

Maintenance

Routine Periodic Maintenance

Every 90 days -

- Check for loose hardware and signs of excessive wear. On the models where the shock absorber is used, check for signs of leakage.
- Check to be sure that the unit is placed on a firm level surface. If the optional feet are installed, be sure that all four feet are touching the floor and are locked in position.

Troubleshooting

Troubleshooting Check List

Problem	Possible Cause	Check This
The unit lowers too easily (too early).	The spring combination may be too weak for the load.	Check the spring ratings. See Table 1 on page 7.
The unit does not lower enough (too late).	The spring combination may be too strong for the load.	Check the spring ratings. See Table 1 on page 7.
The top of the unit rotates away from you.	The frame of the unit may not be level.	Move the unit to a level surface or install the optional adjusting feet.
The top of the unit bounces.	The shock absorber may be damaged.	Check for leaks or dents. Replace if damaged.
Excessive "rumble" when the ring rotates	Wear or lack of lubrication to bearings under rotating ring.	Remove turntable, lubricate or replace bearings.
Wear or metal flaking from underside of rotating ring.	Normal condition caused by work-hardening of metal.	No repair necessary. This will stop once the rotator ring wears in.

Ordering Replacement Parts

Southworth has carefully chosen the components in your unit to be the best available for the purpose. Replacement parts should be identical to the original equipment. Southworth will not be responsible for equipment failures resulting from the use of incorrect replacement parts or from unauthorized modifications to the unit.

Southworth can supply all replacement parts for your PalletPal. With your order, please include the model number and the serial number of the unit. You can find these numbers on the name plate. This plate is located within the scissors mechanism.

To order replacement parts, please call the Parts Department at (207) 878-0700 or (800) 743-1000. Parts are shipped subject to the following terms:

- FOB factory
- Returns only with the approval of our Parts Department.
- Payment net 30 days (except parts covered by warranty).
- Freight collect (except parts covered by warranty).

Parts replaced under warranty are on a “charge-credit” basis. We will invoice you when we ship the replacement part, then credit you when you return the worn or damaged part.

Parts Department
Southworth Products Corp.
P.O. Box 1380
Portland, Maine, 04104-1380
Telephone: (800)743-1000 or (207)878-0700
FAX: (207)797-4734
Service@SouthworthProducts.com

2 YEAR WARRANTY

Southworth Products Corp warrants this product to be free from defects in material or workmanship for a period of **2 years** of single shift usage from date of shipment, providing claim is made in writing within that time period. This warranty shall not cover modified designs for special applications, failure or defective operation caused by misuse, misapplication, negligence or accident, exceeding recommended capacities, failure to perform required maintenance or altering or repairing, unless alteration is authorized by Southworth Products Corp. Except as set forth herein, there are no other warranties, express or implied, including the warranties of merchantability and fitness for a particular purpose, all of which are hereby excluded.

Southworth Products Corp makes no warranty or representation with respect to the compliance of any product with state or local safety or product standard codes, and any failure to comply with such codes shall not be considered a defect of material or workmanship under this warranty. Southworth Products Corp shall not be liable for any direct or consequential damages arising out of such noncompliance.

Southworth Products Corp's obligation under this warranty is limited to the replacement or repair of defective components at its factory or another location at Southworth Products Corp's discretion. This is buyer's sole remedy. Except as stated herein, Southworth Products Corp will not be liable for any loss, injury or damage to persons or property, nor for direct, indirect, or consequential damage of any kind, resulting from failure or defective operation of said product.

This warranty may be altered only in writing by Southworth Products Corp, Portland, Maine.

SOUTHWORTH

SOUTHWORTH PRODUCTS CORP
P.O. Box 1380, Portland, ME 04104-1380
Telephone: (800) 743-1000 • (207) 878-0700
Fax: (207) 797-4734
www.SouthworthProducts.com

SOUTHWORTH

We'll Show You How

Southworth is the world class supplier of products designed to improve productivity and enhance safety. Our staff has over 400 years of engineering experience. If one of our standard products does not meet your needs, our engineers can custom design equipment specifically suited to your material handling application.



Spring PalletPal Load Leveler



Lift with Flush Mount Turntable



Portable Container Tilters



Dock Lifts



Roll on Level Loaders



Portable Lifts



Stretchwrapping



Positioning

Floor to Mezzanine Lifts



Pallet Rotators



For more information, contact Southworth Products
Telephone (800) 743-1000 Fax (207) 797-4734
Email: salesinfo@SouthworthProducts.com