

SOUTHWORTH

Owner's Manual **PalletPalTM Spring Level Loader**



Model # _____

Serial # _____

Placed in Service _____

Southworth Products Corp

P.O. Box 1380, Portland, Maine 04104-1380

Phone 800/743-1000 or 207/878-0700 Fax 207/797-4734

www.SouthworthProducts.com

Service@SouthworthProducts.com

This manual covers all types of PalletPal Spring models including standard finish steel, stainless steel and special finishes like epoxy or hot dipped galvanized.

Please note: This manual was current at the time of printing. To obtain the latest, most updated version, please contact Southworth's Customer Service Department or go to our website: www.SouthworthProducts.com, under the Parts & Service tab you will find a complete list of current owner's manuals to print.

Contents

INTRODUCTION	Page 4
SAFETY	4
Installation Notes	4
Operation Notes – Manual Use	5
Operation Notes – Use with Fork Lift or Stacker	6
SPECIFICATIONS	6
INSTALLATION INSTRUCTIONS	7
Unpacking the Unit	7
Spring Selection Charts	7
Installing the Optional Adjustable Feet	8
Installing the Springs	8-9
OPERATING INSTRUCTIONS	10
Loading Manually	10
Removing Loads Manually	10
Operating Safety – Manual use	10
Loading with a Fork Lift	10
Unloading with a Fork Lift	11
Moving the PalletPal.....	11
MAINTENANCE	11
Routine Periodic Maintenance.....	11
TROUBLESHOOTING	12
ORDERING REPLACEMENT PARTS	13
WARRANTY	14

List of Figures

Fig. 1	Safety Labels	5
Fig. 2	Pinch Points	5
Fig. 3	Inserting the First Spring	8
Fig. 4	Spring Mounting Positions	9
Fig. 5	Loading Manually	10
Fig. 6	Unloading Manually	10
Fig. 7	Loading with a Fork Lift	11
Fig. 8	Unloading with a Fork Lift	11
Fig. 9	Moving the PalletPal	11

Introduction

The PalletPal™ Level Loader is a simple device which will automatically maintain a load at the ideal height for manual loading and unloading. If a palletized load is placed on the unit, the unit gradually rises as boxes or parts are removed. This automatically maintains the top of the load at the correct working height.

The unit may also be used in another way. An empty pallet may be placed on the PalletPal. The unit gradually lowers as boxes or parts are added. Again, this keeps the top of the load at the correct height. Complete pallets may be loaded or unloaded using a fork lift.

Each PalletPal unit includes a steel or stainless steel scissor lift mechanism and at least one large compression spring. The springs are chosen to match the weight and height of a fully loaded pallet. Springs are available for a wide range of weight and height combinations. The PalletPal also includes a shock absorber (optional on the stainless steel model). This eliminates any tendency for the load to bounce on the springs.

This manual contains information to help you to learn about the safe and proper installation, use, and upkeep of your PalletPal unit. Please be sure that this manual is available to anyone who uses or services the PalletPal unit.

PalletPal units may be used in a wide variety of industrial settings. The instructions in this manual are not necessarily all-inclusive, as Southworth cannot anticipate all conceivable or unique situations. **In the interest of safety, please read this whole manual carefully. Be familiar with the contents of this manual before you install or use the PalletPal unit. If you are not sure of the proper procedure to be followed, please call Southworth Products Corporation for more information.**

Southworth's product warranty is shown on the rear cover of this manual. **This instruction manual is not intended to be or to create any other warranty, express or implied, including any implied warranty of merchantability or fitness for a particular purpose, all of which are hereby expressly excluded.** As set forth more specifically in the product warranty, Southworth's obligation under that warranty is limited to the repair or replacement of defective components, which shall be the buyer's **sole remedy**, and Southworth shall not be liable for any loss, injury, or damage to persons or property, nor for any direct, indirect, or consequential damage of any kind resulting from the PalletPal unit.

Safety

The PalletPal unit has been carefully designed to be as safe as possible for operators and service workers. If you take a few common-sense precautions, you will be able to use the unit safely. However, the PalletPal is a powerful unit with moving parts, and is capable of causing personal injury if proper precautions are not taken.

Therefore, throughout this manual, Southworth has identified certain hazards which may occur in the use and servicing of the PalletPal unit, and provided appropriate instructions or precautions which should be taken to avoid these hazards. In some cases, Southworth has also pointed out the consequences which may occur if Southworth's instructions or precautions are not followed. Southworth uses the following system of identifying the severity of the hazards associated with its products:

DANGER! Immediate hazard which will result in severe personal injury or death.

WARNING! Hazard or unsafe practice which could result in severe personal injury or death.

CAUTION! Hazard or unsafe practice which could result in minor personal injury or property damage.

Please read and follow this instruction manual, including all safety instructions and precautions, carefully and completely.

Figure 1 shows the safety labels on this unit. Please be sure that all of the labels are in place, and are visible to the machine operators. Never paint over the labels. If any of the labels are missing, please contact Southworth for replacements. **The safety labels help to protect your workers.**

Installation Notes

WARNING!

The unit is attached to the skid using metal bands. These bands are under high tension. The edges are sharp. Wear safety glasses and gloves when you handle or cut the banding.

WARNING!

The unit must be installed on a firm, nearly-level surface. The frame of the unit must sit firmly on the floor, and the floor must be level. If the frame is not supported correctly, stresses may develop in the frame. The unit may bind or not work easily. The rotating ring may not rotate correctly.

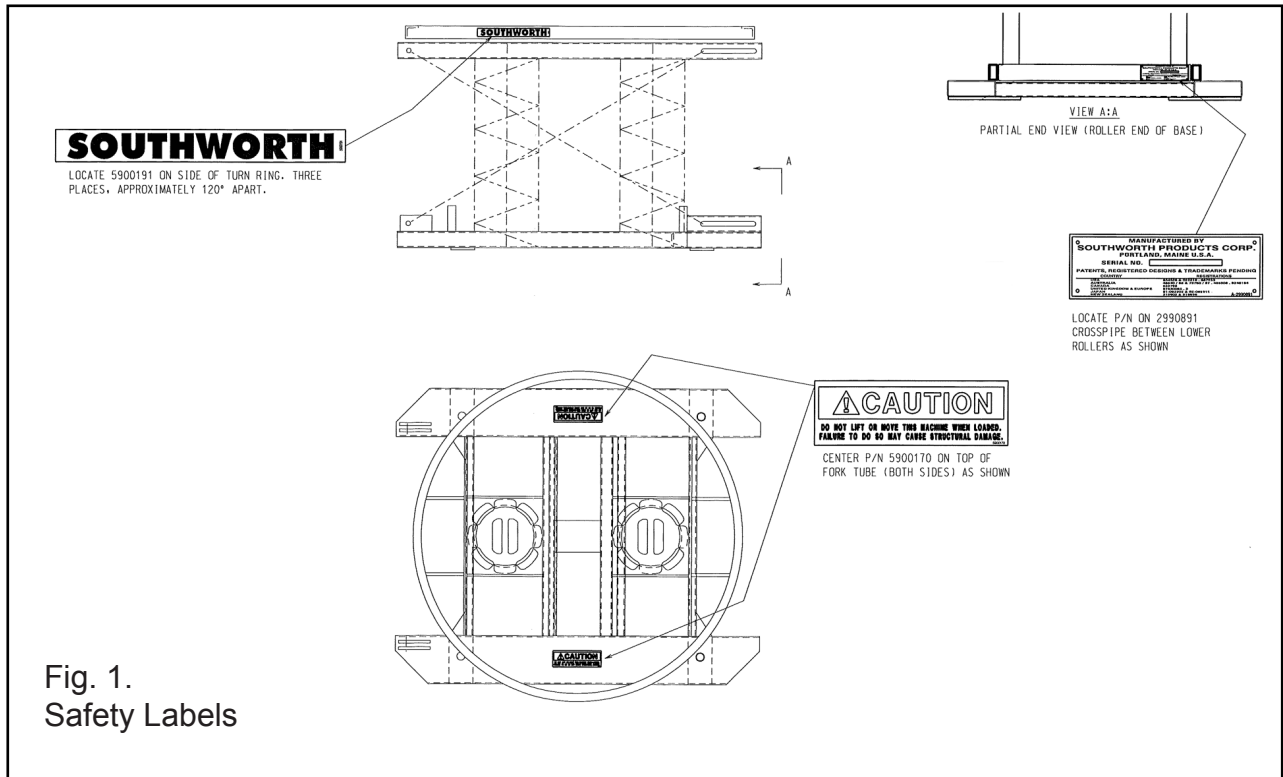

Fig. 1.
Safety Labels

WARNING!

When installing the first (orange) spring, use the maintenance pin to support the frame. See Fig. 3. If you do not do this, the frame of the unit may drop suddenly. You may be hurt, or the unit may be damaged.

WARNING!

Have an assistant help when installing the first (orange) spring. The top of the unit is too heavy to lift safely by yourself.

WARNING!

After the springs are installed, if the springs are not seated correctly, or the twist-lock caps are not tightened, the parts may pop loose when the unit is used. You may be hurt, or the load may be damaged.

Operation Notes – Manual Use

WARNING!

Never operate the unit if anyone is sitting or riding on the rotating ring.

WARNING!

Never operate the unit if the load is off-center. The load may shift, and you may be injured. This can also damage the unit.

WARNING!

As the unit moves, keep away from the “pinch points” where metal parts meet. See Fig. 2.

WARNING!

Keep the area around the unit clean. Do not allow any dirt, debris, spilled oil, or excess grease to collect. These materials may cause you to slip while the unit is operating, and you may be injured.

WARNING!

Stay clear of the rotating ring when it is moving. As the pallet turns, a part of the load may rotate around and hit you. Never turn the load when anyone is standing beside the unit.

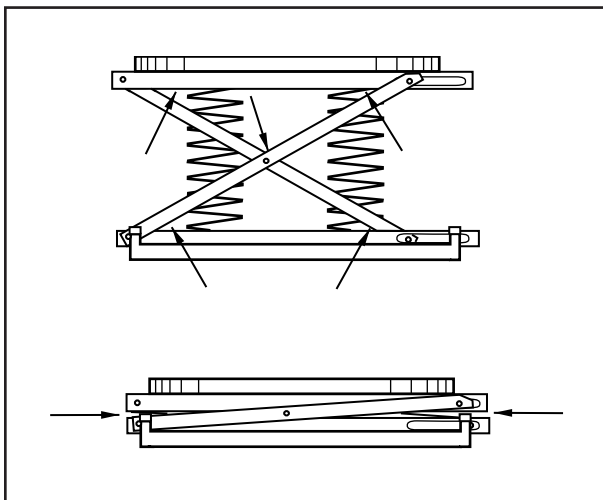

Fig. 2.
Pinch Points

WARNING!

Do not try to use this unit with damaged or broken pallets. Broken pallets may have boards or nails which hang down below the main part of the pallet. As the pallet is turned, these boards or nails may catch on the frame of the unit. This can cause the pallet to stop turning suddenly, causing the load to shift.

You may be injured, and the unit may be damaged. The boards or nails on the bottom of the pallet should not extend down more than 1/8 inch.

Operation Notes – Use with Fork Lift or Stacker (See "Operation Notes - Manual Use" on previous page)

You must take some special precautions when using a fork lift or stacker with the unit:

When loading using a fork lift or stacker –

WARNING!

When adding a load to the unit, lower the forks completely before removing the fork lift. The pallet must be completely supported by the PalletPal. If you do not do this, the load may be dropped when

you remove the fork lift. The unit or the load may be damaged, or you may be hurt. Figure 7 shows the correct way to load using a fork lift.

When unloading using a fork lift or stacker –

WARNING!

When removing a load from the unit, lift the load clear of the PalletPal before backing out the fork lift. If you do not do this, the top of the unit may jump up when you remove the fork lift. The unit or the load may be damaged, or you may be hurt. Figure 8 shows the correct way to unload using a fork lift.

When moving the PalletPal -

Do not move the PalletPal while it is loaded. This will damage the base frame of the unit. The pockets on the base frame are designed to support an unloaded PalletPal, they cannot support any extra weight.

Specifications

Load capacity	400 to 4500 lbs., depending on springs
Load size	50" wide x 50" long x 72" high (max.)
Length	45 1/4 inches
Width (base frame)	36 3/4 inches
Compressed height	9 1/2 inches
Extended height	27 3/4 inches
Rotating ring, outside diameter	43 5/8 inches
Rotating ring, inside diameter.....	40 5/8 inches
Adjustment for sloping floors	Can adjust for floor slope up to 1:25 using optional adjustable feet
Net weight	420 lbs., with (3) springs installed

Installation Instructions

Unpacking the Unit

1. Before you start to install the unit, check for local codes and ordinances which may apply. It is your responsibility to obtain any necessary permits.
2. Please read all of these instructions carefully. Be sure to read and understand all of the warnings.
3. Inspect the shipping pallet carefully for any damage which may have affected the unit. If you see signs of damage, tell the trucker. Also make a note of this on the shipping papers which you are asked to sign.
4. Choose the place where you want to use the unit. It is very important that the PalletPal be set up on a smooth

and flat surface. Check the floor surface carefully and make sure that it is free of all loose debris and dirt.

Using optional adjustable feet, the unit can compensate for a slightly sloping floor (1:25), but the surface must be smooth and solid.

CAUTION!

The unit must be installed on a smooth flat surface. If the floor is not flat, this can create stresses in the frame of the unit. The unit may not work properly, or parts of the unit may wear more quickly than they should. You may be hurt or the load may be damaged.

1. **Fill in the weight of a fully loaded pallet here:** _____
(Do not guess. Get actual weight from prospect or have a pallet weighed)¹
2. **Fill in the height of a fully loaded pallet here:** _____
(Do not guess. Get actual height from prospect or measure a loaded pallet)¹
3. **Using the chart below, select the correct PalletPal range:** _____

Weight of a Loaded Pallet (load & pallet) lbs.

	0-400#	400-800#	800-1200#	1200-1600#	1600-2000#	2000-2400#	2400-2800#	2800-3200#	3200-3600#	3600-4000#	4000-4500#
58 - 60"	0	0	1	1	1	1	2	2	2	3	3
56 - 58"	0	0	1	1	1	2	2	2	2	3	3
54 - 56"	0	0	1	1	1	2	2	2	2	3	3
52 - 54"	0	1	1	1	1	2	2	2	3	3	3
50 - 52"	0	1	1	1	1	2	2	2	3	3	4
48 - 50"	0	1	1	1	1	2	2	2	3	3	4
46 - 48"	0	1	1	1	1	2	2	3	3	3	4
44 - 46"	0	1	1	1	2	2	3	3	3	4	4
42 - 44"	0	1	1	2	2	2	3	3	4	4	4
40 - 42"	0	1	1	2	2	3	3	3	4	4	4
38 - 40"	0	1	1	2	2	3	3	4	4	4	4
36 - 38"	0	1	1	2	2	3	4	4	4	4	4
34 - 36"	1	1	2	2	3	3	4	4	4	4	---
32 - 34"	1	1	2	3	3	4	4	4	4	---	---
30 - 32"	1	1	2	3	3	4	4	4	4	---	---

¹Caution: PalletPal springs are precisely calibrated and will work best within the load weight and height ranges selected. Selection based on higher or lower than actual weight will result in restricted raising or lowering capability. Should pallet weight or height weight requirements dramatically change, PalletPal can be adapted in the field at any time by simply changing the spring combination

- Range 0** – Pallet Pal with white spring (special order)
- Range 1** – Pallet Pal with orange spring
- Range 2** – Pallet Pal with orange & gray spring
- Range 3** – Pallet Pal with orange & purple spring
- Range 4** – Pallet Pal with orange, gray & purple spring

¹Load range is available, consult Sales for details

Table 1 - Spring selection chart

5. Position the PalletPal beside the point where the unit will be set up.

WARNING!

The unit is attached to the skid using metal bands. These bands are under high tension. The edges are sharp. Wear safety glasses and gloves when you handle or cut the banding.

6. Remove the metal banding which secures the unit to the pallet. Remove all packing material. Shift the unit to the floor. Support the base as you do this.

7. Check to see that the frame of the unit is sitting firmly on the floor. Try to move or rock the frame of the unit. The base frame should be stable, and should not move. Check to see that the base frame is level. (If any part of the frame is more than 1/2" out of level in relation to any other part, you must install the optional adjustable feet to level the unit. See the instructions which follow.)

8. Remove the springs and lay them out on the floor.

9. If you have any questions about the steps in the installation process, please call Southworth Customer Service at 1-800-743-1000.

Installing the Optional Adjustable Feet

1. You will need two adjustable wrenches to install the feet. Each foot has a large threaded shaft which fits through one of the large holes in the base frame of the unit.

There are three nuts for each shaft. When each foot is installed, the threaded shaft should include one nut below the base frame and two nuts above it. Two of the nuts are used to clamp against the base frame. The third nut is used to lock the adjustment.

2. Adjust each of the feet until the frame of the unit is level. All four of the feet must touch the floor. Once the settings are correct, tighten two of the nuts against the base frame. The third nut (above the base frame) is used to lock the setting. Tighten this nut down against the nut below it.

Installing the Springs

1. The frame of the unit can handle loads of up to 4500 lbs. In order to adapt the unit for different pallet loads, the springs are changed. The springs are chosen to match the weight and height of a fully loaded pallet. A unit may have one to three springs.

Each time the pallet weight or pallet height is changed, the springs may also need to be changed. Table 1 and Table 2 on page 6 show how the springs are selected. Each spring is color-coded with paint mark at one end. Each Pallet Pal unit will always have at least one spring. This spring has an orange mark, and is larger in diameter than the others. This large orange spring is always placed near the rear of the unit, in the position closest to the hinge. Figure 4 shows the position of the first spring, and any additional springs which may be needed.

The turntable pivots on a hinge at the rear.

The largest spring (orange) is mounted near the rear of the unit.

The shock absorber is disconnected and laid to one side.

The maintenance pin must be removed from the upper end of the shock absorber and inserted into the side of the roller track



The rotator ring support frame should be handled by two workers.

NOTE: Rotator ring is removed.

The top of the spring should fit behind this guide tab.

The front of the table is released by removing the pivot shaft here.

The bottom of the spring will fit over the round support.

Fig. 3 Inserting the First Spring

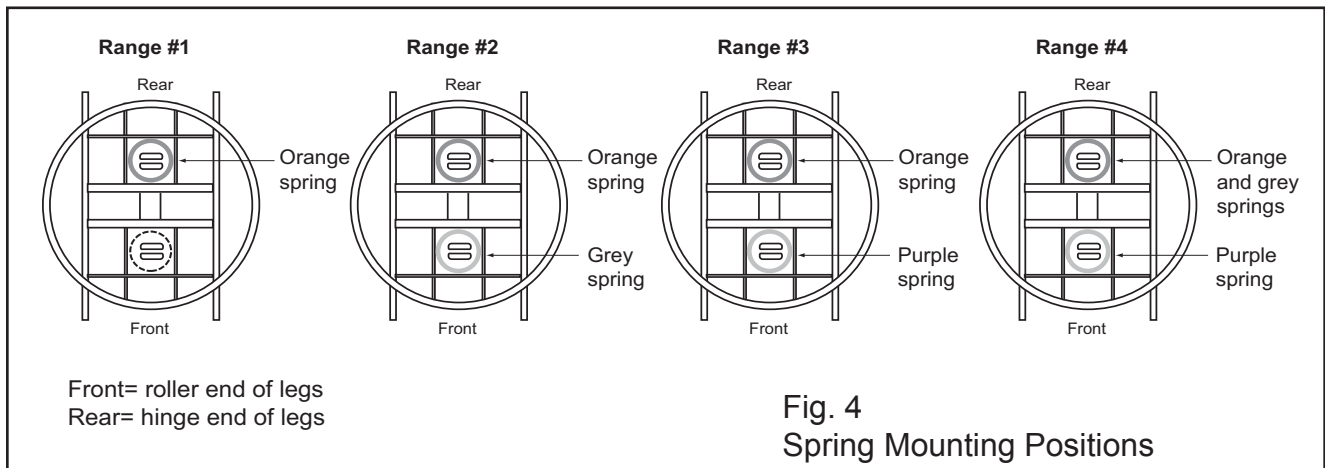

2. Double-check to be sure you have the correct springs. Calculate the weight of a fully-loaded pallet, including the pallet itself. Measure the height of a fully-loaded pallet. Refer to Table 1 and Table 2, and see that you have the correct springs for your application.

3. The unit is shipped without springs installed. The installation of the first spring (orange) requires two people.

4. Cut the cable ties and lift the rotating ring away from the top frame.

NOTE: The shock absorber is optional on the stainless steel model. If the shock absorber is not present use a screw driver as a maintenance pin to hold the unit in a raised position.

5. The shock absorber is attached to the frame of the unit with a pivot pin, and this is held in place by a linch pin. During maintenance, the pivot pint is used as a maintenance pin to hold the table frame in the raised position. Take a look at the mechanism and note the positions of the parts. Remove the linch pin and remove the pivot pin. Lay the free end of the absorber down.

6. With the help of an assistant, lift the top part of the frame as far as it will go. Insert the maintenance pin into the lower roller guide. See Fig. 3.

WARNING!

The maintenance pin is designed to hold the frame of the unit in a raised position while you insert the first spring. If you do not use the pin, it may be unsafe to insert the spring. The frame of the unit may drop suddenly and you may be hurt.

7. Free the front end of the table mechanism so you can tilt the table top back. The front end of the mechanism is held in place by a pivot shaft. This shaft supports two rollers and is secured by a linch pin. Remove the linch pin and slide the pin out. Note the positions of the parts.

8. Tilt the top frame assembly back as shown in Fig. 3. Begin by mounting the largest spring (orange mark).

This spring should be placed in the back of the unit, nearest the hinge. It does not matter which end of the spring is up. The bottom of the spring should fit over the round support on the base frame. The top should fit behind the small guide tab shown in Fig. 3. Once the spring is in place, slowly lower the table top mechanism. Check each end of the spring to be sure it has seated correctly.

9. Re-attach the pivot shaft at the front of the unit. Remember to place the roller wheels in the guide slots. Insert the linch pin to hold the pivot shaft in place.

10. The single orange spring will now hold the unit up. Re-attach the shock absorber by inserting the pivot pin and inserting the linch pin. Place the rotating ring back on the top frame. Check to be sure the ring can rotate freely.

Table 1 and Table 2 may indicate that one or two additional springs must be installed. To do this, remove the spring cap(s) and insert the spring(s) through the top of the unit. See Fig. 4 to check the placement. To remove a cap, turn it counter-clockwise and lift upward. Insert the spring through the opening. Again, it does not matter which end of the spring is up. Replace the spring lock cap and turn clockwise to lock it.

11. Before using the unit, make a safety check. Be sure that each of the spring lock caps is firmly in place. Check the top and bottom of each spring to be sure it is seated correctly. Check the linch pin at the top of the shock absorber, and the linch pin at the end of the pivot shaft. These checks are very important.

WARNING!

If the springs are not seated correctly, or the spring lock caps are not tightened, the parts may pop loose when the unit is used. You may be hurt or the load may be damaged.

Operating Instructions

Loading Manually

Add boxes or parts until the pallet is full. Load the pallet in layers. Use the rotating ring to position the pallet to eliminate walking around. The unit will gradually lower the pallet until it reaches the bottom. See Fig. 5.

CAUTION!

Rotate the pallet load. Never place your hands on the rotator ring. You may be hurt.

Fig. 5
Loading Manually

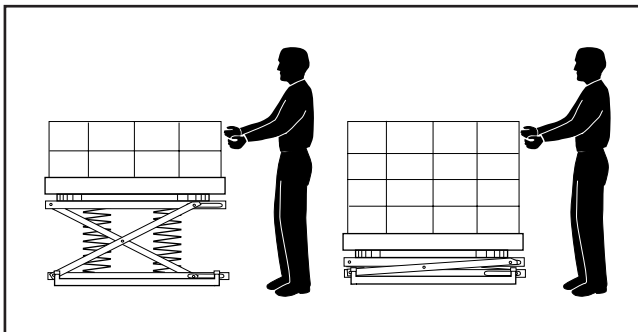

Removing Loads Manually

Remove boxes or parts until the pallet is empty. Unload the pallet in layers. Use the rotating ring to position the pallet to eliminate walking around. The unit will gradually raise the pallet. See Fig. 6.

Fig. 6
Unloading Manually

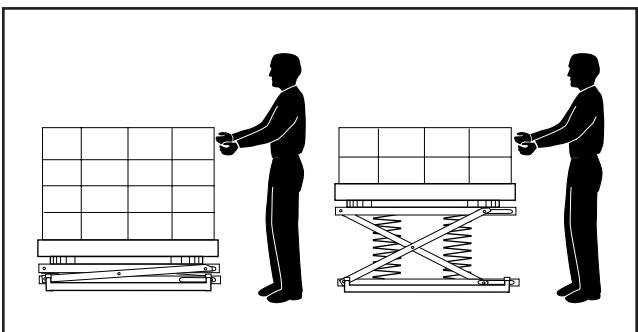

Operating Safety - Manual Use

1. Do not use this unit with a load greater than the rated load. This includes the weight of the payload and the weight of the pallet. Table 1 on page 6 shows how to be sure you have the correct spring combination for your application.
2. Never push the load off of the side of the unit. If you do this, the frame of the unit may jump upward.
3. Never use the unit when anyone is sitting or riding on the rotating ring.
4. Do not try to use this unit with damaged or broken pallets. Broken pallets may have boards or nails which hang down below the main part of the pallet. As the pallet is turned, these boards or nails may catch on the frame. The pallet may stop turning suddenly and this can cause the load to shift. You may be injured and the unit may be damaged. If the boards or nails on the bottom of the pallet extend down more than $\frac{1}{8}$ inch, they will interfere with the turning action.
5. Stay clear of the rotating ring when it is moving. As the pallet turns, a part of the load may rotate around and hit you.
6. Keep the area around the unit clean. Do not allow any dirt, debris, spilled oil, or excess grease to collect. These materials may cause you to slip while the unit is operating and you may be injured.

Loading with a Fork Lift

1. Place the load on the lift, then lower the fork lift. Before removing the load, be sure the unit is carrying the weight, not the fork lift. See Fig. 7.
 - Lower the load until the springs on the PalletPal are fully compressed.
 - Be sure the forks on the lift are clear of the inside of the pallet.

WARNING!

If you skip these steps, the load may drop suddenly when you remove the fork lift. You may be hurt or the unit or load may be damaged.

WARNING!

Never drop the load on the rotating ring. If you do this while the rotating ring is moving, the load may shift. You may be injured or the unit may be damaged. If you drop the load while the rotating ring is stopped, the unit may be damaged.

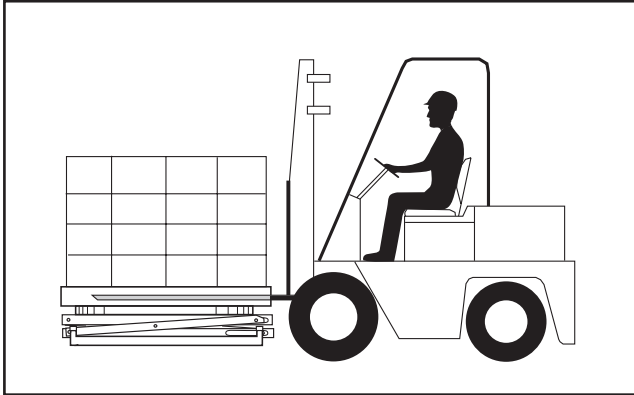

Fig. 7
Loading with a Fork Lift

2. Be sure the load is centered on the unit.

WARNING!

If the load is off-center, it may shift when the rotating ring is turned. You may be hurt or the unit or load may be damaged.

Unloading with a Fork Lift

1. Insert the forks fully into the pallet, and lift the pallet straight up and clear of the top of the unit. See Fig. 8.
- Raise the pallet until the springs on the PalletPal are fully extended.
 - Be sure the pallet clears the top of the rotating ring before you move the fork lift.

WARNING!

If you skip these steps, the unit may jump up suddenly when you remove the pallet. You may be hurt or the unit or load may be damaged.

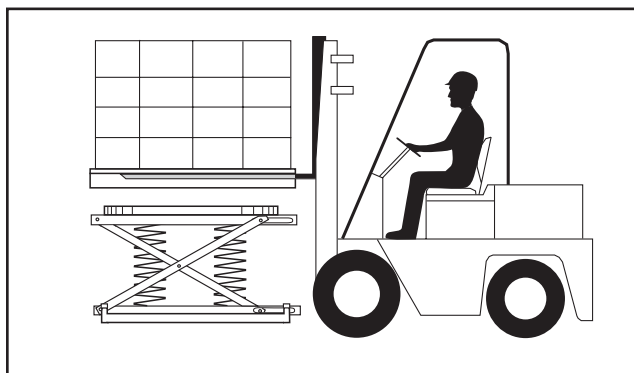

Fig. 8
Unloading with a Fork Lift

Moving the Pallet Pal

CAUTION!

Do not move the Pallet Pal while it is loaded. This will damage the base frame of the unit. The pockets on the base frame are designed to support an unloaded PalletPal, but cannot support any extra weight.

1. Remove any load from the top of the Pallet Pal.
2. Insert the forks into the pockets in the base frame. See Fig. 9.

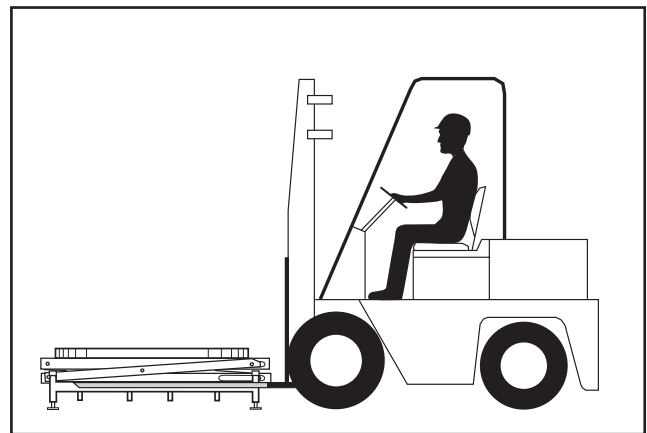

Fig. 9
Moving the Pallet Pal

Maintenance

Routine Periodic Maintenance

Every 90 days -

- Check for loose hardware and signs of excessive wear. On the models where the shock absorber is used, check for signs of leakage.
- Check to be sure that the unit is placed on a firm level surface. If the optional feet are installed, be sure that all four feet are touching the floor and are locked in position.

Troubleshooting

Troubleshooting Check List

Problem	Possible Cause	Check This
The unit lowers too easily (too early).	The spring combination may be too weak for the load.	Check the spring ratings. See Table 1 on page 7.
The unit does not lower enough (too late).	The spring combination may be too strong for the load.	Check the spring ratings. See Table 1 on page 7.
The top of the unit rotates away from you.	The frame of the unit may not be level.	Move the unit to a level surface or install the optional adjusting feet.
The top of the unit bounces.	The shock absorber may be damaged.	Check for leaks or dents. Replace if damaged.
Excessive "rumble" when the ring rotates	Wear or lack of lubrication to bearings under rotating ring.	Remove turntable, lubricate or replace bearings.
Wear or metal flaking from underside of rotating ring.	Normal condition caused by work-hardening of metal.	No repair necessary. This will stop once the rotator ring wears in.

Ordering Replacement Parts

Southworth has carefully chosen the components in your unit to be the best available for the purpose. Replacement parts should be identical to the original equipment. Southworth will not be responsible for equipment failures resulting from the use of incorrect replacement parts or from unauthorized modifications to the unit.

Southworth can supply all replacement parts for your PalletPal. With your order, please include the model number and the serial number of the unit. You can find these numbers on the name plate. This plate is located within the scissors mechanism.

To order replacement parts, please call the Parts Department at (207) 878-0700 or (800) 743-1000. Parts are shipped subject to the following terms:

- FOB factory
- Returns only with the approval of our Parts Department.
- Payment net 30 days (except parts covered by warranty).
- Freight collect (except parts covered by warranty).

Parts replaced under warranty are on a “charge-credit” basis. We will invoice you when we ship the replacement part, then credit you when you return the worn or damaged part.

Parts Department
Southworth Products Corp.
P.O. Box 1380
Portland, Maine, 04104-1380
Telephone: (800)743-1000 or (207)878-0700
FAX: (207)797-4734
Service@SouthworthProducts.com

2 YEAR WARRANTY

Southworth Products Corp warrants this product to be free from defects in material or workmanship for a period of **2 years** of single shift usage from date of shipment, providing claim is made in writing within that time period. This warranty shall not cover modified designs for special applications, failure or defective operation caused by misuse, misapplication, negligence or accident, exceeding recommended capacities, failure to perform required maintenance or altering or repairing, unless alteration is authorized by Southworth Products Corp. Except as set forth herein, there are no other warranties, express or implied, including the warranties of merchantability and fitness for a particular purpose, all of which are hereby excluded.

Southworth Products Corp makes no warranty or representation with respect to the compliance of any product with state or local safety or product standard codes, and any failure to comply with such codes shall not be considered a defect of material or workmanship under this warranty. Southworth Products Corp shall not be liable for any direct or consequential damages arising out of such noncompliance.

Southworth Products Corp's obligation under this warranty is limited to the replacement or repair of defective components at its factory or another location at Southworth Products Corp's discretion. This is buyer's sole remedy. Except as stated herein, Southworth Products Corp will not be liable for any loss, injury or damage to persons or property, nor for direct, indirect, or consequential damage of any kind, resulting from failure or defective operation of said product.

This warranty may be altered only in writing by Southworth Products Corp, Portland, Maine.

SOUTHWORTH PRODUCTS CORP

P.O. Box 1380, Portland, ME 04104-1380
Telephone: (800) 743-1000 • (207) 878-0700
Fax: (207) 797-4734
www.SouthworthProducts.com

SOUTHWORTH

We'll Show You How

Southworth is the world class supplier of products designed to improve productivity and enhance safety. Our staff has over 400 years of engineering experience. If one of our standard products does not meet your needs, our engineers can custom design equipment specifically suited to your material handling application.



Spring PalletPal Load Leveler



Lift with Flush Mount Turntable



Portable Container Tilters



Dock Lifts



Roll on Level Loaders



Portable Lifts



Stretchwrapping



Positioning

Floor to Mezzanine Lifts



Pallet Rotators



For more information, contact Southworth Products

Telephone (800) 743-1000 Fax (207) 797-4734

Email: salesinfo@SouthworthProducts.com