

**SOUTHWORTH**  
making work faster, safer, and easier

# PML Transpositioner

**Maintenance Manual  
& Operator Instructions**

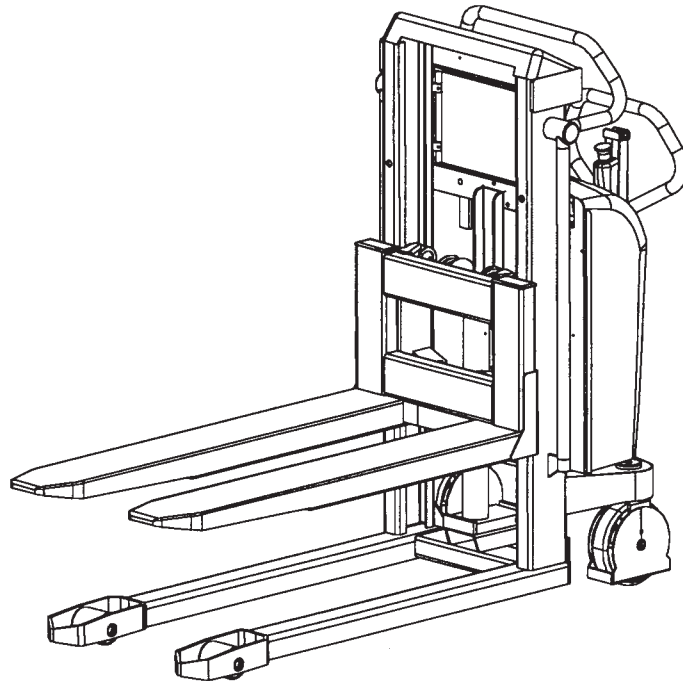

Model # \_\_\_\_\_

Serial # \_\_\_\_\_

**SOUTHWORTH PRODUCTS CORP**  
P.O. Box 1380 • Portland, ME 04104-1380  
Telephone: (207) 878-0700 or (800) 743-1000  
Fax: (207) 797-4734

Revised May 2011

The PML Transpositioner is manufactured in accordance with ANSI Standard B56.10 and PREN 1757-1.

AMONG THE SUBJECTS DEALT WITH IN THIS MANUAL ARE:

- *Proper application*
- *Physical limitations of the product*
- *Risks with improper use*

**Therefore please read this Owner's Manual carefully!**

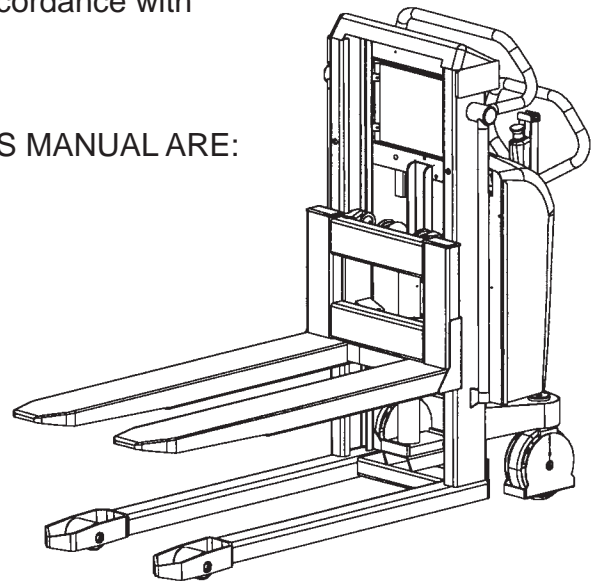

## Unpacking the PML Transpositioner

### Lifting procedure

When lifting the product, please use a cable sling, with the appropriate lifting device.

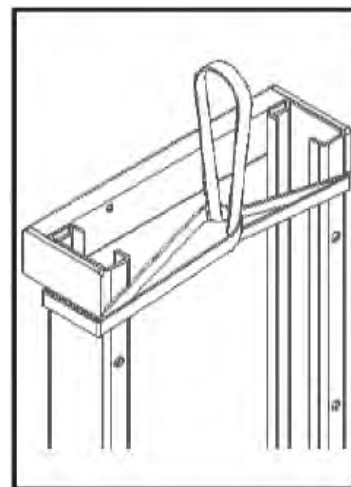

## Contents

### SECTION ONE -- MAINTENANCE MANUAL

INTRODUCTION .....	4
SAFETY .....	4
How to operate the PML transpositioner .....	6
Avoid overloads. Avoid offset loads .....	7
Operator precautions .....	9
THE BATTERY .....	10
Preparing to charge the battery .....	10
Precautions for grounding .....	10
Battery charging precautions and warnings .....	11
Battery maintenance .....	11
ELECTRICAL .....	12
Fuse replacement .....	12
Wiring connections .....	13
LUBRICATION AND HYDRAULIC OIL .....	14
Oil Change .....	14
ADJUSTMENTS .....	15
Fork adjustments .....	15
Adjustments of lifting chains .....	15
Adjustment of steering wheel chain .....	15
Bleeding the hydraulic system .....	15
Adjustment of the side play .....	16
Adjustment of brake .....	17
Adjustment of pad .....	18
Black top cap installation .....	19
CLEANING .....	20
Cleaning of the plastic screen .....	20
TROUBLESHOOTING .....	20
ORDERING REPLACEMENT PARTS .....	21
RECOMMENDED SPARE PARTS .....	22

### SECTION TWO -- OPERATOR'S INSTRUCTION MANUAL

OPERATOR INSTRUCTIONS .....	37
2 YEAR WARRANTY .....	BACK COVER

### List of Figures and Tables

PML-30ME Chassis and parts list .....	23-24
LL 1001 MS Chassis and parts list .....	25-27
PML-30-ME Electric Hydraulic pump .....	28-29
PML-30-ME Charger .....	30
PML-30-ME Relay and Fuses .....	31
PML-30-ME Steering gear .....	32-33
Wiring Diagram Main Current .....	34
Electrical Wiring Diagram Main Current .....	35
Electrical Wiring Diagram Control Current .....	36

## Introduction

This manual contains instructions on the safe and proper installation, use, and maintenance of a PML Transpositioner unit. Be sure that this manual is available to the people who install, use, or service the unit. Be sure that all personnel read this manual before they install, use, or service the unit.

PML Transpositioner units may be used in a wide variety of industrial settings. The instructions in this manual are not necessarily all-inclusive, as Southworth cannot anticipate all conceivable or unique situations. *In the interest of safety, please read this whole manual carefully. Please understand the material in this manual before you install, use, or service the PML Transpositioner. If you have any questions about any of the instructions in this manual, please contact Southworth Products Corp.*

Southworth's product warranty is shown on the back cover of this manual. This instruction manual is *not intended to be or to create any other warranty, express or implied, including any implied warranty of merchantability or fitness for a particular purpose, all of which are hereby expressly excluded.* As set forth more specifically in the product warranty, Southworth's obligation under that warranty is limited to the repair or replace-

ment of defective components, which shall be the buyer's sole remedy, and Southworth shall not be liable for any loss, injury, or damage to persons or property, nor for any direct, indirect, or consequential damage of any kind resulting from the PML Transpositioner.

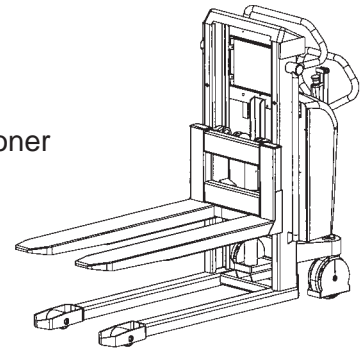

The PML Transpositioner is manufactured in accordance with ANSI Standard B56.10 and PREN 1757-1.

Among the subjects dealt with in this owner's manual are:

- *Proper application*
- *Physical limitations of the product*
- *Risks with improper use*

**Please read this Owner's Manual carefully!**

## Safety

The safety of all persons installing, using, servicing, or working near the PML Transpositioner is of paramount concern to Southworth. The PML Transpositioner unit is a powerful machine with moving parts, and is capable of causing personal injury if proper precautions are not taken.

Therefore, throughout this manual, Southworth has identified certain hazards which may occur in the use of the PML Transpositioner, and provided appropriate instructions or precautions which should be taken to avoid these hazards. In some cases, Southworth has also pointed out the consequences which may occur if Southworth's instructions or precautions are not followed. Southworth uses the following system of identifying the severity of the hazards associated with its products:

**DANGER – Immediate hazard which will result in severe personal injury or death.**

**WARNING – Hazard or unsafe practice which could result in severe personal injury or death.**

**CAUTION – Hazard or unsafe practice which could result in minor personal injury or property damage.**

Please read and follow this instruction manual, including all safety instructions and precautions, carefully and completely.

NOTE: To ensure premature wear does not occur to the brake arm, pull up and push forward to release the brake, or pull up and pull back to set the brake.

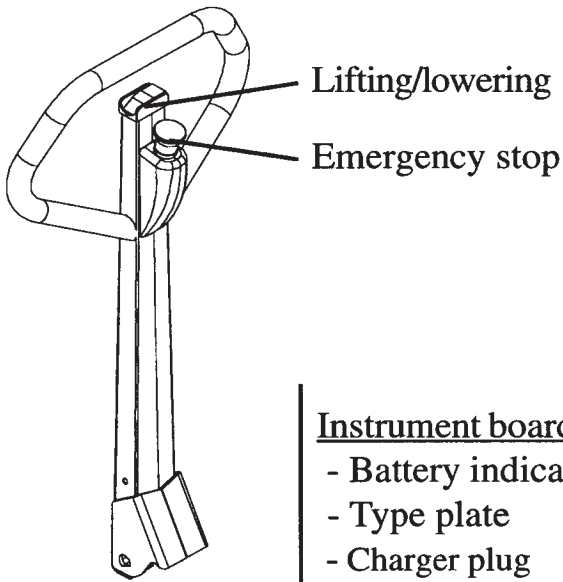

**Instrument board:**

- Battery indicator
- Type plate
- Charger plug (internal or external charger)
- Plug for extra equipment, 12V, max. 15Amp

Released position

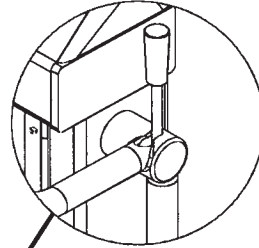

Braked position

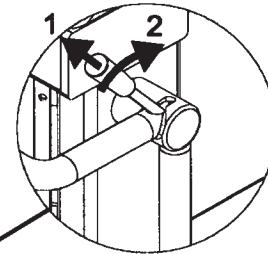

To release:  
**1. Pull**  
**2. Push**

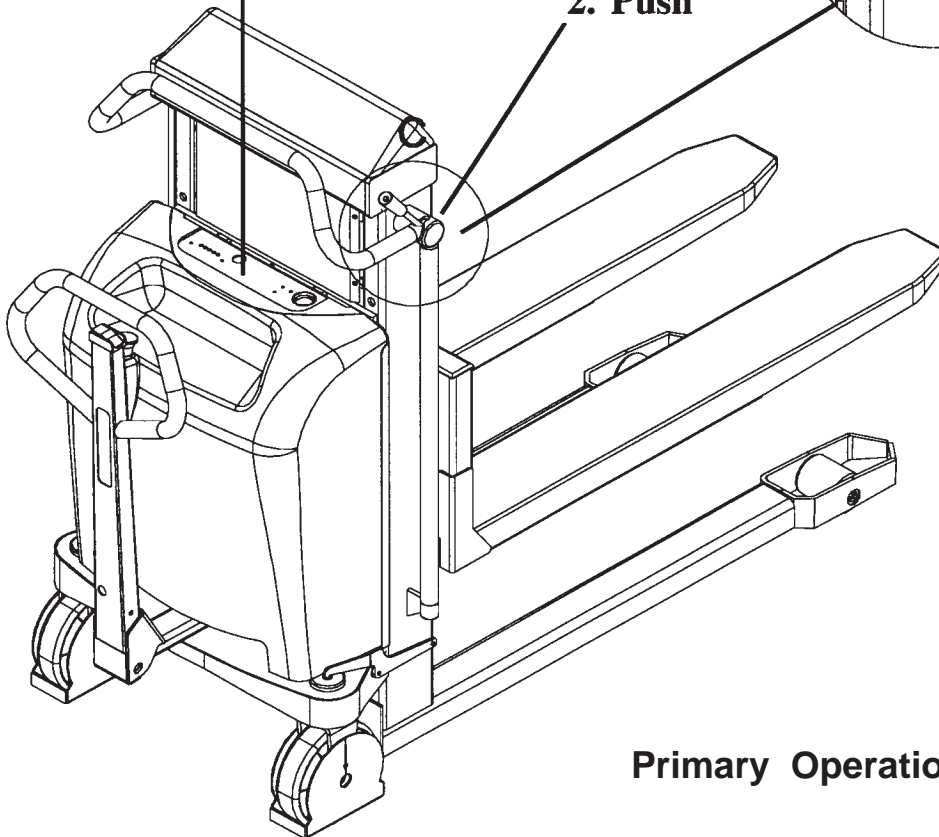

**Primary Operation Functions**

# How to operate the PML Tranpositioner

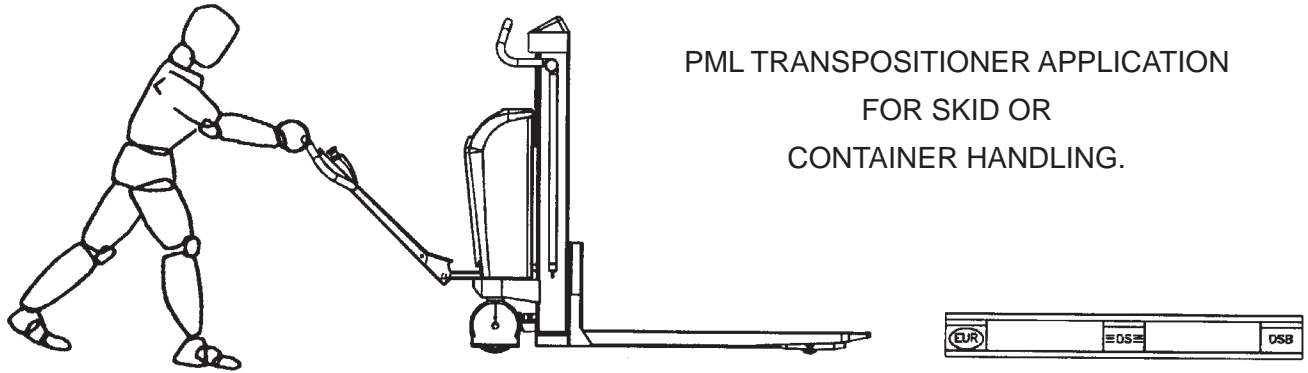

For proper operation,  
stand behind the handle.

Push/pull - raise/lower

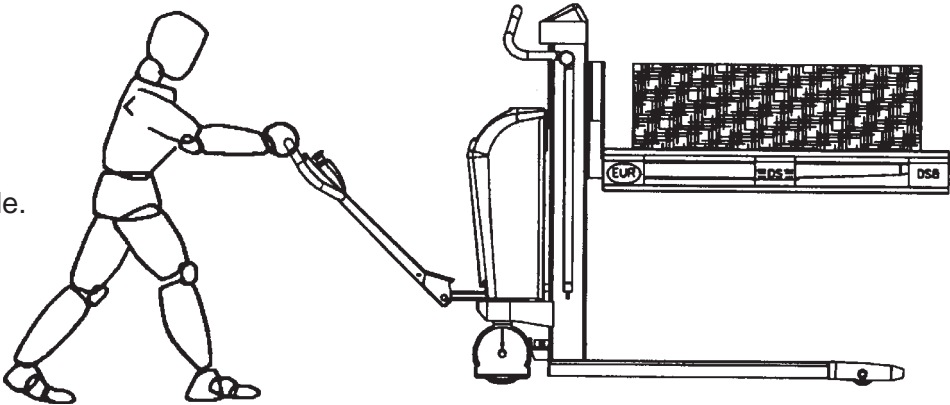

## Optimum safety

### Avoid overloads

The maximum load must not be exceeded. Remember, that the PML Transpositioner is designed for evenly distributed load, - goods on pallets etc. If the forks are point-loaded on one side there is a risk of bending.

### Avoid offset loads

The load must be distributed **evenly** on pallets or similar, - with a maximum distance of 24 in. between centre of gravity and mast front. A greater distance reduces the level of safety and increases the risk of toppling. Goods on pallets, etc. must be properly secured so that they can not fall off during transport, when the truck is lifted, or when the truck must remain elevated for a time.

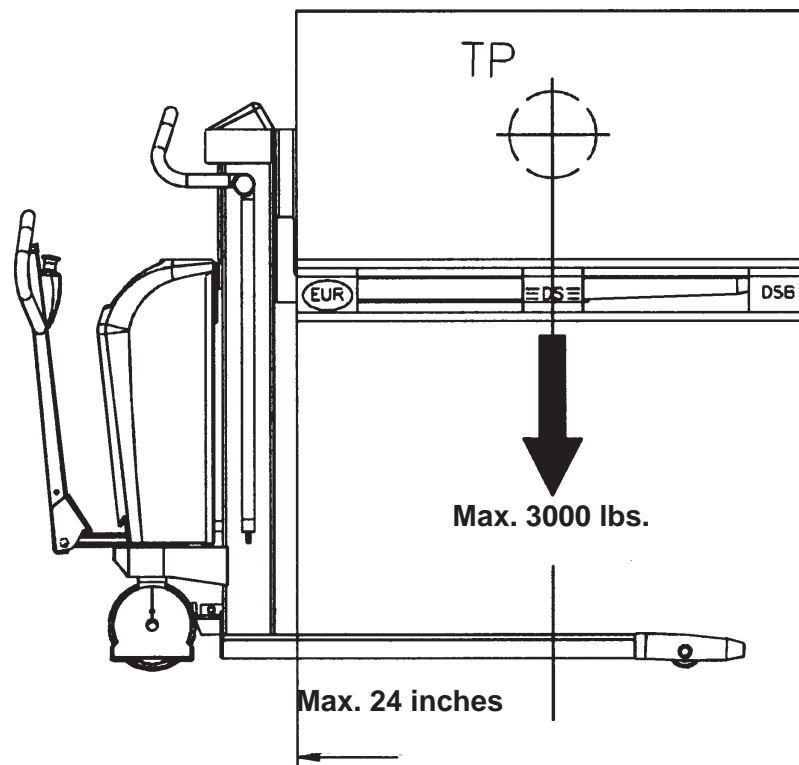

WARNING:

**ATTENTION  
MOVING PARTS**

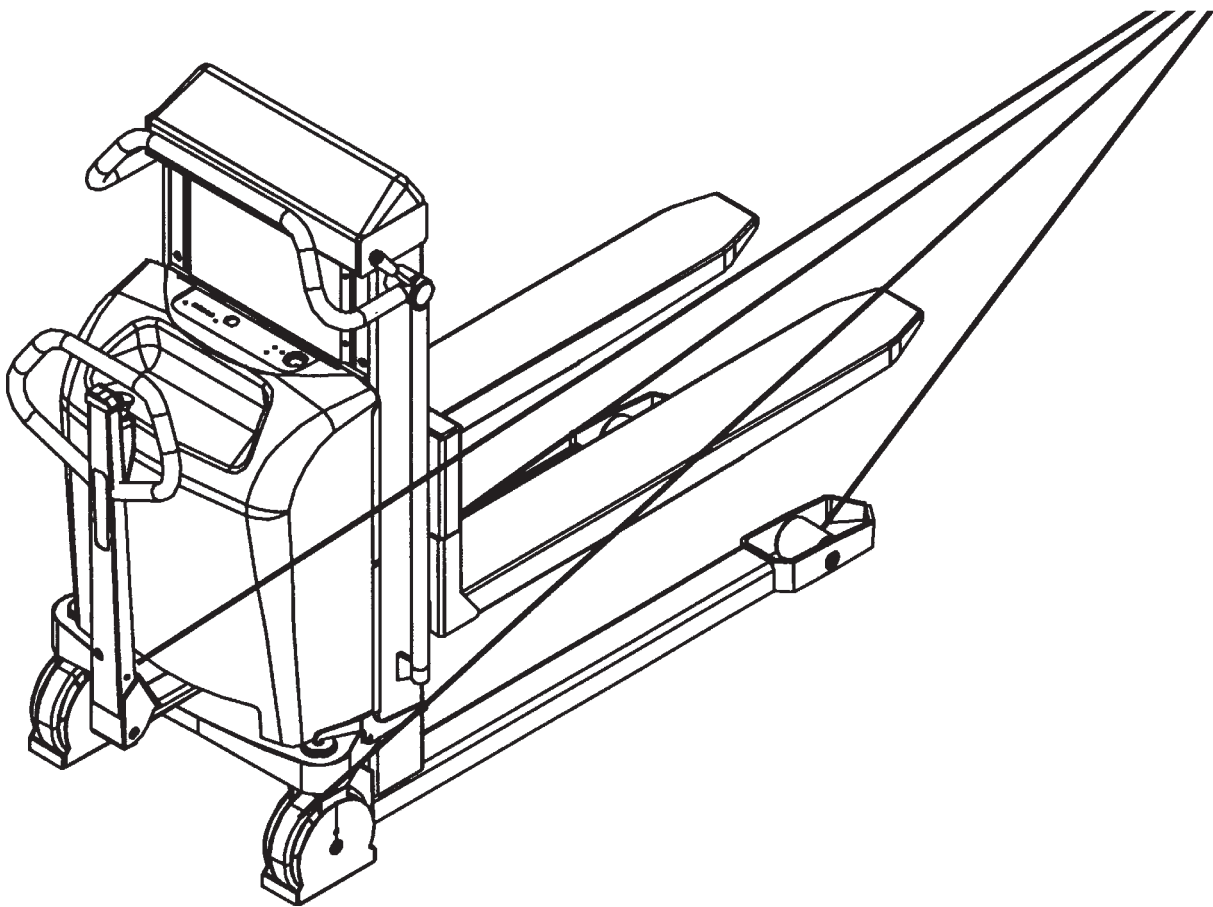

**Operator Precautions**



**Max. 2750 lbs.**

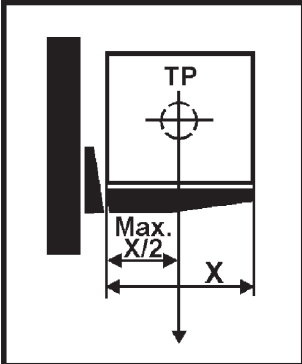

**CAUTION:**

- Never walk under a raised load!
- Before lowering the forks, make certain that no foreign objects can hinder the free lowering of the forks.
- The Transpositioner is designed for use on even and level floor.
- During transport the forks shall be raised as little as possible.
- Transport with raised forks should be made over the shortest possible distances and at low speed.
- Check that the chains lift equally. They shall be equally tight when the forks are loaded.
- Chains and chain bolts must not be damaged. Chains that have become permanently stretched (max. 2% of original length) must be replaced.

**Max. 2750 lbs.**

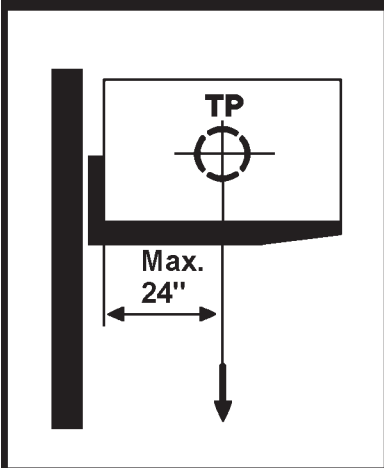

**Capacity Label**

The mast lifting capacity and the corresponding center of gravity distance are given by the label on the side of the mast.

Maximum lifting capacity is pre-set on the relief valve of the product.

## Preparing to charge the battery

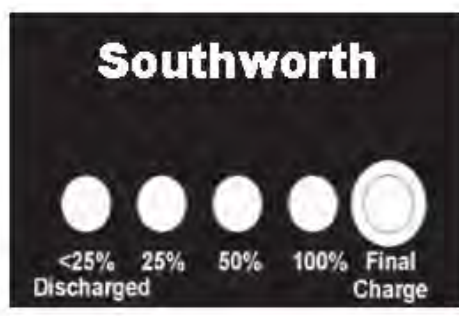

### BATTERY INDICATOR

The battery indicator shows the battery charge in %. The most accurate reading can be obtained, when the battery has not been used for 5-10 minutes.

- Red:** Battery capacity: below 25% Discharged  
Do not use the product, as the battery can be permanently damaged.
- Green:** Battery capacity: 25% - 100%  
The product is ready for use and need not be charged.
- Yellow:** Charging lamp: Is lit during the last part of the charging.
- Final charge:** Indicates full charge

### PRECAUTIONS FOR GROUNDING AND AC POWER CORD CONNECTION

Charger should be grounded or have an insulated case to reduce risk of electric shock. If the charger is equipped with an electric cord having an equipment-grounding conductor and grounding plug (three prong plug). The plug must be plugged into an outlet that is properly installed and grounded in accordance with all local codes and ordinances.

**DANGER – Never alter the AC cord or plug provided. If it will not fit the outlet, have the proper outlet installed by a qualified electrician. Improper connection can result in a risk of an electric shock.**

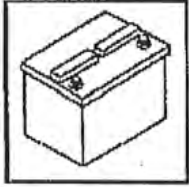

## BATTERY CHARGING

Charging must be performed with the charger that is provided and prewired into the machine. During charging, the temperature in the battery must not exceed 120° F. Charging simultaneously with truck operation is not recommended. Plug the charger into a 115V outlet. Charge until the battery gauge indicator lights show fully charged (approximately 6-8 hours).

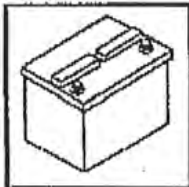

## WARNINGS AND INFORMATION ON BATTERY

Avoid the use of open flame batteries. At temperatures around the freezing point, battery capacity is reduced by 30%. The battery terminals, connections and wiring should be clean and free of corrosion. When cleaning any of these components wear a face shield or other suitable protective eyewear.

Read, understand and follow all battery and battery charger manufacturer's specific precautions while working with and/or charging batteries. The battery used in this machine is an AGM (Absorbed Glass Mat) type and allows safe trouble-free performance. There is no need to add electrolyte. No special handling is required and it is classified as non-hazardous.

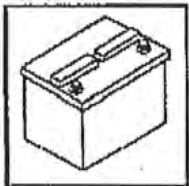

## BATTERY MAINTENANCE:

To measure the voltage, use a voltmeter (DC) on the battery poles. The truck must not have been in use for the previous 30 minutes.



Approx. 12.7 V	Fully charged
Approx. 12.2 V	1/2 charged
Approx. 12.0 V	1/4 charged
Approx. 11.6 V	Discharged

**WARNING: IF THESE INSTRUCTIONS ARE NOT CLEAR  
OR IF THERE ARE ANY QUESTIONS,  
PLEASE CONTACT SOUTHWORTH PRODUCTS CORP**

Telephone 1-800-743-1000 or Fax 207-797-4734

E-mail: [service@SouthworthProducts.com](mailto:service@SouthworthProducts.com)

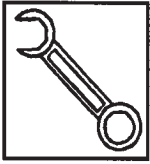

## FUSES - replacement

There are four fuses in the electrical circuit.

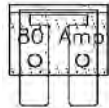

80 Amp fuse in the main supply from battery

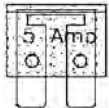

5 Amp fuse in the control current circuit

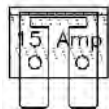

15 Amp fuse  
(plug for extra equipment on the instrument board)

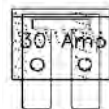

30 Amp fuse for built-in charger

**Do not insert a larger fuse; The fuse acts as a protector for the pump motor.**

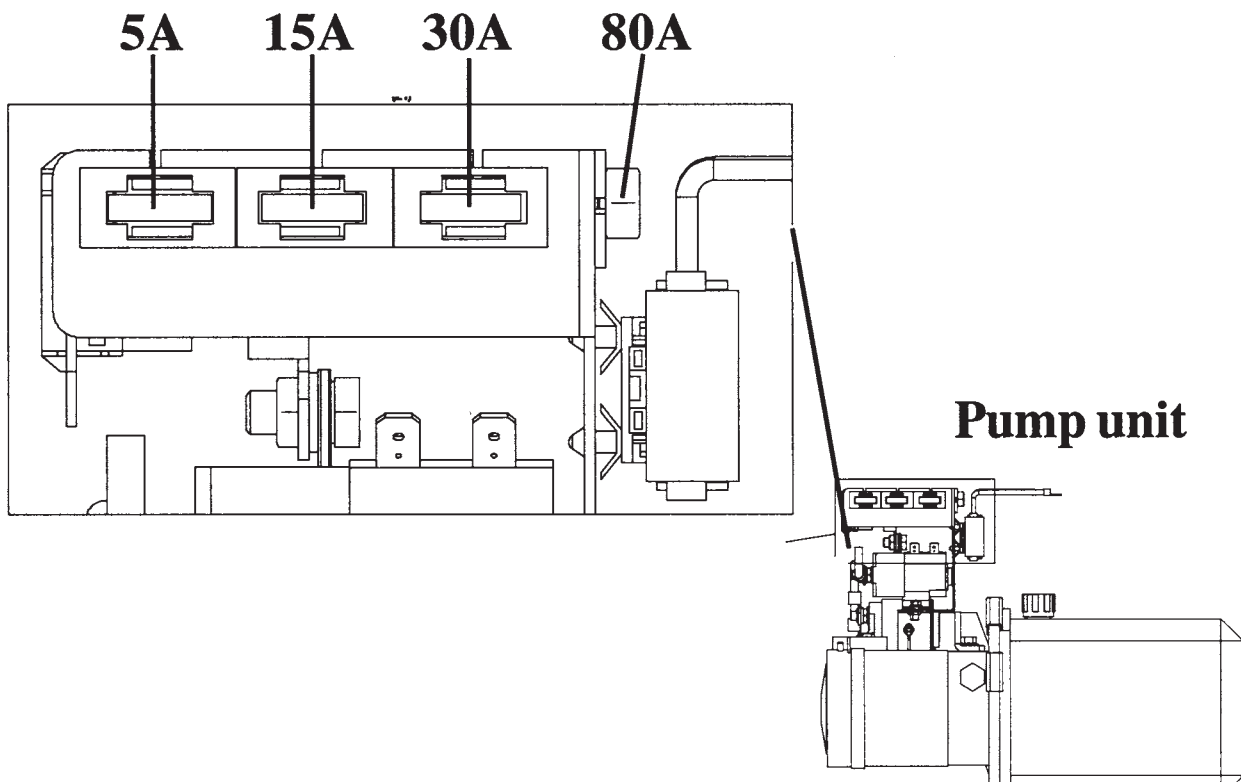

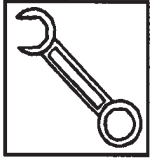

## WIRING CONNECTIONS

**Many operational problems are caused by poor connections in the electrical circuit. Make sure that the connections are clean and tight.**

Check connections regularly for damage at insulating caps or bad connections at plugs, etc. Keep all screw/nut connections tight.

Regular inspection and the replacement of worn or defective parts in good time will prolong the life of the Transpositioner.

“Prevention is better than repair”, therefore ensure:

- Correct usage
- Regular cleaning
- Periodic safety inspection
- Regular adjustment



## Lubrication and hydraulic oil

Under normal operation conditions the PML Transpositioner requires no lubrication.

All ball bearings are sealed and lubricated for life, and moving parts have self-lubricating bearings or are treated with molybdenum disulphide grease.

The hydraulic system is filled with hydraulic oil of viscosity (class ISO VG 32. ) non detergent 10W motor oil. An additive is added to the oil: Wynn's Hydraulic Systems Concentrate.

The concentrate reduces friction and wear and protects against corrosion. Pre-mixed hydraulic oil with additive is available from the dealer. The oil is suitable for use in the temperature range 14° to 120° F. A thinner oil is recommended for temperatures lower than 14° F (if necessary, contact your dealer).

### Tools Required for Maintenance:

- 1) Metric Allen Wrench Set
- 2) Metric Socket Set/Wrench Set
- 3) Philips Screw Driver



## Oil change

### Draining the oil:

1. Bring the unloaded forks down to the lowest position.
2. Most of the oil can be drained by loosening the hydraulic hose union and briefly activating the hydraulic pump with the switch.
3. The remaining oil can be drained from the oil tank by taking off the twelve clips on the pump and removing the tank.

### Oil filling:

4. Fill oil through the filling hole on the tank.
5. Oil quantity: 1.5 quarts. Use 10W non-detergent motor oil.
6. Fill oil to the bottom arrow (LogiLift) on the tank.
7. Refit the filling cap and bleed the system.

## Fork adjustment

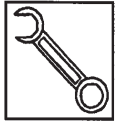

Two rollers on the fork bracket are mounted on eccentric pins so that they can be adjusted. The adjustable rollers are at the top.

### Adjustment:

1. Loosen screws pos. 91 (key width 3/16 of an inch).
2. Pin (pos. 56) can now be turned to give the necessary adjustment (key width 5/16 of an inch).
3. To ensure the same load on all rollers, adjustment must be made on both sides.

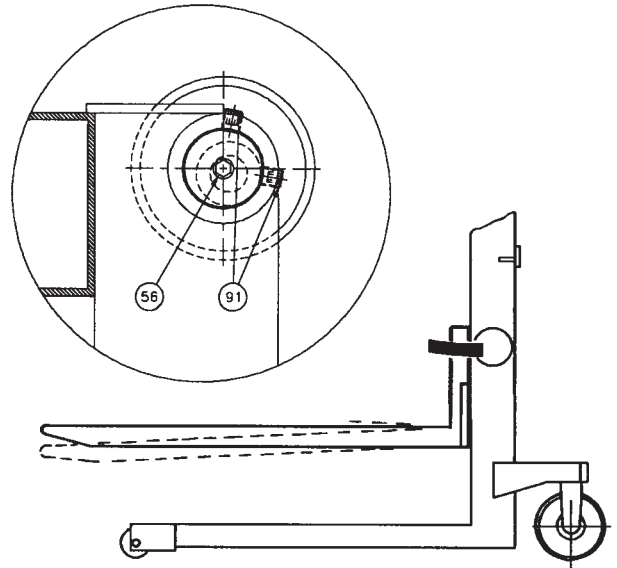

## Adjustment of lifting chain

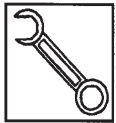

The chains shall be adjusted, so that they lift equally and be equally tight. The nuts (pos. 18) are to be adjusted (nut M12, key width 3/4 of an inch). On straddle versions, the chains are to keep the forks clear of the floor.

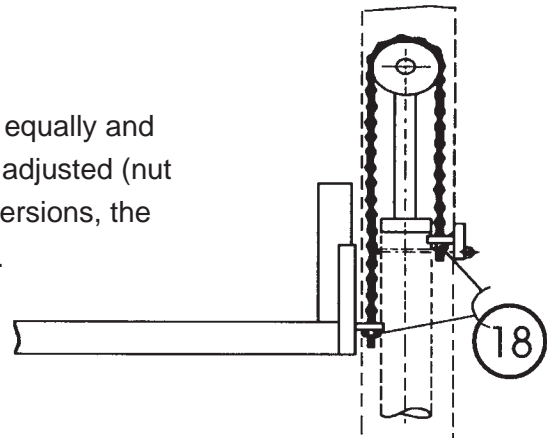

## Adjustment of steering wheel chain



- Set the handle in its middle position.
- Adjust nuts (1, 2, 3 and 4) and bring the wheels into parallel.

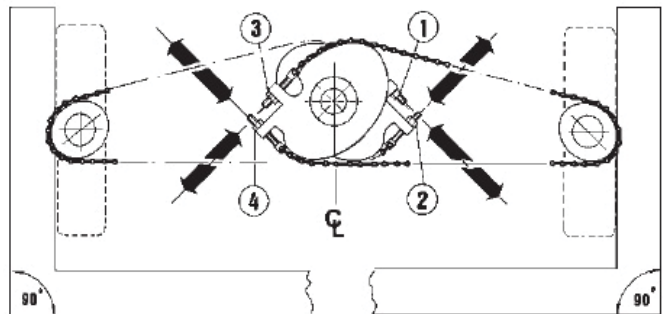

## Bleeding the hydraulic system

With a load of 110 - 220 lbs, the forks must be raised and lowered to top and bottom position 2-3 times.

## Adjustment of side play

(in the mast rolls of the right side of the fork bracket)

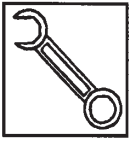

1. Screw (A) is loosened counter-clockwise, until resistance disappears.
2. Turn the screw clockwise, until resistance appears. The following 1.5 to 2.5 turns of the screw will be a tightening of the spring (C).
3. When a larger resistance appears, make 0.25 turn counter-clockwise, and the counter nut (B) will be tightened.
4. Pump the fork to its top position, and when lowering it has to slide to the bottom.  
If this is not the case, loosen screw A, make c. 0.5 turn counter-clockwise and repeat point 4.

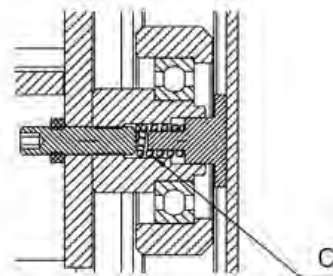
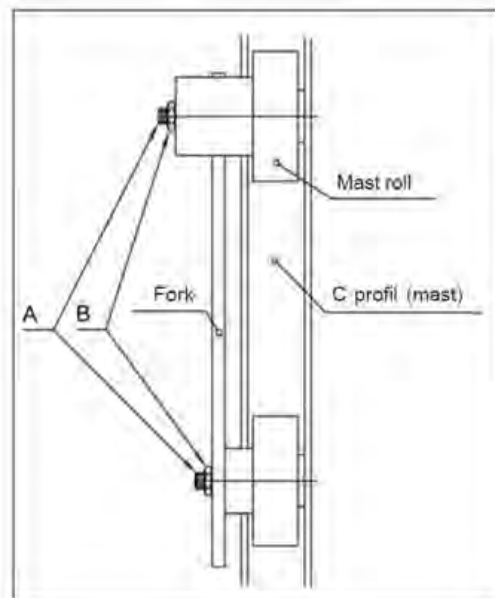

## Brake Adjustment

(Cable and Arm adjust should be looked at first.)

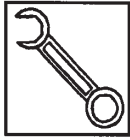

### Cable and Arm:

1. Tighten the adjusting nut at the bottom of the cable and spring to increase the tension on the brake and handle.

-- Loosen the nut to decrease tension.

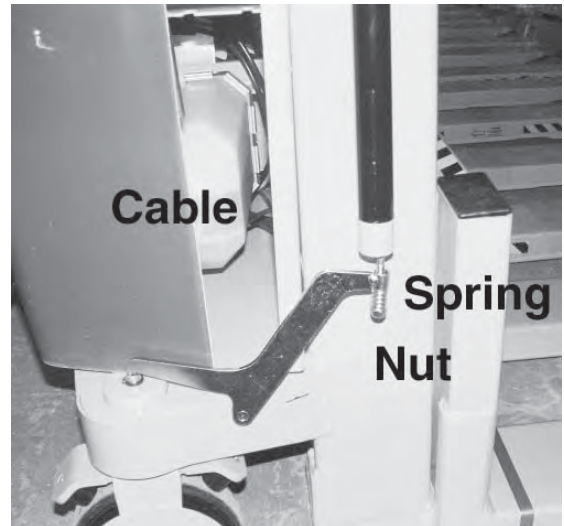

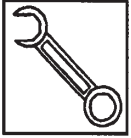

### **Pad Adjustment:**

1. Loosen the nut (under side of the brake plate) on the brake pad shaft.
2. Turn the brake pad counter clockwise until the pad is approximately 1/8" away from the caster.
3. Tighten the nut against brake plate to hold in place.

-- Both pads should be adjusted equally.

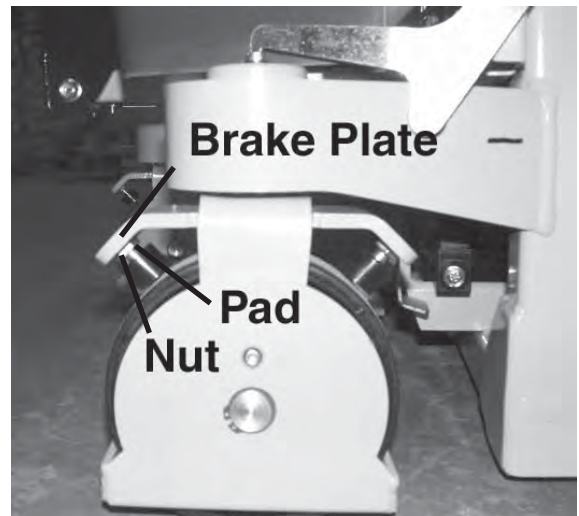

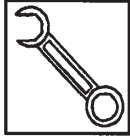

## The black top cap installation

The black top cap will be inside the Pallet Mobile Lifter for shipping Purposes.

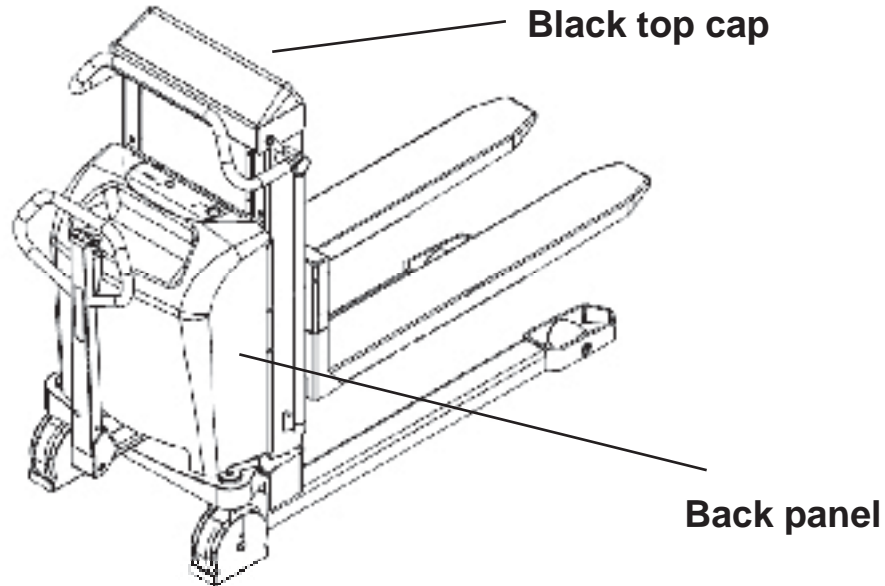

1. Remove the black top cap from the inside the back panel of the Pallet Mobile Lifter.
2. You will need to make sure the mounting brackets are turned to the up position.



3. The top cap will then need to be attached to the mounting brackets using the supplied screws.

## **Cleaning**

When cleaning the PML Transpositioner, do not direct the water jet onto bearings and seals, as the grease will be washed out and the life of the equipment shortened.

## **Cleaning of the plastic screen (polycarbonate)**

The screen is to be washed with slightly warm water adding a neutral cleaning material, and afterwards washed with clean water. Use a soft sponge, and a soft cotton cloth. Do not use paper towels.

*Never use sharp objects or solvent cleaners when cleaning.*

## **Troubleshooting**

When the PML Transpositioner is used every day, adjustments and the replacement of worn parts might be necessary.

If a fault appears during daily operation of the PML Transpositioner, first check:

- Oil supply
- Electricity supply
- Condition of leads and fuses

If faults cannot be traced to these sources, contact Southworth Products Corp's Service Department at 800-743-1000.

## Ordering Replacement Parts

Southworth has carefully chosen the components in your unit to be the best available for the purpose. Replacement parts should be identical to the original equipment. Southworth will not be responsible for equipment failures resulting from the use of incorrect replacement parts or from unauthorized modifications to the machine.

Southworth can supply all replacement parts for your Southworth PML Transpositioner. Key parts are identified in this manual.

With your order, please include the model number and the serial number of the unit. You will find these numbers on the name plate.

To order replacement parts, please call the Parts Department at (207) 878-0700. Parts are shipped subject to the following terms:

F.O.B. factory.

Returns only with the approval of our Parts Department.  
Restocking charges may apply.

Payment net 30 days (except parts covered by warranty).

Freight collect (except parts covered by warranty).

Parts replaced under warranty are on a "charge-credit" basis. We will invoice you when we ship the replacement part, then credit you when you return the assumed substandard part.

PARTS DEPARTMENT  
SOUTHWORTH PRODUCTS CORP  
PO Box 1380  
Portland, ME 04104-1380

Telephone: (207) 878-0700 or 1-800-743-1000

Fax: (207) 797-4734

[repairparts@SouthworthProducts.com](mailto:repairparts@SouthworthProducts.com)  
[www.SouthworthProducts.com](http://www.SouthworthProducts.com)

## **Recommended Spare Parts for the PML Transpositioner**

Cylinder Kit.....	Call Parts Dept.
Solenoid Valve .....	Call Parts Dept.
Starter Switch.....	Call Parts Dept.
5 AMP Fuse.....	Call Parts Dept.
15 AMP Fuse.....	Call Parts Dept.
30 AMP Fuse.....	Call Parts Dept.
80 AMP Fuse.....	Call Parts Dept.
Tilting Switch with Holder .....	Call Parts Dept.
Emergency Stop Switch .....	Call Parts Dept.

PML-30ME

Chassis

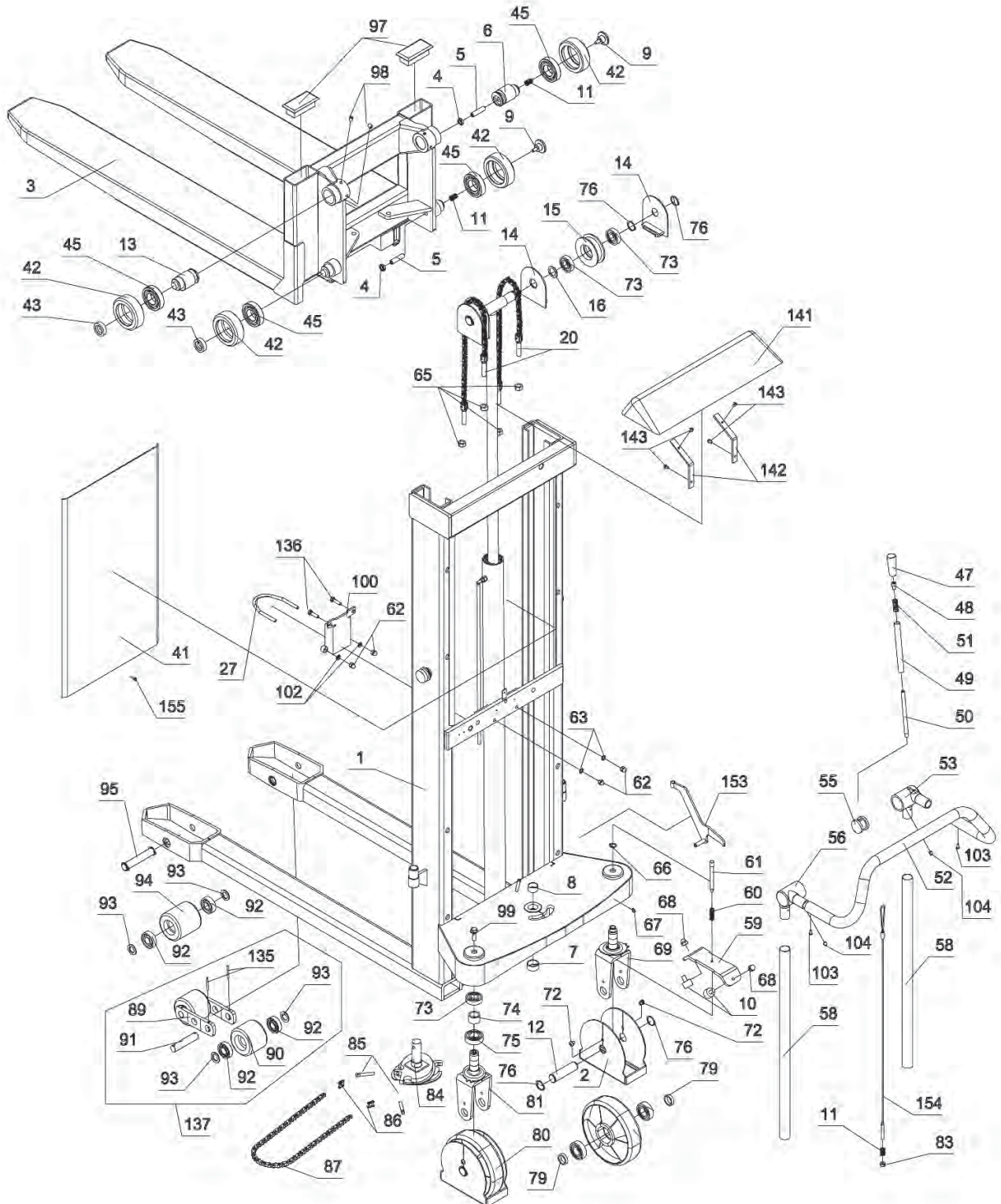

Key#.	Part Description	Qty.	Key#.	Part Description	Qty.
1	Chassis LL 560x1150 B	1	68	Top nut	2
2	Foot protector	2	69	Wheel fork brake wide	1
3	Fork Bracket 560x1150	1	72	Screw	4
4	Counter nut	2	73	Ball bearing	6
5	Pointed screw	2	74	Spacer pipe	2
6	Eccentric roller for spring	1	75	Ball bearing	2
7	Bushing	1	76	Locking ring	
8	Bushing	1	8		
9	Tap for fork bracket	2	79	Spacer pipe	4
10	Rubber for handle	2	80	Steering wheel polyurethane with bearing	2
11	Compression spring	2			
12	Wheel axle	2	81	Revolvable wheel fork	1
13	Eccentric roller	1	83	Lock nut	1
14	Cover for chain roller	4	84	Steering arm tap, wide	1
15	Chain roller	2	85	Chain adjuster	4
16	Washer	2	86	Chain connector	4
20	Lifting chain cpl. 1200	2	87	Steer. wheel chain	2
27	Clamp	1	92	Ball bearing	4
41	Cover	1	93	Spacer pipe	6
42	Mast roll	4	94	Fork wheel polyuretan	2
43	Nylon roll	2	95	Wheel axle	2
45	Ball bearing	4	97	Cover	2
47	Handle	1	98	Pointed screw	4
48	Screw	1	99	Screw	1
49	Brake pin	1	100	Adjust. fittings LF/ELF 1400	1
50	Brake handle	1			
51	Compression spring	1	102	Washer	4
52	Pull grip	1	103	Screw	2
53	Washer right	1	104	Pointed screw	2
55	Washer for handle brake	1	136	Screw	2
56	Washer left	1	141	Plastic top cap for LL1001	1
58	Side pipe	2			
59	Brake strap	1	142	Holder for top cap	2
60	Compression spring	1	143	Screw	4
61	Dowel brake	1	153	Brake arm	1
62	Top nut	4	154	Brake wire	1
63	Spring washer	2	155	Screw	1
65	Lock nut	4	156	Washer	2
66	Locking ring	1			
67	Locking ring	1			

# LL 1001 MS Chassis

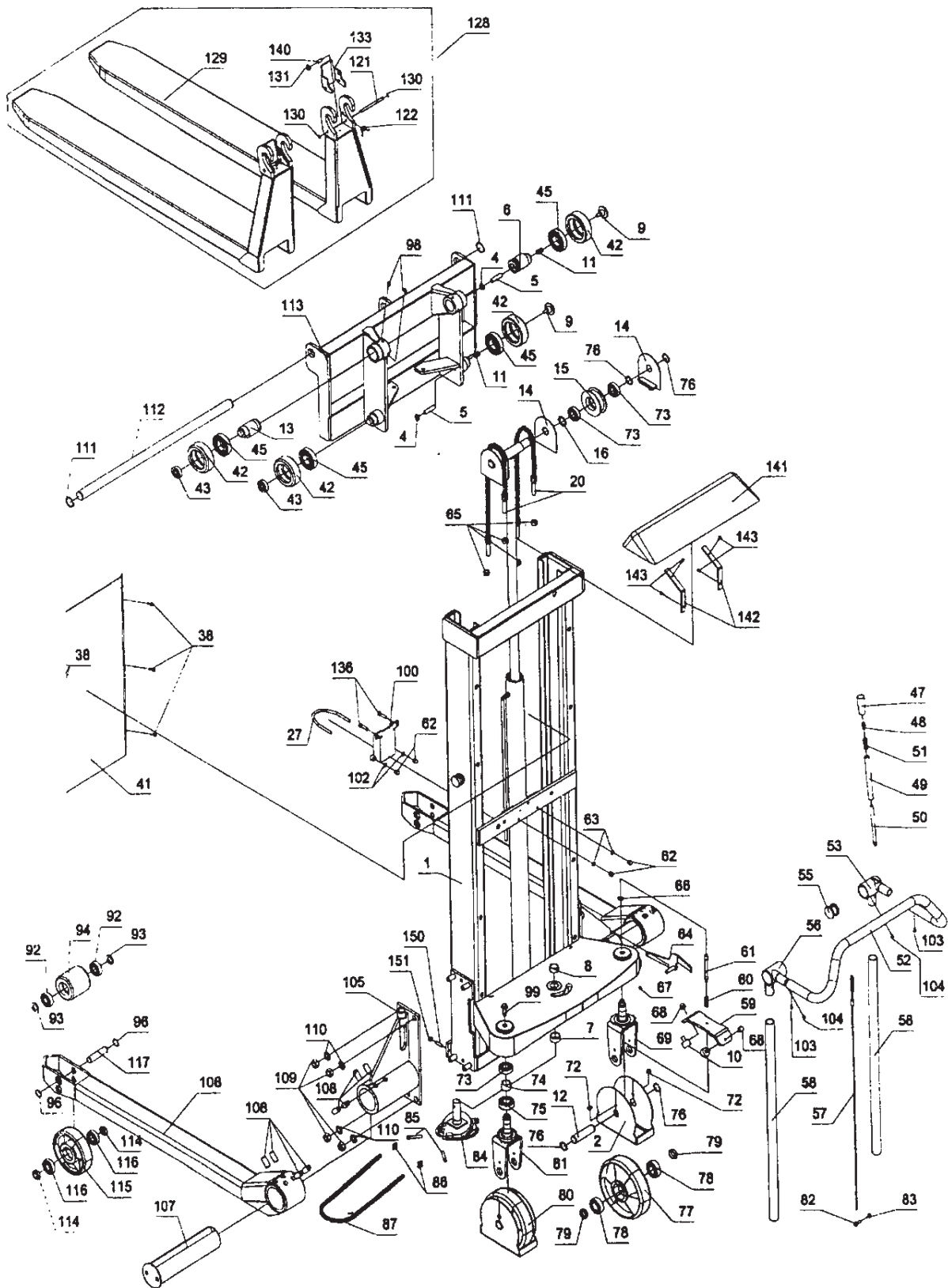

Key#.	Part Description	Qty.	Key#.	Part Description	Qty.
1	Chassis LL 680x600 S	1	60	Compression spring	1
	Chassis LL 680x600 S	1	61	Dowel brake	1
	Chassis LL 680x1150 S	1	62	Top nut	4
	Chassis LL 680x1520 S	1	63	Spring washer	4
	Chassis LL 680x600 B	1	64	Brake arm narrow	1
	Chassis LL 680x800 B	1	65	Lock nut	4
	Chassis LL 680x1150 B	1	66	Locking ring	2
	Chassis LL 680x1520 B	1	67	Locking ring	1
2	Foot protector	2	68	Top nut	2
3	Counter nut	2	69	Wheel fork brake wide	1
4	Pointed screw	2	72	Screw	4
5	Eccentric roller for spring	1	73	Ball bearing	6
6	Bushing	1	74	Spacer pipe	2
7	Bushing	1	75	Ball bearing	2
8	Tap for fork bracket	2	76	Locking ring	9
9	Rubber for handle	2	77	Steering wheel, nylon	2
10	Compression spring	2		Steering wheel, vulkollan	2
11	Wheel axle	2		Steering wheel, vulkollan	2
12	Eccentric roller	1		Steering wheel, steel	2
13	Cover for chain roller	4		Steering wheel, nylon white	2
14	Chain roller	2		Steering wheel, poly	2
15	Washer	2	78	Ball bearing	2
20	Lifting chain cpl. 1200	2	79	Spacer pipe	4
27	Clamp	1	80	Steering wheel, nylon w/bearing	2
38	Screw	10		Steering wheel, vulkollan w/bearing	2
41	Cover 1200/2050	1		Steering wheel, poly w/bearing	2
42	Mast roll	6	81	Revolvable wheel fork	1
43	Nylon roll	4		Wheel fork left narrow	1
45	Ball bearing	6	82	Wire bolt	1
47	Handle	1	83	Lock nut	3
48	Screw	1	84	Steering arm tap, narrow	1
49	Brake pin	1	85	Chain adjuster	4
50	Brake handle	1	86	Chain connector	4
51	Compression spring	1	87	Steering wheel chain, short	2
52	Pull grip	1	92	Ball bearing	2
53	Washer right	1	93	Spacer pipe	6
55	Washer for handle brake	1	94	Fork wheel, nylon	1
56	Washer left	1		Fork wheel, nylon white	1
57	Brake wire	1		Fork wheel, vulkollan	1
58	Side pipe	2		Fork wheel, poly	1
59	Brake strap	1		Fork wheel, steel w/ bearings	1

Key#.	Part Description	Qty.	Key#.	Part Description	Qty.
96	Lock ring	6	114	Spacer pipe	2
98	Pointed screw	4	115	Steering wheel, nylon w/bearing	1
99	Screw	1		Steering wheel, vulkollan w/bearing	1
100	Adjust. fittings, LF/ELF 1400	1		Steering wheel, poly w/bearing	1
102	Washer	4	116	Ball bearing	2
103	Screw	2	117	Wheel axle	2
104	Pointed screw	2	121	Axle for lock fitting	2
105	Bracket straddle legs, short	2	122	Torsion spring	2
	Bracket straddle legs, long	2	128	Set of wrap-over forks 1150	1
106	Straddle legs cpl., short	2		Set of bar forks 1150	1
	Straddle legs cpl., medium	2		Set of chisel forks 1150	1
	Straddle legs cpl., long	2		Set of drum forks 1150	1
107	Middle piece straddle	2	129	Adjustable wrap-over fork 1150	1
	Middle piece straddle	2		Adjustable bar fork 1150	1
	Middle piece straddle	2		Adjustable chisel fork 1150	1
	Middle piece straddle	2		Adjustable drum fork 1150	1
108	Pointed screw	16	130	Locking ring	4
109	Lock nut	8	131	Counter nut	2
110	Washer	8	133	Hook lock	1
111	Locking ring	2	136	Screw	2
112	Shear axle	1	140	Ball bolt	2
113	Fork bracket	1	141	Plastic top cap for LL1001	1
	Fork bracket	1	142	Holder for top cap LL1001	2
	Fork bracket	1	143	Screw	4
	Drum attachment	1	150	Pointed screw	2
	Drum attachment	1	151	Nut	2

# PML-30-ME Electric Hydraulic Pump

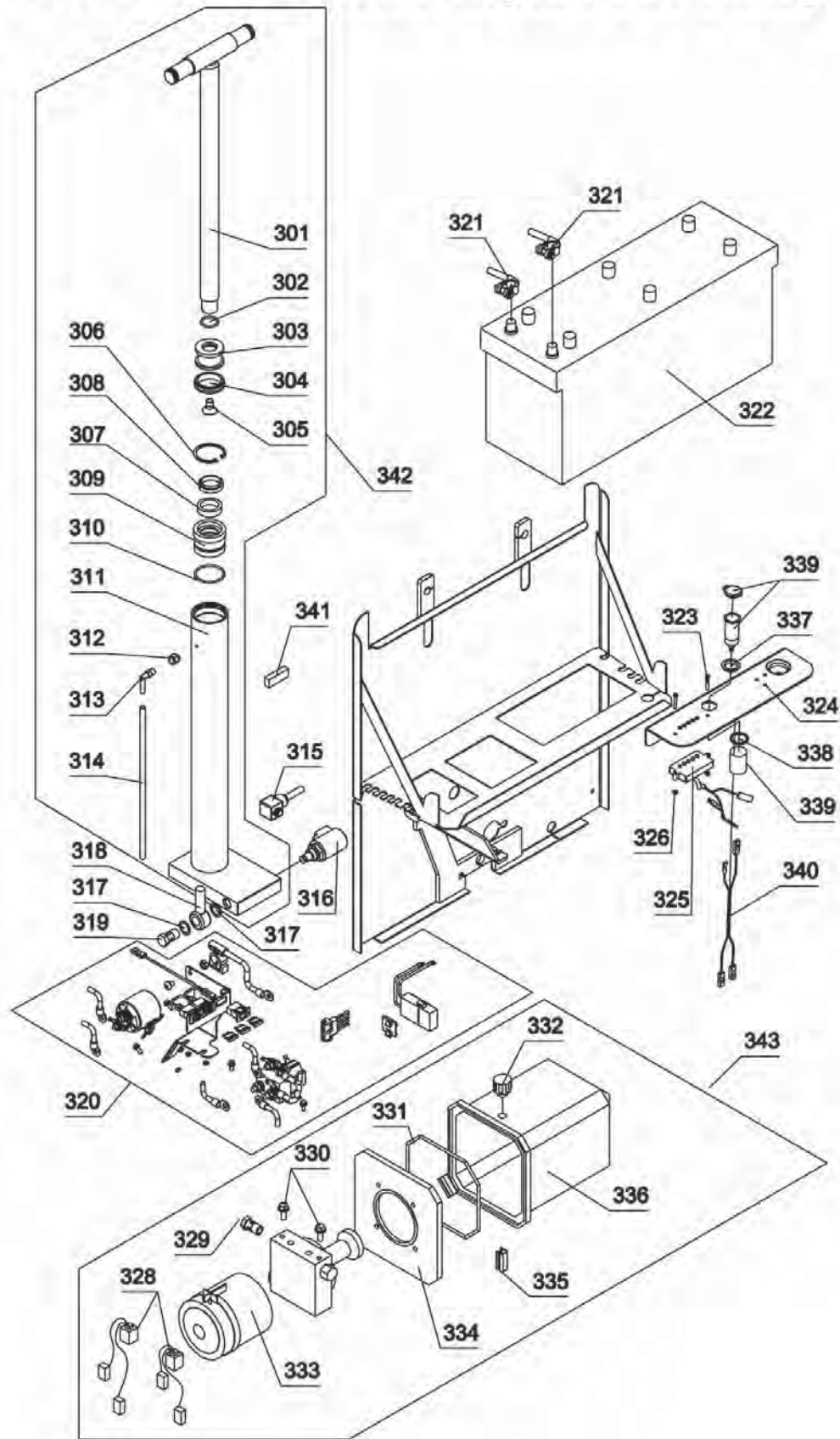

Key#.	Parts Description	Qty.	Key#.	Part Description	Qty.
301	Piston rod 1170/1200	1	324	Instrument board	1
302	O-ring	1	325	Battery indicator	1
303	Piston	1	326	Nut	2
304	Sleeve	1	328	Set of Brushes	1
305	Screw	1		Hpi-Motor 1.1 Kw	
306	Locking ring	1	329	Banjo bolt	1
307	Sleeve	1	330	Screw	2
308	Scraper ring	1	331	O-ring	1
309	Top section	1	332	Filler cab	1
310	O-ring	1	333	Motor 12 V	1
311	Cylinder housing 1170/1200	1	334	Flange f. tank	1
312	Flush bushing	1	335	Clips for Oil Tank ELF/LL	12
313	Angular nipple	1	336	Oil tank	1
314	Overflow hose 1170/1200	1	337	Isolator for universal plug	1
315	Set of wires	1	338	Washer for universal plug	1
316	Solenoid valve	1	339	Universal plug	1
317	Copper washer	2	340	Cable universal plug	1
318	Hy-hose	1	341	Clamp Plate	1
319	Flow valvet	2	342	Cylinder cpl. LL	1
320	See relays and fuses		343	Hy-pump cpl.	1
321	Set of wires cpl.	2		Gasket set for cylinder	
322	Battery	1		All parts marked with* included	
323	Screw	2		Gasket set f. hy-pump (pos. 343)	

# PML-30-ME Charger

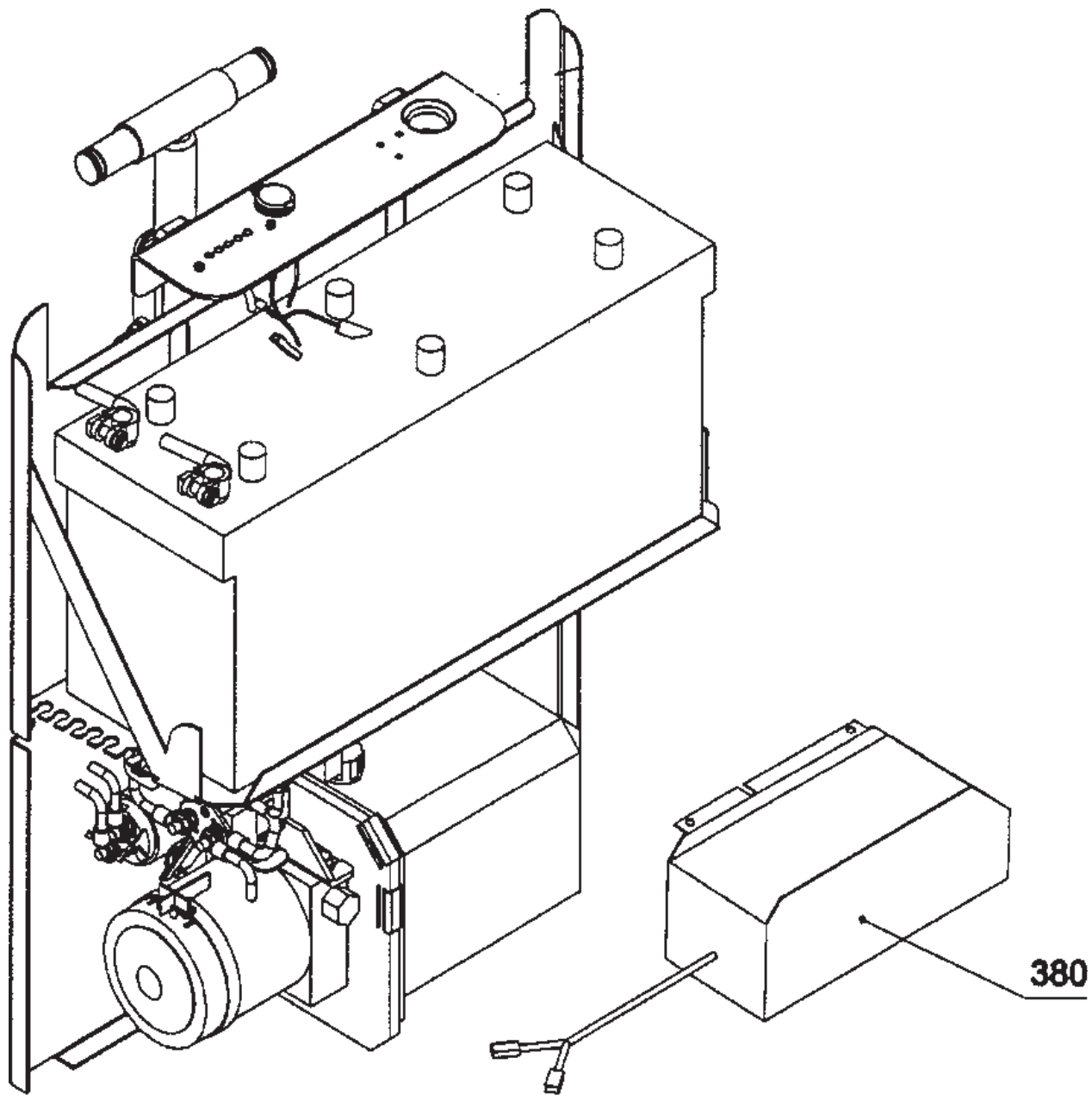

Key#	Parts Description	Qty.
380	Charger 12V, with cable	1

**PML-30-ME**

**Relay and Fuses**

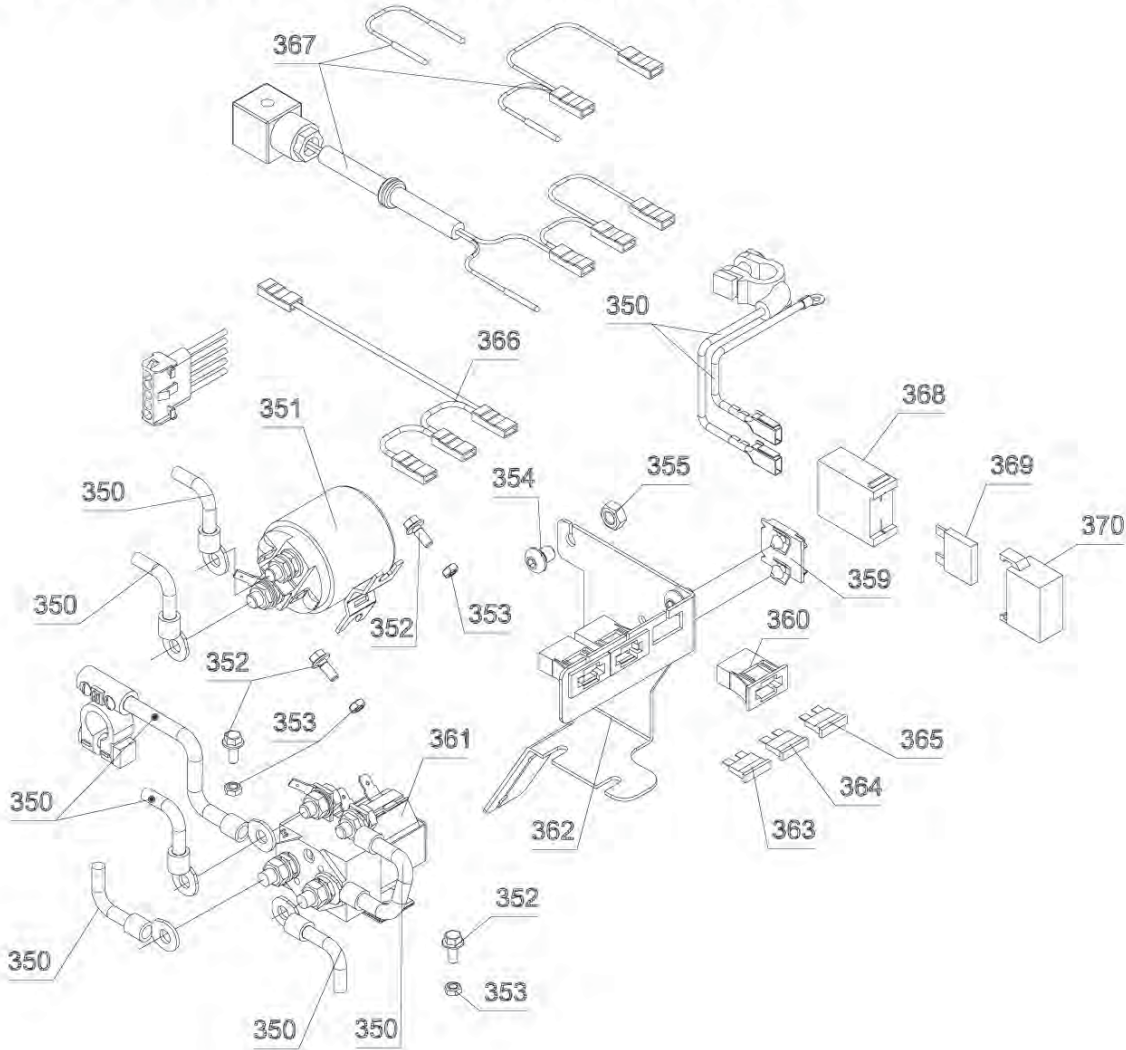

Key#	Parts Description	Qty.
350	Set of cables, 80 Ampfuse	6
351	Starter switch	1
352	Screw	4
353	Nut Mutter	4
354	Screw	2
355	Nut	2
359	Mounting plate - fuse	1
360	Fuseholder	3
361	Relay for closing/opening	1
362	Relay plate	1
363	Fuse 5 Amp	1
364	Fuse 15 Amp	1
365	Fuse 30 Amp	1
366	Set of cables, 3 fuses	1
367	Set of cables, relay/Hirsmann	1
368	30 Amp Fuse holder	
369	Amp Maxi Fuse 80 Amp	
370	Plastic fittings, fuse holder	

# PML-30-ME      Steering gear

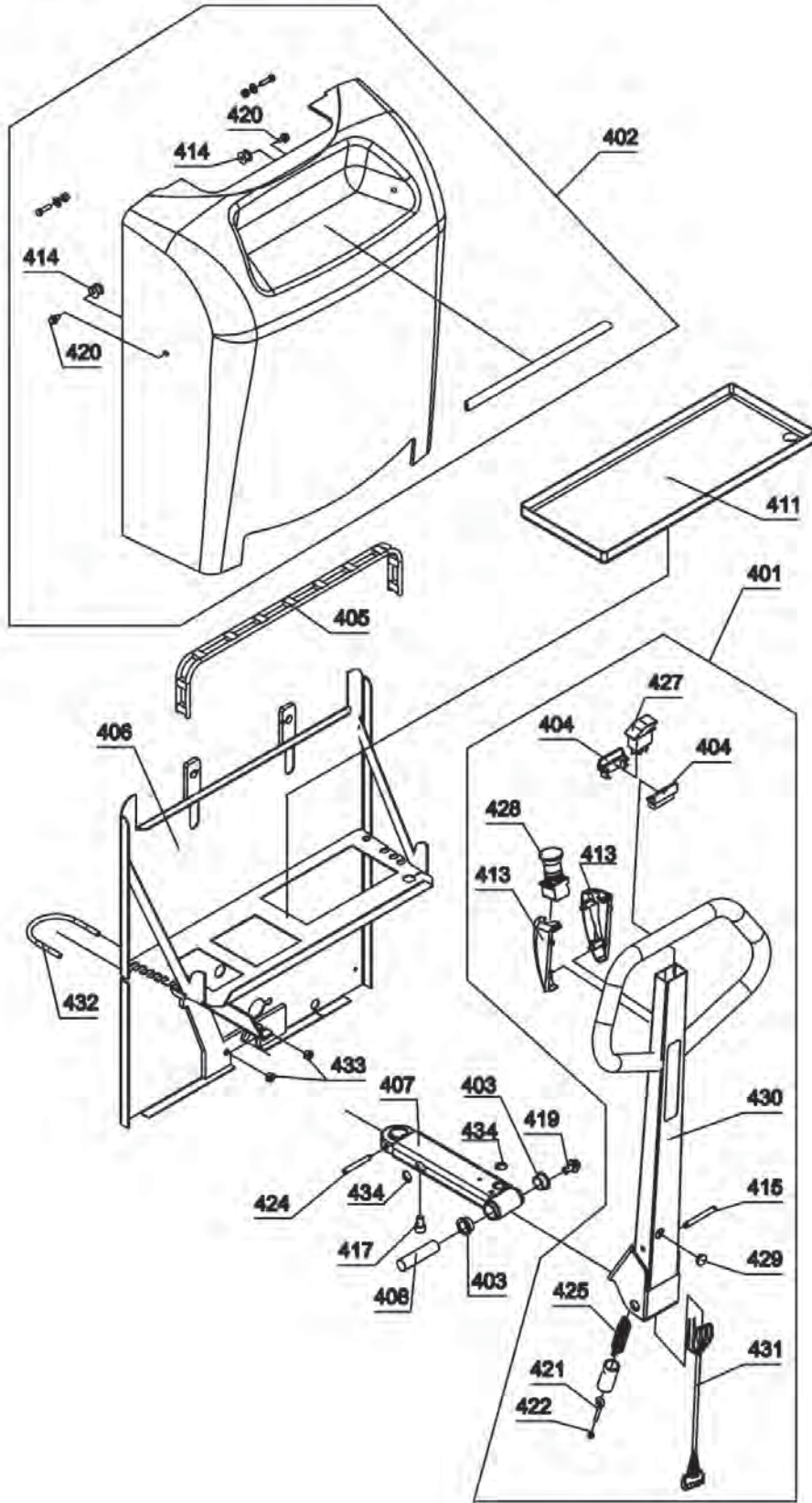

Key#	Part Description	Qty.
401	Handle	1
402	Cover cpl.	1
403	Bushing	2
404	Contact carrier	2
405	Rubber strap for battery	1
406	Pump chassis	1
407	Control lever	1
408	Handle axle ELF	1
409	Cover	1
410	Pipe for battery cover	1
411	Case for battery	1
413	Holder emergency stop	1
414	Holder battery cover	2
415	Transverse pin f. spring	1
417	Screw	1
418	Screw	2
419	Screw	1
420	Screw	2
421	Eye bolt	1
422	Lock nut	1
423	Washer	2
424	Tubular pin	1
425	Spring	1
426	Cable lead-in	2
427	Tilting switch	1
428	Emergency stop switch	1
429	Rubber plug	1
430	Handle ELF	1
431	Handle cable ELF/LLE	1
432	Clamp	1
433	Lock nut	2
434	Cable lead-in	2

### Wiring diagram Main current

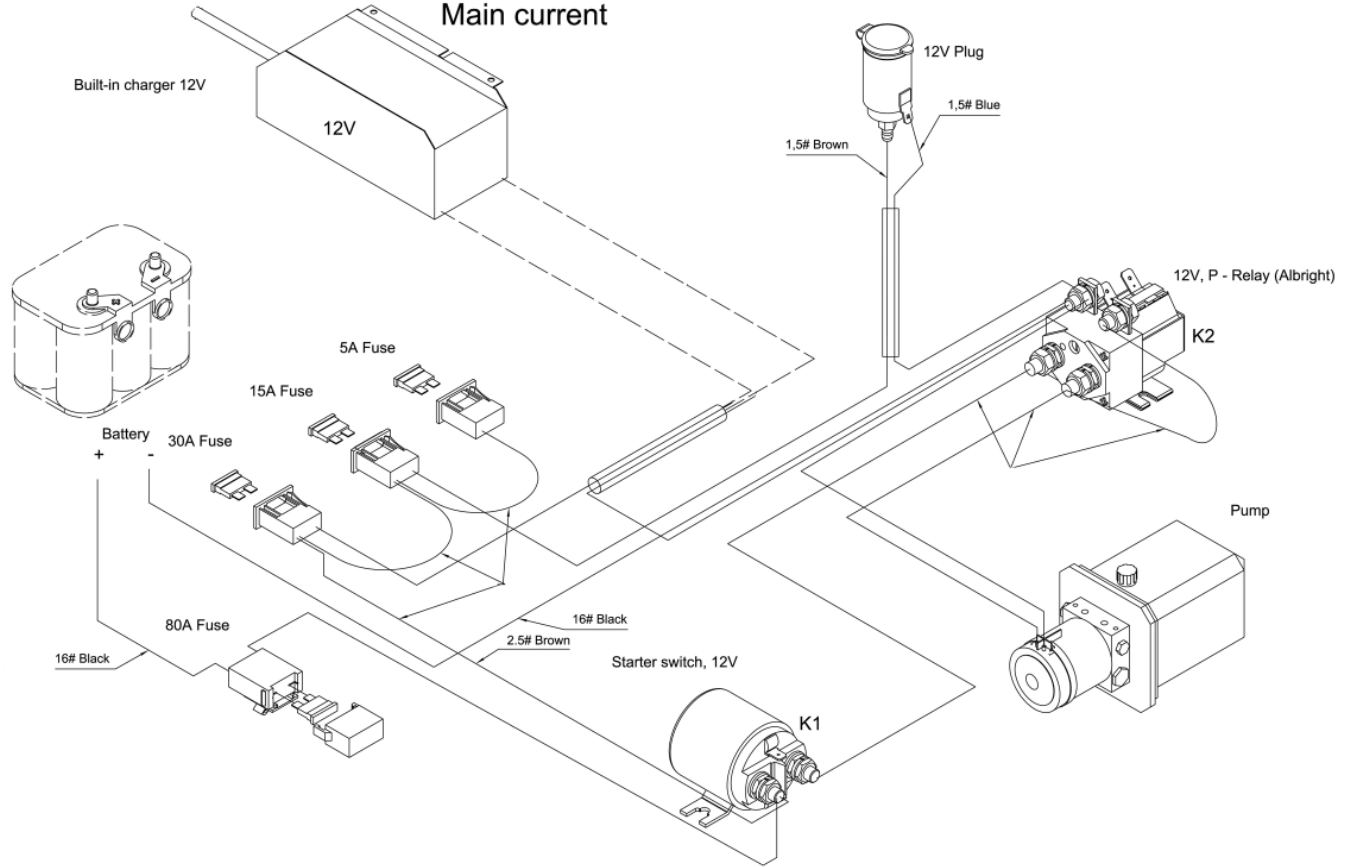

Electric wiring diagram: Main current

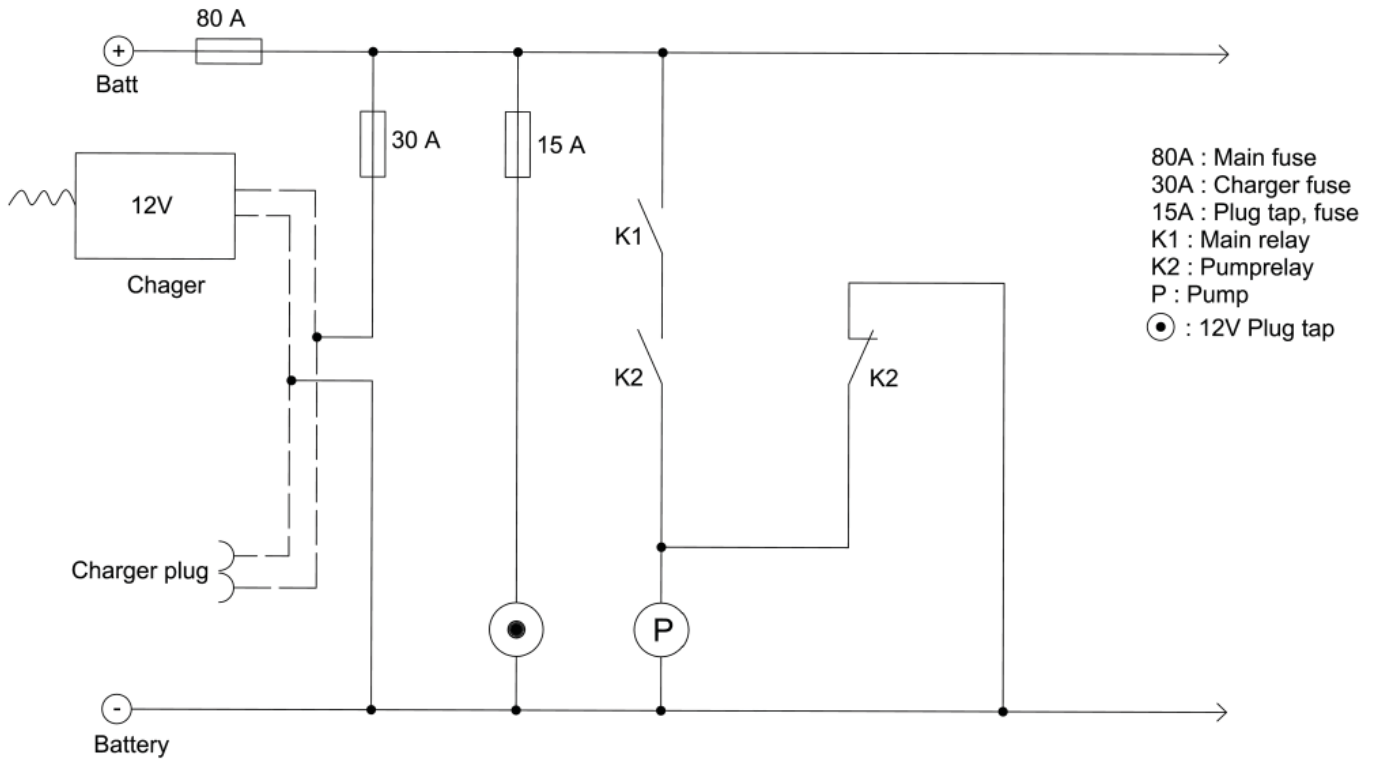

### Electric wiring diagram: Control Current

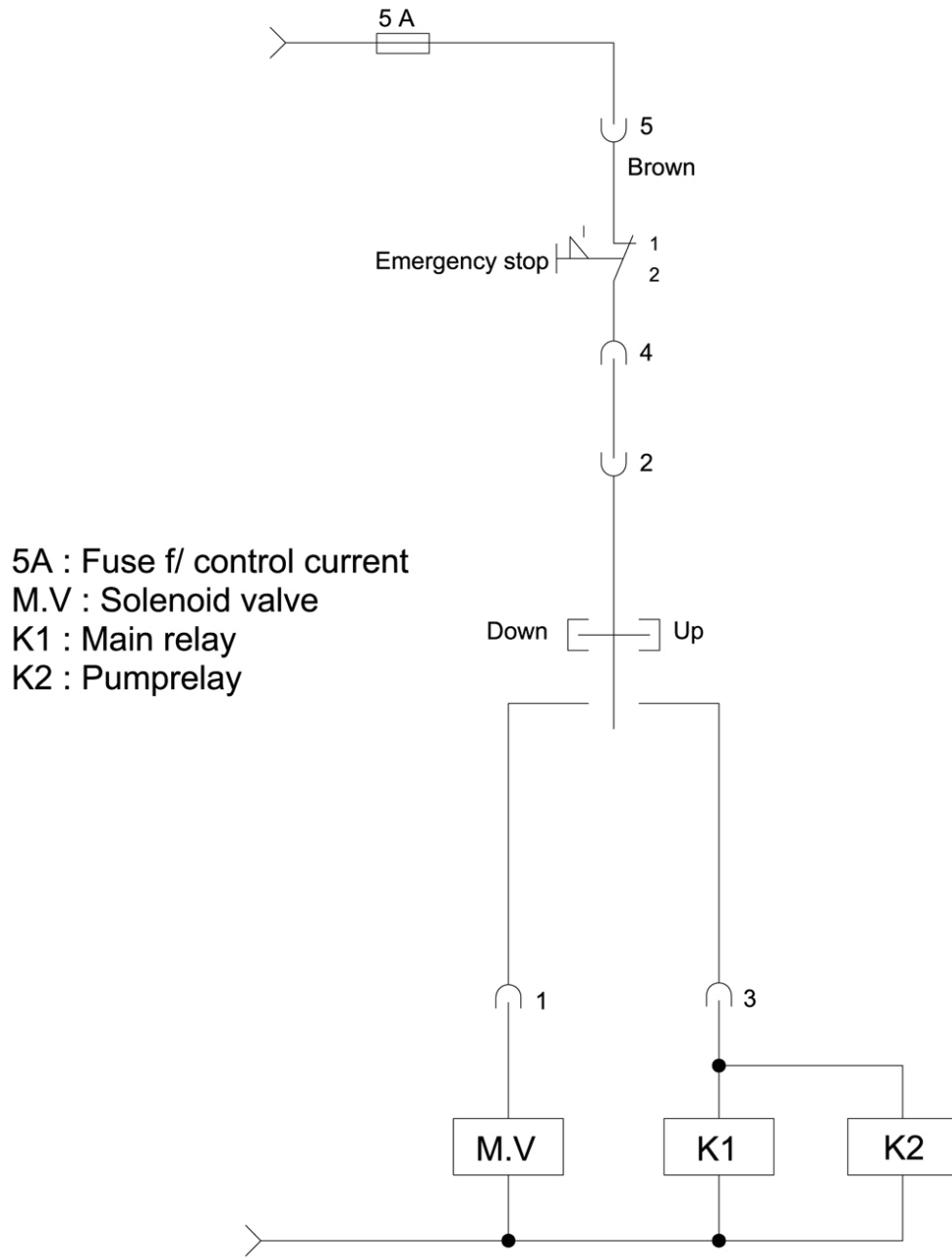

## SECTION TWO



# OPERATOR INSTRUCTIONS

for the

# PML Transpositioner

## OPERATING SAFETY RULES AND PRACTICES

### Operator Responsibility

Safe operation is the responsibility of the operator.

Operators shall develop safe working habits and also be aware of hazardous conditions in order to protect themselves, other personnel, the mail, mail handling equipment and the facilities.

Operators shall be familiar with manufacturer's operating instructions and warnings on the Transpositioner. Operators must be familiar with the operation and function of all controls before operating the Transpositioner.

Before operating the Transpositioner operators should read and understand the Owner's Manual. They should also abide by all precautions, rules and safety requirements including those of the USPS.

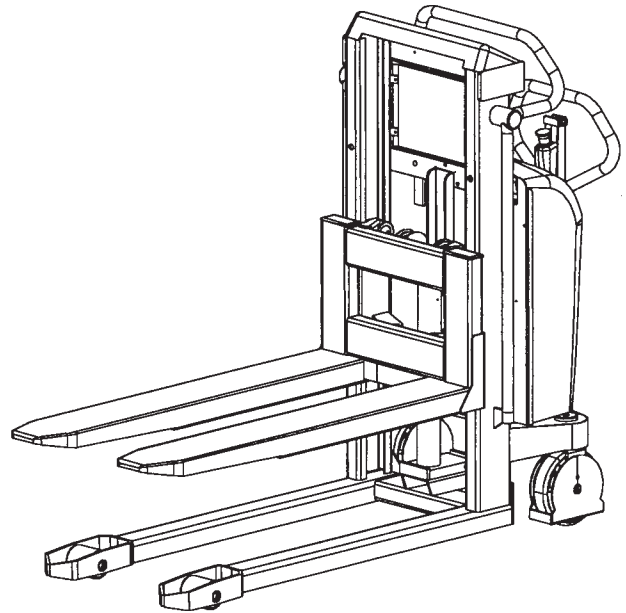

# OPERATOR INSTRUCTIONS

## Southworth PML TRANSPOSITIONER

### Operating the PML Transpositioner:

1. Stand behind the black handle bars of the machine, this is the correct position for operating the PML Transpositioner. (Do not operate from any place other than the operator's position.)
2. Check the battery indicator to be sure there is at least 25% capacity remaining. (If it is less, re-charging the battery is required.)

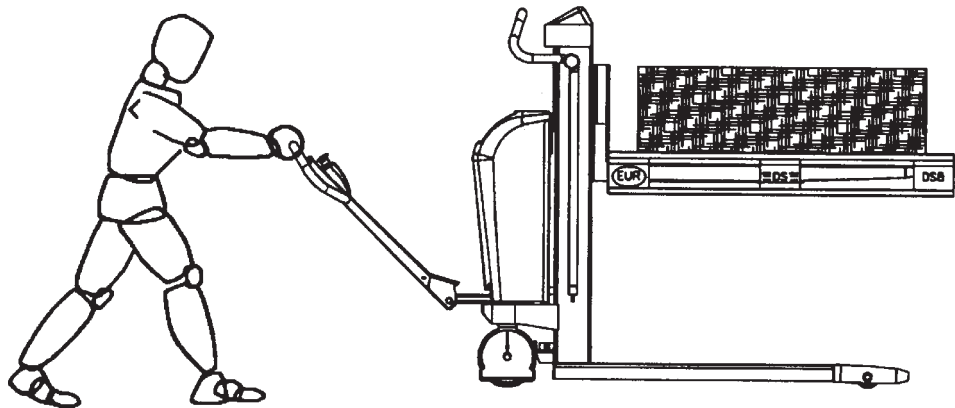

For proper operation, stand behind the handle. Push/pull - raise/lower.

3. If the Emergency Stop button is depressed, release it (twist counter-clockwise)
4. Release the wheel lock.
5. Push or pull the PML Transpositioner into position using the handle to steer (keep feet clear).
6. Always push or pull using the black handle bars provided. Never put any part of the body into the mast structure, lifting mechanism or carriage.
7. When attempting to pick up containers, align forks to the correct width. Approach the container as squarely as possible and go slowly to avoid damaging the container or the PML Transpositioner.
8. Push the Transpositioner as far into the container as possible (the container should be against the mast of the Transpositioner).
9. To raise or lower the forks, push the designated button on the handle. Depress the left button to go down or lower the forks.

Depress the right button to go up or raise the forks.

10. Raise the container just enough to provide floor clearance for transporting. (Never move the PML Transpositioner loaded or empty, with the mast raised any more than a few inches, which is adequate floor clearance.)
11. Instruct personnel to stand clear. Do not maneuver the Transpositioner up to anyone standing in front of an object.
12. Exercise particular care at cross-aisles, doorways, and other locations where pedestrians may step into the path of travel.
13. Maintain a safe distance from pedestrians and keep the Transpositioner under control at all times.
14. When the Transpositioner is located into position and stopped, engage the wheel lock.

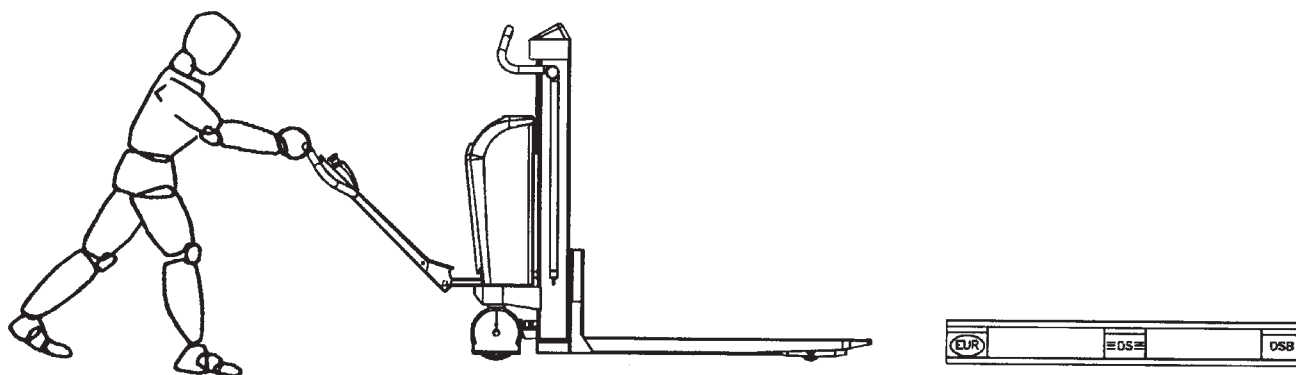

### Loading the Transpositioner

Handle only stable and safely arranged loads, containers, hampers or baskets that are within the capacity of the PML Transpositioner. The capacity is labeled on your machine. If the labels are no longer legible, please call our Service Department for replacements. If you are unsure of the capacity – refer to your owner's manual.

Make sure you always completely engage the load. The fork length(s) of the PML Transpositioner should be at least two-thirds of the load length.

### Operator Care of the Transpositioner

At the beginning of each shift or before operating the Transpositioner check its condition, giving special attention to the following:

- a. Wheels and casters are not damaged;
- b. Guards and precautionary labeling are in place and legible;
- c. Battery indicator reading is 25% or more.

If the Transpositioner is found to be in need of repair or is in any way unsafe, the matter shall be reported immediately to the designated authority and the PML Transpositioner shall not be operated until it has been restored to safe operating condition.

If you have questions please contact:  
Southworth Technical Service Department  
at 1-800-743-1000 or Service@SouthworthProducts.com

## GENERAL SAFETY PRACTICES

The Transpositioner can cause injury if improperly used or maintained. This instruction manual contains broad safety recommendations applicable to typical USPS operations where the Transpositioner has been provided. Only operators trained to adhere strictly to the operating instructions should be permitted to operate the Transpositioner.

### Nameplates, Markings and Capacity

The operator shall see that all nameplates, precautionary, advisory and instructional markings, including capacity ratings, are in place and legible.

### Wheel Lock

The wheel lock is intended only to hold the Transpositioner in a set position on a level surface. It is not intended to be a dynamic brake to slow down or stop a moving Transpositioner.

## Stability

The Transpositioner complies with the stability requirements of the ANSI B56.10 and is very stable when properly operated. Handling containers or loads that exceed the rated capacity, improper operation, faulty maintenance, or poor housekeeping may contribute to a condition of instability.

Some circumstances that may affect stability are surface and floor conditions, speed, load position and the judgment exercised by the operator. *The Transpositioner should only be used within the maximum capacity rating as specified on the nameplate.*

## Guards

Guards are intended to offer protection to the operator from moving parts, but cannot protect against every possible condition. Therefore, they shouldn't be considered a substitute for good judgment and care in use, loading, unloading and handling the Transpositioner.

## Floors and Floor Conditions

Areas of use for the Transpositioner should be smooth, level, and free of wide gaps or cracks that may damage or catch casters or wheels. Maintain floors to keep them free of debris and any liquids that hinder safe operation.

Ramps and inclines shall be avoided in the areas of use.

## Elevating Personnel

The Transpositioner is not intended to be used for elevating personnel at any time, under any conditions. Personnel should never sit, stand or ride on any part of the Transpositioner.

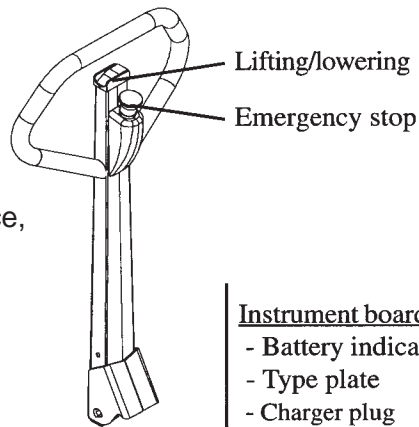

### Instrument board:

- Battery indicator
- Type plate
- Charger plug (internal or external charger)
- Plug for extra equipment, 12V, max. 15Amp

Released position

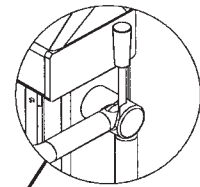

Braked position

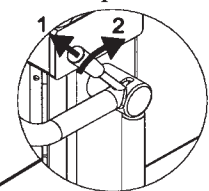

To release:  
**1. Pull**  
**2. Push**

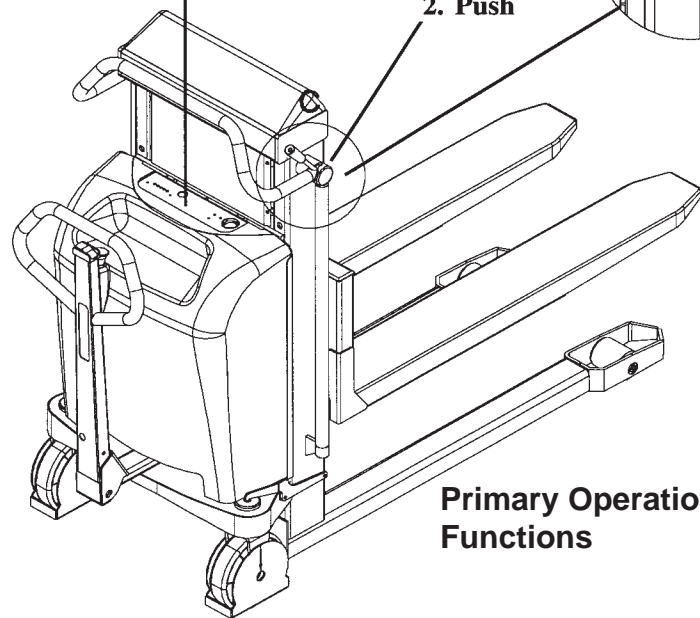

Primary Operation Functions

## 2 YEAR WARRANTY

Southworth Products Corp warrants this product to be free from defects in material or workmanship for a period of **2 years** of single shift usage from date of shipment, providing claim is made in writing within that time period. This warranty shall not cover modified designs for special applications, failure or defective operation caused by misuse, misapplication, negligence or accident, exceeding recommended capacities, failure to perform required maintenance or altering or repairing, unless alteration is authorized by Southworth Products Corp. Except as set forth herein, there are no other warranties, express or implied, including the warranties of merchantability and fitness for a particular purpose, all of which are hereby excluded.

All **batteries have a 90 day parts and labor** warranty, this warranty covers any defects in material and workmanship from the date of shipment.

Southworth Products Corp makes no warranty or representation with respect to the compliance of any product with state or local safety or product standard codes, and any failure to comply with such codes shall not be considered a defect of material or workmanship under this warranty. Southworth Products Corp shall not be liable for any direct or consequential damages arising out of such noncompliance.

Southworth Products Corp's obligation under this warranty is limited to the replacement or repair of defective components at its factory or another location at Southworth Products Corp's discretion. This is buyer's sole remedy. Except as stated herein, Southworth Products Corp will not be liable for any loss, injury or damage to persons or property, nor for direct, indirect, or consequential damage of any kind, resulting from failure or defective operation of said product.

This warranty may be altered only in writing by Southworth Products Corp, Portland, Maine.

**SOUTHWORTH**  
making work faster, safer, and easier

**SOUTHWORTH PRODUCTS CORP**  
P.O. Box 1380, Portland, ME 04104-1380  
Telephone: (800) 743-1000 • (207) 878-0700  
Fax: (207) 797-4734  
[www.SouthworthProducts.com](http://www.SouthworthProducts.com)

# **SOUTHWORTH**

**We'll Show You How**

Southworth is the world class supplier of products designed to improve productivity and enhance safety. Our staff has over 400 years of engineering experience. If one of our standard products does not meet your needs, our engineers can custom design equipment specifically suited to your material handling application.



**Spring PalletPal Load Leveler**



**Lift with Flush Mount Turntable**



**Portable Container Tilters**



**Dock Lifts**



**Roll on Level Loaders**



**Portable Lifts**



**Stretchwrapping**



**Positioning**

**Floor to Mezzanine Lifts**



**Pallet Rotators**



**For more information, contact Southworth Products**  
Telephone (800) 743-1000 Fax (207) 797-4734  
**Email: [salesinfo@SouthworthProducts.com](mailto:salesinfo@SouthworthProducts.com)**