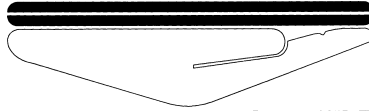


# OWNER'S MANUAL



**SOUTHWORTH**

# LS Series Lift Tables

**L, LS, LSW, LST and LSTW Models**



Model # \_\_\_\_\_

Serial # \_\_\_\_\_

Date placed in Service \_\_\_\_\_

**SOUTHWORTH PRODUCTS CORP**

P.O. Box 1380 • Portland, ME 04104-1380

Telephone: (207) 878-0700 or (800) 743-1000

Fax: (207) 797-4734

[www.SouthworthProducts.com](http://www.SouthworthProducts.com)

Email: [service@SouthworthProducts.com](mailto:service@SouthworthProducts.com)

Please note: This manual was current at the time of printing.  
To obtain the latest, most updated version, please contact  
Southworth's Customer Service Department or go to our website:  
[www.SouthworthProducts.com](http://www.SouthworthProducts.com), under E-Parts & Service  
you will find a complete list of current  
owner's manuals to print.

# Southworth LS Series Lift Table Owner's Manual

## CONTENTS

INTRODUCTION .....	1
Safe Servicing of the Lift .....	2
SAFETY .....	3
INSTALLATION INSTRUCTIONS .....	3
Preparation .....	3
Positioning the Lift .....	4
Hydraulic Connections .....	4
Electrical Connections .....	5
Testing .....	5
Completing Installation .....	5
Smartlift Programming .....	6
Charging a Battery .....	7
OPERATING INSTRUCTIONS .....	9
Operating Procedure .....	9
MAINTENANCE .....	11
Hazards .....	11
Routine Periodic Maintenance .....	12
High Cycle Package .....	12
Flushmount Turntable .....	13
Units with Air Motors .....	13
TROUBLESHOOTING .....	14
Troubleshooting Check List .....	14
Repacking Cylinders .....	15
Replacing Leg Rollers .....	17
Ordering Replacement Parts .....	18
Electrical Connections for Single-Phase AC .....	21
Electrical Connections for Three-Phase AC .....	23

## List of Figures

Figure 1	Safe Servicing of Lift .....	2
Figure 2	Mount the Lift Securely .....	3
Figure 3	Using Lifting Eyes .....	4
Figure 4	Center the Load .....	6
Figure 5	Secure the Load .....	6
Figure 6	Pinch Points .....	9
Figure 7	Labels and Precautionary Markings, Comfort Edge Tabletops .....	9
Figure 8	Labels and Precautionary Markings, Straight Skirt and Bevel Toe Guard Platforms .....	10
Figure 9	H-Style Cylinder .....	16
Figure 10	Parts Identification, Side View .....	17
Figure 11	Parts Identification, View of Motor and Pump .....	18
Figure 12	Parts Identification, LS-2 Models .....	19
Figure 13	Parts Identification, LS-4 Models .....	19
Figure 14	Parts Identification, LS-6 Models .....	20
Figure 15	Hydraulic Pump and Down Valve .....	20
Figure 16	Electrical Connections, Lifts Wired for Single-Phase AC .....	21
Figure 17	Wiring Diagram, Lifts Wired for Single-Phase AC without limitswitch .....	21
Figure 18	Wiring Diagram, Lifts Wired for Single-Phase AC with limitswitch .....	22
Figure 19	Electrical Connections, Lifts Wired for Three-Phase AC .....	23
Figure 20	Schematic, Lifts Wired for Three-Phase AC .....	24
Figure 21	Hydraulic Connections .....	24
Figure 22	Hydraulic Diagram - Unit with Electric Motor .....	25
Figure 23	Hydraulic Diagram - Unit with Air Motor .....	25
Table 1	Electrical Interface, Supplied by Customer .....	26
Table 2	Hydraulic Oil Specifications .....	26



## INTRODUCTION

Southworth's LS series is our basic lift table line, containing over 400,000 combinations of load capacity, vertical travel, table size, power source, and other characteristics. The LS line, and this manual, also include the LST (tandem) lifts, and the LSW (wide-base) styles. LS lift tables can also be supplied with a large assortment of optional accessories and modifications to suit the customer's needs. Some variations use an air motor to power the hydraulic pump. "High cycle" units are designed for especially heavy use.

This manual contains information to acquaint you with the safe and proper installation, use, and upkeep of an LS series lift table. You should ensure that this manual is available to personnel working with and on the lift table and require its use by these personnel.

LS lift tables are designed for lifting and vertical positioning of equipment and materials in a wide variety of industrial settings. The instructions set forth in this manual are not necessarily all-inclusive, as Southworth cannot anticipate all conceivable or unique situations.

**Please read all of this manual carefully, and be familiar with its contents before you install, use, or service the LS Lift Table. If you have any questions about any of the instructions in this manual, please contact your dealer or Southworth Products Corp.**

Southworth's product warranty is shown on the back cover of this manual. This instruction manual is **not intended to be or to create any other warranty, express or implied, including any implied warranty of merchantability or fitness for a particular purpose, all of which are hereby expressly excluded.**

As set forth more specifically in the product warranty, Southworth's obligation under that warranty is **limited** to the repair or replacement of defective components, which shall be the buyer's **sole remedy**, and Southworth shall not be liable for any loss, injury, or damage to persons or property, nor for any direct, indirect, or consequential damage of any kind resulting from the LS lift table.

## SAFE SERVICING OF THE LIFT

### **WARNING !**

Only authorized personnel should perform inspection or maintenance and service procedures. Unauthorized personnel attempting these procedures do so at the risk of severe injury or death.

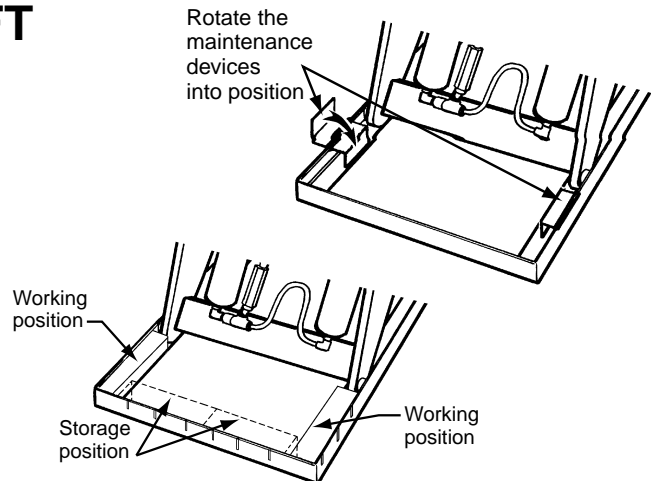
### **DANGER !**

Failure to properly adhere to lift blocking procedures is to risk the sudden and uncontrolled descent of the lift during maintenance or inspection. A falling lift can cause severe injury or death.

This procedure describes the only factory-approved method of working under a lift. Follow these instructions **EVERY** time you plan to reach or crawl beneath the lift to perform service or maintenance – no matter how momentary that might be.

If the factory-provided maintenance device is damaged or missing, stop immediately and consult the factory for assistance. The manufacturer is not liable for your failure to use the approved maintenance device(s) and procedures that have been provided.

1. Any load must be removed from the lift prior to engaging the maintenance device(s). These devices are designed to support an unloaded lift only. Failure to remove the load from the lift prior to blocking could cause the failure of the maintenance device(s) and allow the lift to fall unexpectedly. This can result in personal injury or death, or permanent damage to the maintenance device(s) and/or the lift.
2. Raise the lift to its fully raised position. If you do not, the maintenance device(s) may not be able to be placed properly in its/their designed blocking position.
3. Remove the maintenance device(s) from its/their storage location and place it/them into the engaged position as shown in Figure 1. (Note: further information may be useful here to provide additional instructions as to the location and method of storage and engaged positions).
4. Lower the lift until it makes complete contact with the maintenance device(s). Re-check to ensure that all provided devices are fully and securely engaged. If the device(s) is/are not fully engaged the lift could fall unexpectedly, resulting in permanent damage to the device(s) or the lift.



**Figure 1 – Safe Servicing of Lift**

### **DANGER !**

If for any reason you are unable to lower the lift completely onto the maintenance device(s), stop immediately and consult the factory. Failure to properly use the factory approved maintenance device(s) could result in severe injury or death.

5. (For single-acting hydraulic, and pneumatic lifts) Once the maintenance device(s) is/are properly and securely engaged, continue to press the down button, valve or switch for an additional 5-10 seconds to relieve all pressure in the operating system (add more specifics here as required for pneumatic lifts).

### **WARNING !**

Failure to relieve operating system pressure could result in the sudden and unexpected release of high pressure fluids (or air) during maintenance and/or repair of the lift and result in severe injury or death.

6. Follow OSHA electrical lock-out/tag-out procedures. Disconnect and tag all electrical and/or other power sources to prevent an unplanned or unexpected actuation of the lift.
7. Once inspection or work is complete, reverse the performance of the steps above to raise the lift off the maintenance device(s) and place the device(s) back into its/their designated storage position(s).

### **DANGER !**

**HIGH VOLTAGE ! – Disconnect and/or lock out the electrical supply to the power unit prior to any installation or maintenance being performed.**

## SAFETY

The safety of all persons operating, maintaining, repairing, or in the vicinity of the LS lift table is of paramount concern to Southworth. The lift table is a powerful machine with moving parts, and is **capable of causing personal injury if proper precautions are not taken**.

Therefore, throughout this manual, Southworth has identified certain hazards which may occur in the use of the lift table, and provided appropriate **instructions** or **precautions** which should be taken to avoid these hazards. In some cases, Southworth has also pointed out the **consequences** which may occur if Southworth's instructions or precautions are not followed. Southworth uses the following system of identifying the severity of the hazards associated with its products:

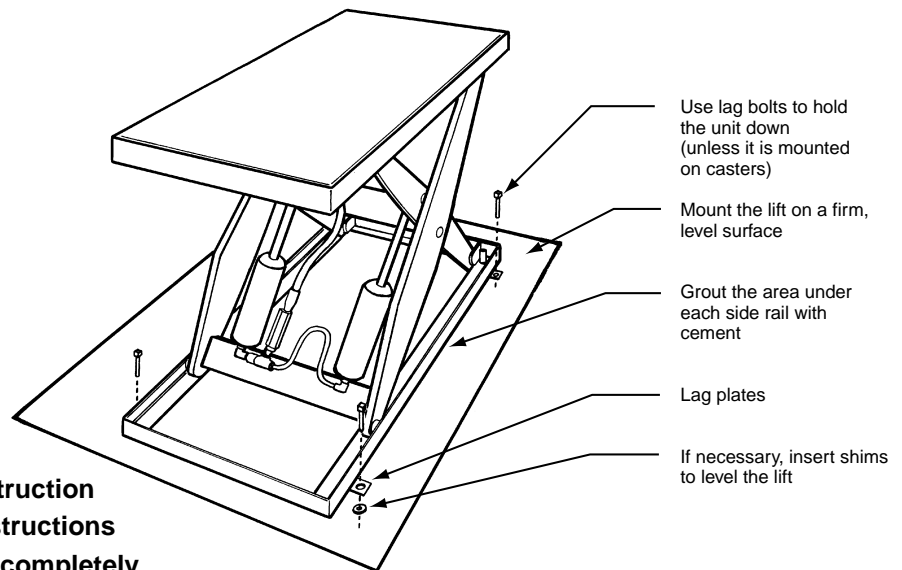
**SIGNAL WORD** is a word or words that designate a degree or level of hazard seriousness. The signal words for product safety signs are "**DANGER, WARNING and CAUTION**". Below is each signal word along with their definitions referenced directly from ANSI Z535.4-1998.

**"DANGER"** Indicates an imminently hazardous situation which, if not avoided, will result in death or serious injury. This signal word is to be limited to the most extreme situations.

**"WARNING"** Indicates a potentially hazardous situation which, if not avoided, could result in death or serious injury.

**"CAUTION"** Indicates a potentially hazardous situation which, if not avoided, may result in minor or moderate injury. It may also be used to alert against unsafe practices.

**Figure 2 -  
Mount the  
Lift Securely**



**Please read and follow this instruction manual, including all safety instructions and precautions, carefully and completely.**

## INSTALLATION INSTRUCTIONS

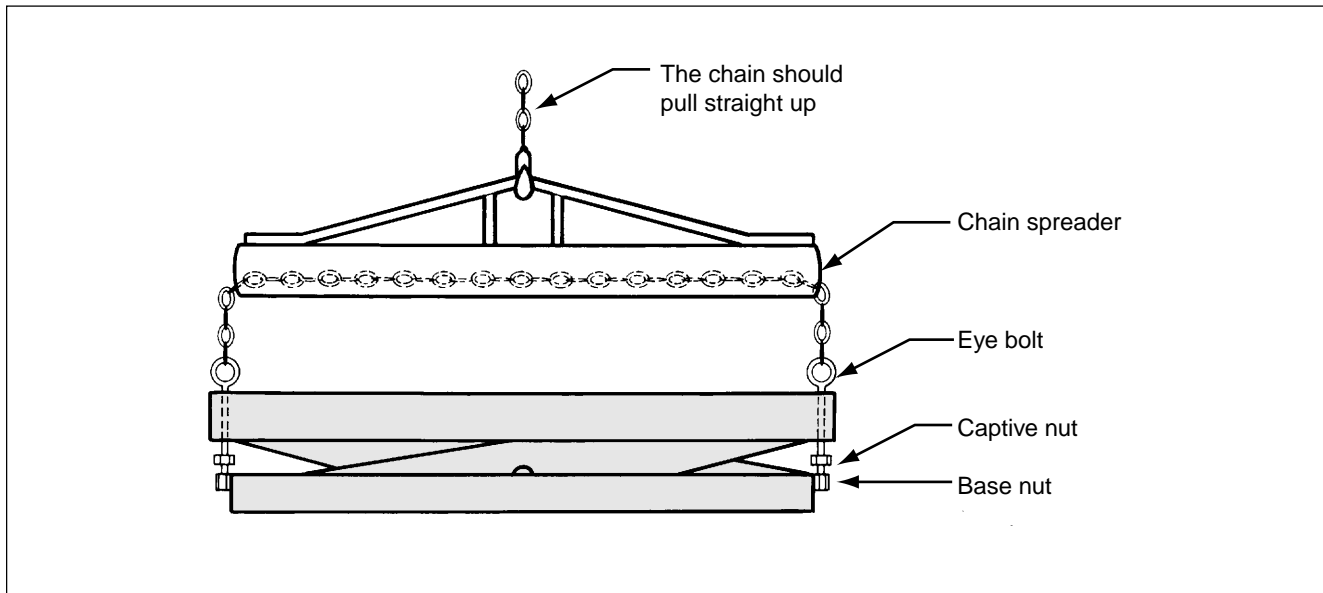
### Preparation

1. Before you start to install the lift, check for local codes and ordinances that may apply. It is your responsibility to obtain any necessary permits.
2. **Read all of these installation instructions carefully. Be sure to read and understand all of the warnings!**
3. If your unit is designed to be installed in a pit, check the pit before you start to install the lift. Measure the length and width of the lift table, then measure the pit, and be sure the pit allows adequate clearance. Does

the pit have 90° angles at each corner? To check, measure across the opposite corners of the pit. The measurement on each diagonal should be the same, within 1/2 inch. The walls of the pit should be vertical. Check with a carpenter's square.

4. If the power unit will be mounted away from the lift ("external power unit"), check the mounting arrangement for the power unit. The power unit should be sheltered from the weather. It should be mounted within 30 feet of the lift to minimize the pressure drop in the hydraulic system. Be sure the hydraulic lines have been installed properly.

## LS Series Lift Tables



**Figure 3 – Using Lifting Eyes**

### **WARNING!**

**Protect the power unit from rain or moisture. If the electrical parts in the power unit get wet, workers may be hurt by electrical shock. The electrical parts may fail if they are wet.**

### **WARNING!**

**The electric motor in the lift can create sparks. Do not install the power unit in an area where flammable gases may be present.**

5. If the power unit is mounted within the lift (“internal power unit”), you will need these tools:

- A crane or lift truck that can lift the unit safely.
- Shims and lag bolts – see the pit plan if the lift will be mounted in a pit.
- A masonry drill and bit to drill the holes for the lag bolts.
- A power supply with the specified voltage, including fuses or circuit breakers as specified in Figures 16 through 20.

If the power unit will be mounted away from the lift (“external power unit”), you will also need:

- A compressed air source for clearing the hydraulic lines.
- Extra hydraulic oil for flushing the underground lines and refilling the tank. See Table 2 for the oil specifications.

### **Positioning the Lift**

6. Remove the shipping material and unskid the lift. On the front of this manual, write down the model

number, serial number, and date the lift is placed in service. You can find the model number and serial number on the name plate as shown in Figure 10. You cannot see the name plate without lifting the table top. Use an overhead crane or fork truck to do this. Lift the hinged end of the table top.

7. Move the lift into position, supporting the base of the lift. Install the lift as shown in Figure 2. Unless the lift is mounted on casters, lag the lift to the floor.

### **CAUTION!**

Do not hang the lift from the table top. This can damage the lift.

### **WARNING!**

**If the lift is mounted on an unstable surface, it may tip over when it is in use. You may be hurt, and the lift and load may be damaged.**

If your lift has lifting eyes, as shown in Figure 3, use these when you move the lift. It is best to use a chain spreader, so the chain sections pull straight up. (You must supply the chain and spreader.) Remove the lifting eyes once you have moved the lift.

### **Hydraulic Connections**

(External Power Units Only – If Internal Power Unit, proceed to step 10.)

8. Install the power unit. Install the hydraulic line between the power unit and the lift as shown on the pit plan.

9. Blow out the hydraulic line with compressed air before connecting it to the power unit. Replace the solid plug on the hydraulic fluid tank with the vented plug supplied, then attach the vent line to the vented plug.

## WARNING!

**Be sure that the hydraulic line will not be pinched by the lift as it raises or lowers. If you allow the line to be pinched, the lift may not work properly. A hose may break, the lift table may drop suddenly, and someone may be hurt.**

## CAUTION!

It is very important to keep the hydraulic oil free of dirt, dust, metal chips, water, and other contamination. Most of the problems with hydraulic systems are caused by contamination in the oil. Be sure to flush all hydraulic lines before connecting remote power units.

## CAUTION!

If you do not install the vented plug in the tank, the pump may be damaged.

## Electrical Connections

**This lift will require a dedicated 20 amp circuit serving no other electrical devices.**

**Do not operate this lift with an extension cord.**

## DANGER!

**The lift may use a power supply of up to 575 Volts AC. This voltage can kill you. Do not work with the electrical parts unless you are a qualified electrician.**

10. Make temporary electrical connections to the lift, as shown in Figure 17 or 18 (for single-phase AC) or Figure 19 (for three-phase AC). This temporary set-up will allow you to raise the lift.

## WARNING!

**The fusing requirements are shown in Table 1. To avoid fire danger, follow these requirements.**

11. On a lift designed for three-phase AC, you must be sure the pump motor is turning in the right direction. The lift table should start to move quickly when you press the “up” or “down” button. If the lift table does not move in 2 or 3 seconds, don’t try to operate the lift! Exchange any two of the three-phase leads. If this does not correct the problem, see the troubleshooting instructions at the end of this manual.

## CAUTION!

If you have a unit designed for three-phase AC and you connect the power so the motor runs backwards, the lift will not operate, and you may damage the pump. Do not operate the lift for more than 2 or 3 seconds if you think the motor might be turning backwards.

12. **Raise the lift and insert the maintenance devices, as shown in Figure 1.**

13. Make the permanent electrical connections as shown in Figure 17 or 18 (for single-phase) or Figure 19 (for three-phase).

14. Check the level of the hydraulic fluid. On most models, when the lift is fully elevated, the oil should be about 3/4 inch above the bottom of the tank. Use a dipstick to check the oil level, and add oil as necessary.

## Testing

15. Clear the area around the lift. Remove any loose wires, lumber, or other materials that might get in the way of the lift as it raises or lowers.

16. Remove the maintenance devices and warn others to stay away from the lift. Operate the lift through its full range of travel. The lift should rise smoothly with a quiet humming sound, and lower smoothly and quietly. Raise and lower the lift a few times to check the clearances around the lift table.

## WARNING!

**As the lift table moves up and down, “pinch points” are created at the places shown in Figure 6. If you are standing too close to the lift when it is moving, your arm or leg may be caught in the moving parts, and you may be hurt. Stay away from the pinch points when the lift is moving.**

## Completing Installation

17. If your lift is mounted in a pit, align the unit with the sides of the pit. Once you are sure the lift is positioned correctly, mark the locations of the lag holes in the base frame, and drill the holes. If necessary, insert metal shims to level the base of the lift. Insert and tighten the lag bolts to secure the lift. Grout under the base rails to prevent vibration and distortion of the base frame, as shown in Figure 2.

18. If the lift is lowering too quickly or too slowly, you can change the “down speed” by adjusting the flow control.

## WARNING!

**When adjusting the flow control, always raise the lift table and insert the maintenance devices, as shown in Figure 1. Do not try to adjust the flow control while pressing the “down” button. If you try this, the lift table may drop suddenly, and you may be hurt.**

It is important that you follow these steps when adjusting the flow control:

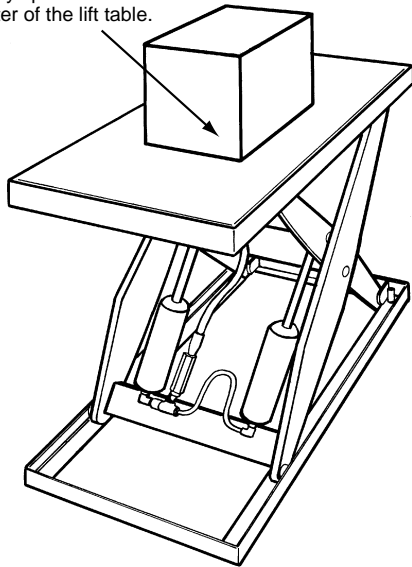
- **Raise the lift table and insert the maintenance devices, as shown in Figure 1.**

## LS Series Lift Tables

- If you want the lift to lower more slowly, turn the control clockwise up to 1/4 turn at a time. If you want the lift to lower more quickly, turn the control counterclockwise up to 1/4 turn. Do not move the control more than 1/4 turn at a time.
- Remove the maintenance devices, and check the descent speed.
- Every time you want to change the adjustment again, raise the table again and insert the maintenance devices as shown in Figure 1.

19. Test the lift with the rated load. If the lift does not rise, and you hear a loud squealing noise, the pressure relief valve is operating. Contact Southworth for instructions.

Always place the load in the center of the lift table.

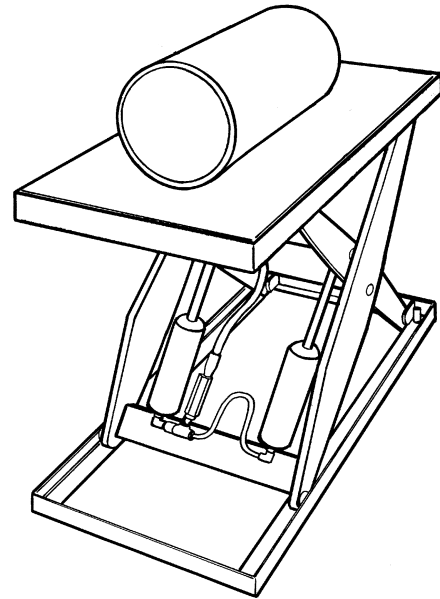


**Figure 4 -  
Center  
the Load**

### WARNING!

**Do not continue to use the lift if this happens – the pump will overheat very quickly, and may be permanently damaged. Do not try to adjust the relief valve. If you change the setting on the relief valve, you may overwork the lift. This can cause the lift to fail suddenly, and you may be hurt.**

20. As a final step, clean up all spilled hydraulic fluid. Spilled hydraulic oil is slippery, and may present a fire hazard.



**Figure 5 -  
Secure  
the Load**

## SMARTLIFT PROGRAMMING

To program SmartLift the following steps must be taken:

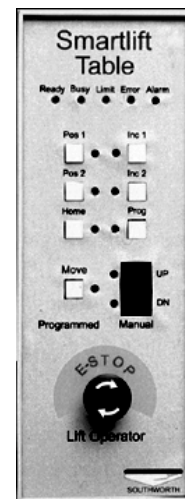
### FOR INCREMENTS

- TOUCH BUTTON <PROG>
- TOUCH BUTTON <INC 1 or 2>
- HOLD UP or DOWN BUTTON FOR LENGTH OF INCREMENT
- TOUCH BUTTON <PROG>

### FOR POSITIONS

- TOUCH BUTTON <HOME>
- TOUCH BUTTON <PROG>
- TOUCH BUTTON <POS 1 or 2>
- HOLD UP BUTTON TO RAISE LIFT TO POSITION
- TOUCH BUTTON <PROG>

Programming increments or positions overrides previous programs. Smartlift retains programmed settings even when unplugged.



### **Preparing to Charge a Battery**

1. Be sure area around the lift and battery is well ventilated while the battery is being charged.
2. The battery terminals, connections and wiring including the plug in the battery box and charger connections should be clean and free of corrosion. When cleaning any of these components wear a face shield or other suitable protective eyewear.
3. For a sealed battery (a battery without cell caps) carefully follow the manufacturer's recharging instructions that are provided with the battery. If you do not have a copy of these instructions or the instructions for the battery charger they are available free of charge by calling Southworth Products Corp at 1-800-743-1000.
4. Read, understand and follow all battery and battery charger manufacturer's specific precautions while working with and/or charging batteries.

### **Locating the Charger**

1. Locate the charger as far away from the battery as the cables permit.
2. Do not operate the charger in a closed area or restrict ventilation in any way.
3. Locate the charger at least 18" above the floor.

## **PRECAUTIONS FOR GROUNDING AND AC POWER CORD CONNECTION**

**Charger should be grounded to reduce risk of electric shock. The charger is equipped with an electric cord having an equipment-grounding conductor and grounding plug. The plug must be plugged into an outlet that is properly installed and grounded in accordance with all local codes and ordinances.**

### **DANGER**

**Never alter the AC cord or plug provided. If it will not fit the outlet, have a proper outlet installed by a qualified electrician. Improper connection can result in a risk of an electric shock.**

## LS Series Lift Tables

### Battery Charger Connection Precautions

**CAUTION: Connect and disconnect the DC output plug (or clips) only when the AC cord is disconnected from the electric outlet.**

**Never allow clips to touch each other.**

1. When hooking up the charger, attach the plug into the twist-lock receptacle on the side of the battery box or connect the clips directly to the battery on units that are not pre-wired with a plug on the side of the battery box.

### **FOR UNITS NOT EQUIPPED WITH A TWIST-LOCK, PREWIRED CHARGER PLUG FOLLOW THESE ADDITIONAL PRECAUTIONS.**

1. Check polarity of battery posts. POSITIVE (POS, P, +) battery post usually has larger diameter than NEGATIVE (NEG, N, -) battery post.
2. Determine which post of the battery is grounded (connected) to the chassis of the machine. Connect the NEGATIVE (black) clip from the battery charger to the machine chassis, as far away from the battery as possible.
3. The POSITIVE (red or white) clip from the battery charger to the POSITIVE (POS, P, +) post of the battery.
4. When making each connection, twist or rock clip back and forth several times to make a good connection and to reduce the risk of a clip slipping off and creating a spark. Do not twist or rock clip on the battery after the second clip connection is made.
5. When disconnecting the charger, disconnect AC cord from the electrical outlet before removing any clips from the battery or chassis.

**IF THESE INSTRUCTIONS ARE NOT CLEAR  
OF IF THERE ARE ANY QUESTIONS,  
PLEASE CONTACT SOUTHWORTH PRODUCTS CORP.**

**TELEPHONE: (800) 743-1000**

**FAX: (207) 797-4734**

**E-mail: [service@SouthworthProducts.com](mailto:service@SouthworthProducts.com)**

**[www.SouthworthProducts.com](http://www.SouthworthProducts.com)**

## OPERATING INSTRUCTIONS

1. Before operating the lift, read and understand this entire section.

### DANGER!

The lift may use a power supply of up to 575 Volts AC. This voltage can kill. **Do not work with the electrical parts unless you are a qualified electrician!**

2. Locate the lift on a firm, flat surface as shown in Figure 2. Stationary lifts should be lagged to the floor.

### WARNING!

If you place the lift on a soft surface, it may tip over, especially when it is loaded or raised. Someone may be hurt, and the lift and load may be damaged.

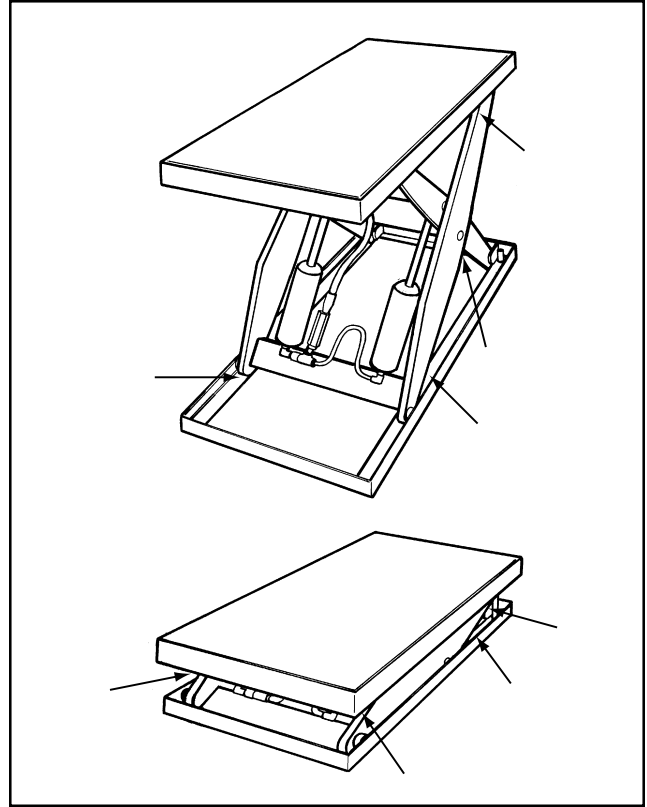
3. Load the lift correctly.

- Be sure that the load weighs no more than the maximum rated for the lift. The maximum rated load is shown on the platform skirt.

### WARNING!

Do not try to lift a load that exceeds the maximum rating. If you try this, the lift may fail suddenly. Someone may be hurt, and the lift and load may be damaged.

- Place the load in the center of the lift table, as shown in Figure 4.
- Do not try to load the lift while the lift table is moving.

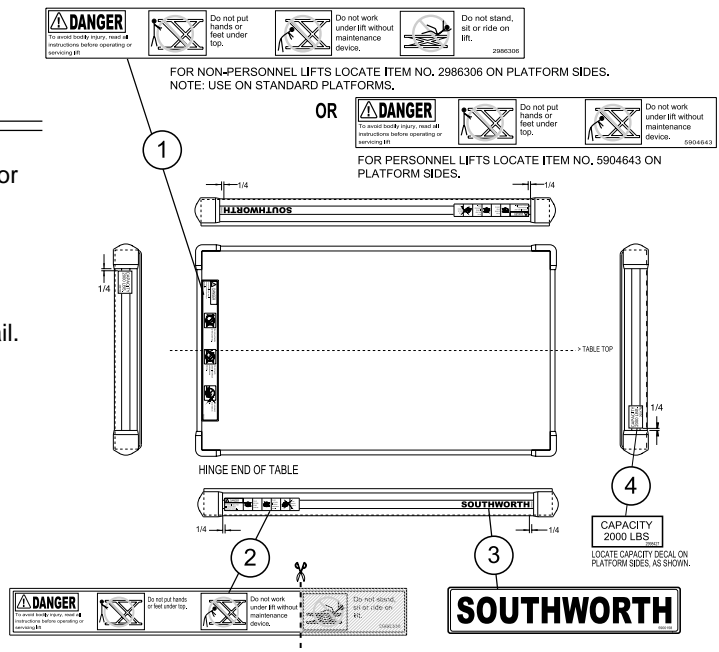


**Figure 6 - Pinch Points**

- If you are lifting pipes or other objects which may be able to roll or move, fasten them down, or chock them as shown in Figure 5.
4. Be sure all workers are clear of the lift. Remove any lumber or other material which may fall onto the lift.

### Tabletops with Comfort Edge Kits

Item	Part#	Location
1	2986306	On end of tabletop as shown on machines without handrails or
	5904643	On end of tabletop as shown on machines with handrails
2	2986307	One on each side as shown. Cut off last picture and word message if tabletop has handrail.
3	2998429	One on each side as shown.
4	Capacity decals: On platform ends, one per end as shown.	
	2998433 (500#)	2998437 (3500#)
	2998425 (1000#)	2998426 (4000#)
	2998434 (1500#)	2998442 (5000#)
	2998427 (2000#)	2998428 (6000#)
	2998435 (2500#)	5900159 (Other)
	2998436 (3000#)	



**Figure 7 - Labels and Precautionary Markings for Comfort Edge Tabletops**

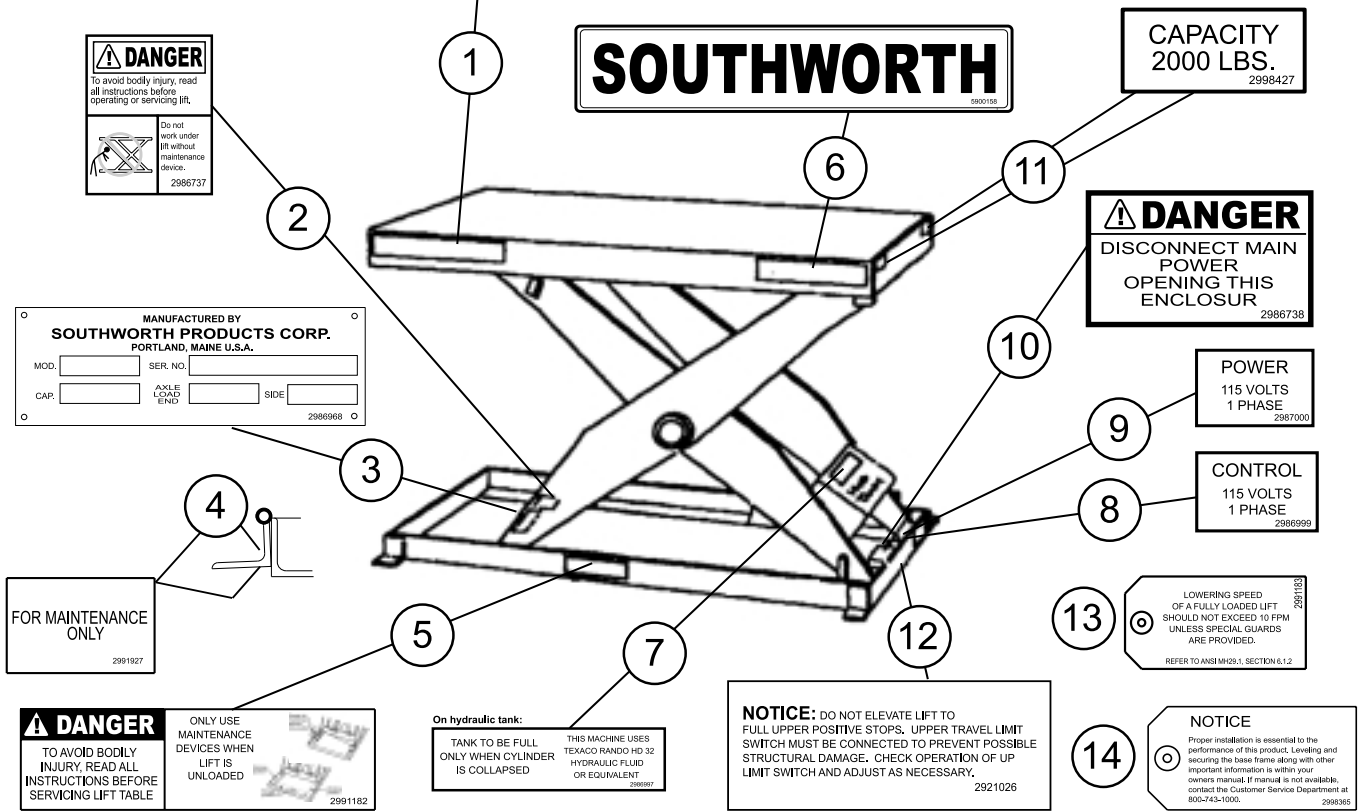
# LS Series Lift Tables

## PLATFORM PRECAUTIONARY DECALS



FOR NON-PERSONNEL LIFTS LOCATE ITEM NO. 2986306 ON PLATFORM SIDES.  
NOTE: USE ON STANDARD PLATFORMS.

FOR PERSONNEL LIFTS LOCATE ITEM NO. 5904643 ON PLATFORM SIDES.



Item	Part#	Location
*1	2986306	On both sides of platform or (use for standard platforms)
	5904643	On both sides of platform (use for platforms with handrails)
2	2986737	On lower strongback between legs
3	2986968	On lower strongback between legs
4	2991927	On both sides of maintenance devices, both sides of base
5	2991182	On both sides of base, as close to maintenance device as possible
*6	5900158	On both sides of platform
7	2986997	On hydraulic tank
8	Control decals:	
	2986999 (115/1/60)	2986998 (24/1/60)
	5900167 (110/1/50)	5900166 (24 VDC)
	Place one decal on base end plate, where the control wire exits the base.	
9	Power decals:	
	2987000 (115/1/60)	2991783 (12VDC)
	5900160 (230/1/60)	5900161 (24VDC)

Item	Part#	Location
9	2987001 (208/3/60)	5900163 (110/1/50)
	2987002 (230/3/60)	5900164 (220/1/50)
	2987003 (460/3/60)	2999416 (380/3/50)
	5900162 (575/3/60)	5900165 (415/3/50)
	Place one decal on base end plate, where power wire exits the base.	
10	2986738	On junction box cover (alt: base end plate)
*11	Capacity decals:	
	2998433 (500#)	2998437 (3500#)
	2998425 (1000#)	2998426 (4000#)
	2998434 (1500#)	2998442 (5000#)
	2998427 (2000#)	2998428 (6000#)
	2998435 (2500#)	5900159 (Other)
	2998436 (3000#)	
	Place one decal on platform ends, two per end.	
12	2921026	Machines with up limit only: Locate on end of base.
13	2991183	Fasten to flow control located on the hydraulic arrangement.
14	2998365	Fasten to flow control located on the hydraulic arrangement.

**Figure 8 - Labels and Precautionary Markings (straight skirt and bevel toe guard platforms)**

**Note: If tabletop has comfort edge refer to figure 7 on the previous page. Use other decals and locations in place of the ones above with an asterick "\*" in front of their number.**

## WARNING!

Do not use the unit to lift people unless it has been specially equipped for this purpose. A specially equipped lift will include operator protection, and a velocity fuse to keep the lift from dropping suddenly if a hydraulic line is damaged. Retrofit kits are available if you want to add these features to your lift.

## WARNING!

As the lift table moves up and down, “pinch points” are created as shown in Figure 6. Stay away from these pinch points! Part of your body or clothing may become caught, and you may be hurt.

5. To operate the lift., press and hold the “up” button to raise the lift, and “down” to lower it. If the lift does not operate right away, turn off the lift and call a qualified maintenance worker.

## WARNING!

If you hear a squealing noise from the pump, the pressure relief valve is operating. Do not continue to use the lift! The pump will overheat very quickly, and may be

permanently damaged. The relief valve is included to protect the machine operators – do not change the relief pressure setting.

6. Wait until the lift table has stopped. Unload the lift.

## WARNING!

The warning labels on the lift are there for your safety. If you find that the labels are worn or missing, or have been painted over, ask Maintenance to replace the labels before you use the lift. The labels are shown in Figures 7 and 8.

If your machine is equipped with a flush mount turntable:

## WARNING!

Do not drop the load on the turntable. If you do this while the turntable is moving, the load may shift. You may be injured, or the mechanism may be damaged. If you drop the load while the turntable is stopped, the machine may be damaged.

Stay clear of the turntable while it is rotating. As the pallet turns, a part of the load may rotate around and hit you.

## MAINTENANCE

All servicing should be done by qualified personnel. Qualified personnel should be able to read and understand wiring and hydraulic diagrams. They should be able to troubleshoot live electrical circuits safely and in accordance with accepted practice. **For safety’s sake**, if in doubt, please contact your dealer or Southworth’s Customer Service Department at (207) 878-0700 or (800) 743-1000. Before servicing the lift, read and understand this entire section and the section entitled “Operating Instructions.”

### Hazards

There are several hazards you should be aware of as you service the lift:

## DANGER!

The lift may use a power supply of up to 575 Volts AC. This voltage can kill. Do not work with the electrical parts unless you are a qualified electrician!

## WARNINGS!

- As the lift moves up and down, “pinch points” are formed as shown in Figure 6.

Keep hands, feet, and loose clothing away from these pinch points. If your hand or arm or a part of your clothing is caught, you may be hurt.

- A falling lift can cause severe personal injury. Before working under the lift, raise the lift and insert the maintenance devices, as shown in Figure 1. Do this every time you work under the lift!

## WARNINGS!

- Do not change the setting on the relief valve. If you do change the setting, this may cause a hydraulic part to fail. The lift may drop suddenly. Someone may be hurt, and the lift and the load may be damaged. The hydraulic parts in the lift are designed to handle a certain amount of pressure. The relief valve is set to relieve this pressure before it becomes too great. The relief valve has been included for the protection of all of the workers who use the lift.

- Release of fluids under high pressure can cause personal injury. Before you open any part of the hydraulic system, be sure to release the hydraulic pressure.

# LS Series Lift Tables

- The warning labels on the lift are there for the safety of the operators. See Figures 7 and 8. If the labels are worn or missing, or have been painted over, replace them before releasing the lift for operation.

## Routine Periodic Maintenance

### Every month:

- Visually inspect the leg rollers, center pivot bushings and pins, cylinder clevis pins and bushings, and the leg hinge pins and bushings for signs of wear. Contact Southworth for instructions for repair of the center pivot pins and bushings.

#### WARNING!

**If you are going to repair the center pivot pins and bushings, you must support the lift table in a special way. Each set of leg plates, on both sides of the unit, must be clamped together firmly, using large C-clamps. You cannot use the maintenance devices shown in Figure 1 – with the pivot pins removed, they will not support the table top. If you do not support the lift table correctly, the top may drop suddenly when you remove the pivot pins. Please contact Southworth for instructions.**

- Apply oil or WD-40 to the parts listed in the last step.

NOTE: Although the bearings are “lifetime lubricated” their performance may be extended by additional periodic lubrication.

- Check the level and appearance of the hydraulic fluid. First, **raise the lift and insert the maintenance devices, as shown in Figure 1.** On most models, when the lift is fully elevated, the oil should be about 3/4 inch above the bottom of the tank. Use a dipstick to check the oil level, and add oil as necessary. Change the oil if it has darkened, or feels gritty or sticky.

#### CAUTION!

It is important to use hydraulic fluid with the correct grade and properties. See the hydraulic oil specification in this manual, Table 2.

### Every six months or 500 hours of operation, whichever comes first:

- **Raise the lift and insert the maintenance devices, as shown in Figure 1.**
- Check all of the hydraulic fittings and hoses, and repair the connections as necessary. Occasionally the fittings can be worked loose by the vibrations from the power unit.

#### WARNING!

**If a hydraulic fitting becomes loose, or if a hydraulic hose breaks, the hydraulic fluid may escape from the system under pressure. If the lift is raised when this happens, it can drop quickly. Someone may be hurt, or the lift or load may be damaged.**

- The clear plastic vent line and the cylinder rod(s) should be free of hydraulic fluid. If you find much fluid in either place, the cylinder seals may be leaking. (It is also possible the tank may be overfilled.) See the section on “Repacking Southworth Cylinders.”
- Disassemble the down valve as shown in Figure 15. Blow the valve plunger clean with compressed air. Reassemble and reinstall.
- Drain and discard the hydraulic fluid. The suction filter is in the tank, at the point where the suction line runs out to the pump. Unscrew the hydraulic filter.
- Blow the filter clean. Reinstall the filter in the tank and reassemble the hydraulic line.
- Refill the tank with new hydraulic fluid.

#### CAUTION!

If you continue to use fluid after it has “worn out,” the moving parts in the system will wear more quickly.

- Be sure all of the warning labels are in position and legible. The labels are shown in Figures 7 and 8. **The warning labels are intended to protect your workers.** If the labels are missing, or if they have been painted over, replace them.

## Minimum Required Maintenance for Units with High Cycle Package

- Every 10,000 cycles, visually inspect the entire lift. Replace all worn or broken parts. Lubricate all pivot points and clean the roller track.
- Every 30,000 cycles, visually inspect the entire lift. Check the motor starter contacts and limit switches. Clean and lubricate all pivot points. Inspect for worn or broken parts, and replace as necessary.
- Every 90,000 cycles, visually inspect the entire lift. Check the hydraulic tank and the hydraulic lines. Clean and lubricate all pivot points. Inspect for worn or broken parts, and replace as necessary. Repack the cylinder(s), and replace the hydraulic oil and filter.

NOTE: If lubrication points will not take grease, the load may have to be removed from the platform, ensure the grease fittings are not plugged and will take grease, or the weight of the lift may need to be removed from the greaseable joint. A fork truck or overhead crane may

be necessary to remove any weight off of the greaseable joints. Contact Southworth's Service Department for further instructions if the machine is still unable to accept grease.

## Maintenance for Units with Flushmount Turntable

NOTE: It is normal to see some wear on the plate under the turntable. After a short "break-in" period usually 100 to 200 revolutions, a work hardened wear strip will develop, and further wear should be minimal.

Every week, make a general walk-around inspection. Remove any dirt and debris from the turntable top. Clear the gap between the table and the turntable. (An air hose may be used.)

If excessive force is used to rotate the turntable, this may be caused by a lack of lubrication, contaminated bearings, or dirt. To correct the problem, remove the turntable and inspect the mechanism. Clean and lubricate the parts as described in the following sections.

### Removing the Turntable Top

NOTE: These instructions apply only to units with the flushmount turntable.

1. Put the lift in the fully-lowered position.
2. Unplug the machine.
3. Use a pair of snap-ring pliers to remove the snap ring in the center of the turntable.
4. Use a lever to lift one edge of the turntable. Lift the turntable away from the machine.

(The turntable weighs about 75 lbs. You will need at least two people to lift this part safely. Be sure to wear heavy gloves when performing this job.)

5. If necessary, you can now remove the carrier plate. The steel balls used in the machine can remain in the lower part of the machine. Do not remove the balls unless you want to degrease the bearings - it can be time consuming to reassemble this part of the machine.
6. In the 43" diameter turntable there are 72 balls. In the 20" diameter turntable there are 48 balls. They are standard chrome-plated steel balls.
7. To reassemble the machine, reverse the steps listed above. **Be sure that every bearing position has a ball.** Check to see that the locking device is intact.

### Inspecting and Lubricating the Turntable

NOTE: These instructions apply only to units with the flushmount turntable.

1. Remove the turntable as described in the last section.
2. Lift out the carrier plate. Collect the steel balls (48 balls for the 20" dia. turntable, 72 balls for the 43" dia. turntable).
3. Degrease the carrier plate and the steel balls.
4. Inspect the steel balls for signs of wear. Check several balls for discoloration or breakdown of the chrome layer.
5. Set the carrier plate back in position. **Place each of the balls in one of the bearing positions.** Be sure that every bearing position has a ball. The machine uses the large number of bearings to spread out the weight of the load. If some of the balls are missing, the machine will not work properly, and may wear more quickly.
6. Pack some grease inside the opening of each bearing position on the carrier plate.
7. Work some grease around the center pivot pin and snap ring.
8. To reassemble the machine, reverse the steps listed above.

## Maintenance for Units with Air Motors

On this type of unit, the air motor is used to power the hydraulic pump. (See Figure 23 - hydraulic diagram.) When the lift is raised, a valve sends compressed air to the air motor. The air motor powers the pump and provides hydraulic power for the unit. When the lift is lowered, an air-operated down valve allows the hydraulic fluid to escape from the cylinders.

The vanes in the rotary-type air motor take up their own wear, and will last 5,000 to 15,000 hours of operation. (The actual service life depends on the operating speed, method of oiling, operating pressure, and the precautions taken in maintaining the machine.) The type of shaft seal used will not withstand pressures of more than 100 psi.

An automatic airline lubricator must be installed in the airline just ahead of the air motor. (The filter, regulator, and lubricator are not supplied by Southworth.) The lubricator must be adjusted to feed one drop of oil for every 50 to 75 cfm of air going through the motor. This lubrication is necessary to reduce friction on all internal moving parts, and to prevent rust.

The starting torque of the air motor is greater than the running torque. This could vary depending on the position at which the vanes stop in relation to the air intake port. It is advisable to use a pressure regulator or a simple shut-off valve to obtain the desired power,

## LS Series Lift Tables

speed and torque, and to conserve air.

### CAUTION!

Do not allow the air motor to “run free” at high speed with no load. This can cause buildup of excessive heat and loss of internal clearances, and can damage the motor quickly.

If the motor is sluggish or inefficient, try flushing it with solvent. To flush a motor, disconnect the airline and muffler. Add several teaspoons of solvent directly into the motor. (Southworth recommends the following solvents for this purpose: Gast Flushing Solvent AH255, Dem Kote 2X726, and Loctite Safety Solvent.) Rotate the shafts by hand in both directions for a few minutes. Reconnect the airline and gradually increase the air pressure and flow until there is no trace of the solvent in the exhaust air. Re-lubricate the motor with a squirt of oil in the chamber.

## TROUBLESHOOTING CHECKLIST

All servicing should be done by qualified personnel. Qualified personnel should be able to read and understand wiring and hydraulic diagrams. They should be able to troubleshoot live electrical circuits safely and in accordance with accepted practice. **For safety’s sake**, if in doubt, please contact your dealer or Southworth Products Corp.

Before servicing the lift, **read and understand this entire section and the section entitled “Operating Instructions.”**

### WARNING!

**Before working underneath the lift, always raise the lift and insert the maintenance devices, as shown in Figure 1. Failure to do so may result in damage to the lift and severe personal injury!**

### If the lift will not raise:

#### CAUTION !

Do not continue to hold the “up” button for more than 2 or 3 seconds. You may damage the pump.

1. Check the actual weight of the load. The rated capacity of the lift is shown on the table skirt.

#### WARNING!

**Do not change the relief valve setting. This valve has been included for the protection of workers who install, use, or service the lift. If it is ever necessary to repair or reset**

**the valve, contact Southworth Products Corp. for instructions.**

2. If the motor is not running, check the main disconnect switch, the fuse(s) and the wiring to the motor.
3. Using an external lifting mechanism, such as a crane or fork lift, **raise the lift and insert the maintenance devices as shown in Figure 1.** Be sure to lift the hinged end of the table top.
4. The hydraulic oil level may be low. When the lift is raised as far as possible, the oil should be about 3/4 inch above the bottom of the tank. (The exact level varies with different models, especially on models with tanks that tip as the lift elevates.) Use a dipstick to check the oil level.
5. If your lift has an optional up limitswitch, the lift may have reached this upper limit. If the switch is out of adjustment, the lift may not be able to raise completely. Readjust the switch if necessary.

#### WARNING!

**Do not disconnect the up limitswitch. Instead, loosen the adjusting screw, and change the position of the arm. If you do disconnect the switch, when the lift platform moves up, it may not stop at the correct point. If the platform rises above the normal stopping point, the frame of the unit may be damaged. People working nearby may be hurt.**

6. On a lift with a three-phase motor, the motor may be running backwards. If the motor has been wired correctly, the lift should start moving 2 or 3 seconds after you press the “up” button. If it doesn’t, try reversing any two electrical leads.
7. On a lift with a three-phase motor, the motor may be “single phasing.” When this happens, the motor hums, but does not turn. If this is the case, one lead of the three-phase line has been interrupted. Check the motor wiring and line fuses.
8. The motor voltage may be too low. Check the voltage at the starter when the motor is under load. The supply voltage should be within  $\pm 10\%$  of the rating.
9. On a lift with an external power unit, the tank vent may be plugged. You must remove the solid plug from the tank and insert the vented plug. The vent line must be clear.
10. The suction filter may be clogged. Clean the suction filter as described in the section on “Periodic Maintenance.”
11. A vacuum leak may be allowing air into the suction line, causing cavitation (loss of suction) in the pump. Check all fittings in the suction line, and repair as necessary.

## CAUTION!

If cavitation is allowed to continue, the pump may be damaged, and may have to be replaced.

12. For the lift to raise, the down-valve must be de-energized and fully closed. Check for a problem with the wiring to the down-valve. Check the solenoid in the valve with a volt meter. The valve must be clean and free to operate. To check this, remove the solenoid and then the valve. Look for contamination which could block the valve action. Clean the valve plunger with kerosene, then blow it clean with compressed air. The expansion nut which holds the solenoid should be finger tight only!
13. If the pump has been changed, the coupling may not have been installed. See the pump assembly in Figure 15.

### If the lift elevates, but fails to hold a load:

1. **Raise the lift and insert the maintenance devices, as shown in Figure 1.**

#### WARNING!

**Failure to insert the maintenance devices may result in damage to the lift and severe personal injury!**

2. The check valve may be leaking. Dirt on the valve seat will prevent the valve from closing fully. The check valve is mounted in the base of the pump housing, as shown in Figure 15. Remove the check valve cap and inspect the valve for dirt or metal chips which may be preventing it from closing. You may be able to restore the seal by lightly rapping the ball into the seat using a 1/4" diameter rod and a small hammer.
3. The down-valve may be energized. While the lift is holding a load, the down-valve should be de-energized and fully closed. Check the solenoid in the valve with a volt meter. The valve must also be clean and free to operate. To check this, remove the solenoid and then the valve. Look for contamination which could block the valve action. Clean the valve plunger with kerosene, then blow clean with compressed air. The expansion nut which holds the solenoid should be finger tight only!
4. The cylinder(s) may be leaking. Look for oil on the cylinder rod(s) and in the vent line. (This may also occur if the oil tank has been overfilled.) If you find much oil in either place, and the tank is not overfilled, the cylinder(s) need to be repacked. See the instructions in this manual on "Repacking Southworth Lift Cylinders."

### If the lift fails to lower:

1. **Insert the maintenance devices, see Figure 1.**

#### WARNING!

**Failure to insert the maintenance devices**

**may result in damage to the lift and severe personal injury!**

2. The down valve may be de-energized. When the lift is lowering, the down valve should be energized and fully open. Check the solenoid in the valve with a volt meter. The valve must also be clean and free to operate. Remove the solenoid, then the down valve. Look for contamination which could block the valve action. Clean the valve plunger with kerosene, then blow it clean with compressed air. The strainer screen over the lower part of the plunger must be clean. See Figure 15. Before reassembly, depress the plunger manually several times to be sure it moves freely. The expansion nut that holds the solenoid should be finger tight only!
3. The flow control may need to be adjusted. The flow control must be partially open to allow the oil to return from the cylinder(s). It is important that you follow these steps when adjusting an internal flow control:

- **Raise the lift and insert the maintenance devices, as shown in Figure 1.**
- If you want the lift to lower more slowly, turn the control clockwise up to 1/4 turn at a time. If you want the lift to lower more quickly, turn the control counterclockwise up to 1/4 turn. Do not move the control more than 1/4 turn at a time.
- Remove the maintenance devices, and check the speed as the table lowers.
- Every time you want to change the adjustment again, raise the table again and insert the maintenance devices as shown in Figure 1.

#### DANGER!

**Do not try to adjust the flow control while pressing the "down" button. If you try this, the lift table may drop suddenly, and you may be hurt.**

If the steps listed above do not solve the problem, please call the Southworth's Customer Service Department.

### Repacking Cylinders

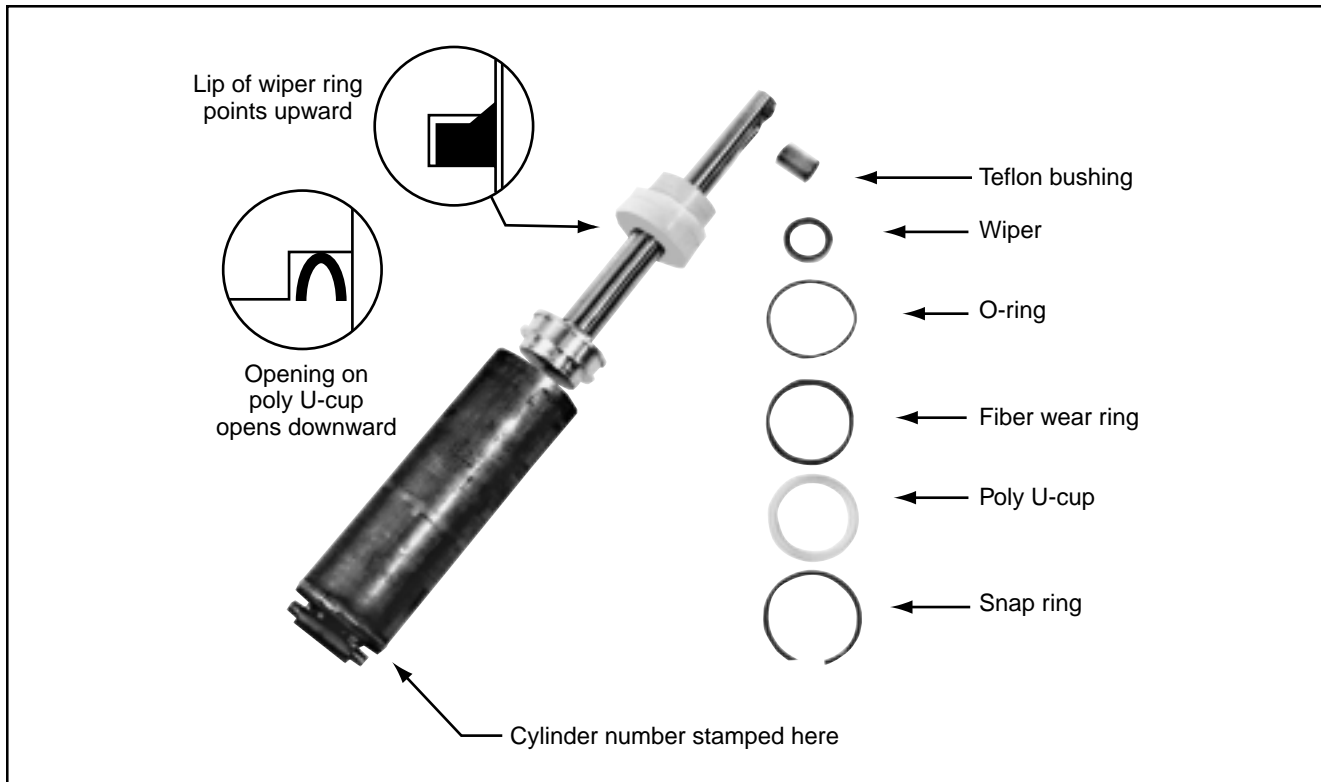
This section will tell you how to repack an "H-style" cylinder, shown in Figure 9. This type of cylinder is exclusive to Southworth, and repacking kits are only available through Southworth. To order a repacking kit, please call the Parts Department at (207) 878- 0700 or (800) 743-1000. When ordering, specify the model number and serial number of the lift, and the cylinder number(s), as listed on the base of the cylinder(s).

Before beginning this procedure, **read and understand this entire section.**

#### WARNING!

**Before working underneath the lift, always raise the lift and insert the maintenance**

## LS Series Lift Tables



**Figure 9 – H-Style Cylinder**

**devices, as shown in Figure 1. Failure to do so may result in damage to the lift and severe personal injury!**

1. Before you disassemble the old cylinder, be sure you have these items on hand:
  - A repacking kit. Parts may be damaged when you disassemble the cylinder. You should have replacement parts on hand so you can reassemble the lift and use it immediately.
  - A supply of new hydraulic oil. Contaminated oil may damage the new packing.
  - A container to catch the used oil.
  - A clean place to work. Choose a place which will not be damaged if you spill some oil.
2. **Raise the lift and insert the maintenance devices, see Figure 1.**
3. Turn off electrical power at the main disconnect or circuit breaker, or unplug the machine. This will prevent the lift from moving accidentally while you are working on it.
4. Disconnect the cylinder supply line at the pump, and place the end into a container to collect the used oil.
5. Disconnect the vent line at the cylinder(s).
6. At the top end of the cylinder rod, remove the "keeper," and drive out the clevis pin. Push the rod back

into the cylinder to drive the hydraulic fluid out through the hose into the container. You may use air pressure at the vent hole to do this. Disconnect the hydraulic line(s) from the cylinder(s). Lift the cylinder(s) out of the lift. Be careful the cylinder is heavy!

7. Figure 9 shows the parts inside a lift cylinder. At the upper end of the cylinder, remove the snap ring. Pull the rod and piston all the way out of the cylinder. This assembly is heavy -- be careful not to drop it as it comes free.
8. Remove the press-fit bushing from the hole at the upper end of the cylinder rod.
9. Look for deformation around the hole at the clevis end of the cylinder rod. If necessary, clean up the rod diameter with a file to allow the rod bearing to slide off without damage.
10. Remove the plastic rod bearing from the cylinder rod. Observe how the wiper ring sits in the rod bearing. Remove the wiper ring and the O-ring from the rod bearing. Do not try to remove the aluminum piston from the cylinder rod, as this will damage the assembly. Remove the poly U-cup and the fiber wear ring from the piston.
11. Check the vent plug, and clean it if it appears dirty.

**CAUTION!**

While reassembling, it is very important to keep all of the parts free of dirt, dust, metal chips,

water, and other contamination. Most of the problems with hydraulic systems are caused by contamination in the oil.

12. Clean the piston surfaces, and install a new fiber wear ring. Install a new poly U-cup seal, with the open part of the seal facing down.

13. Clean all of the surfaces on the rod bearing. Install a new O-ring and wiper. Replace the rod bearing assembly on the rod.

**CAUTION!**

Be careful not to install the wiper backwards. The lip on the wiper should point upwards, as shown in the detail in Figure 9.

14. Clean the bore of the cylinder tube thoroughly. Inspect the bore of the tube for scratches that run up and down, along the length of the cylinder. If you do see any scratches, hone the inner surface of the cylinder. Be sure to clean the tube thoroughly after you do this.

15. Lubricate the seal and piston with clean grease or oil. Carefully insert the piston and rod back into the cylinder. Be very careful not to pinch or tear the poly U-cup as the piston passes the shoulder inside the cylinder. It is helpful to tip the rod assembly and twist it as you slide it into the cylinder.

Once the piston is inside the cylinder, it should slide easily.

**CAUTION!**

If the poly U-cup is pinched or torn during reassembly, the piston may not maintain pressure as designed.

16. Slide the rod bearing into the cylinder. Install a new snap ring to hold the rod bearing in place. Replace the bushing or install a new one in the top of the cylinder rod.

17. Install the cylinder in the lift. Replace the clevis pin and “keeper.” Reconnect all of the hydraulic lines and the vent line.

18. At the start of the packing process, you drained the cylinder(s) into a container. Replace this used oil with an equal amount of fresh oil. Be sure to reinstall the vent plug when you’re done.

19. Turn on the electrical power and press the “up” button. The pump will self-prime. After a few seconds, the cylinder should lift the table off the blocks. Remove the maintenance devices. Cycle the lift up and down a few times to remove air pockets. Check for leaks.

20. Raise the lift and check the oil level with a dipstick. The oil should be about 3/4 inch above the bottom of the tank.

21. If you have spilled any oil, clean it up.

**DANGER!**

**Spilled hydraulic oil is slippery, and may present a fire hazard. Always clean up any spilled oil.**

## Replacing Leg Rollers

Please contact Customer Service at Southworth Products Corp. for instructions for your model and application at (207) 878-0700 or (800) 743-1000.



**Figure 10 – Parts Identification, Side View**

# LS Series Lift Tables

## Ordering Replacement Parts

Southworth has carefully chosen the components in your lift to be the best available for the purpose. Replacement parts should be identical to the original equipment. **Southworth will not be responsible for equipment failures resulting from the use of incorrect replacement parts or from unauthorized modifications of the machine.**

Southworth will gladly supply you with replacement parts for your Southworth lift. Key parts are identified in Figures 8 through 15. With your order, please include the model number and the serial number of the lift. You can find these numbers on the name plate, which is located on the crossbar at the base of the cylinder(s). When you are ordering parts for a cylinder, also include the cylinder number. This is stamped on the base of the cylinder housing.

To order replacement parts, please call the Parts Department.

Parts are shipped subject to the following terms:

- FOB factory
- Returns only with the approval of our parts department.
- Payment net 30 days (except parts covered by warranty).
- Freight collect (except parts covered by warranty).

Parts replaced under warranty are on a "charge-credit" basis. We will invoice you when we ship the replacement part, then credit you when you return the worn or damaged part.

Parts Department

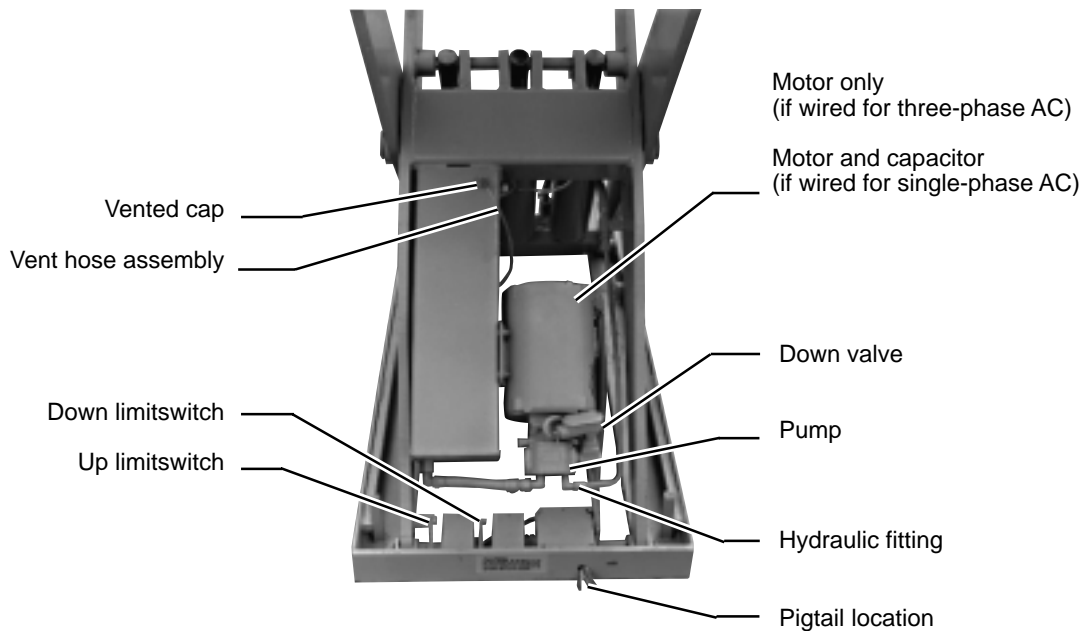
**Southworth Products Corp.**

Telephone 207) 878-0700 or (800) 743-1000

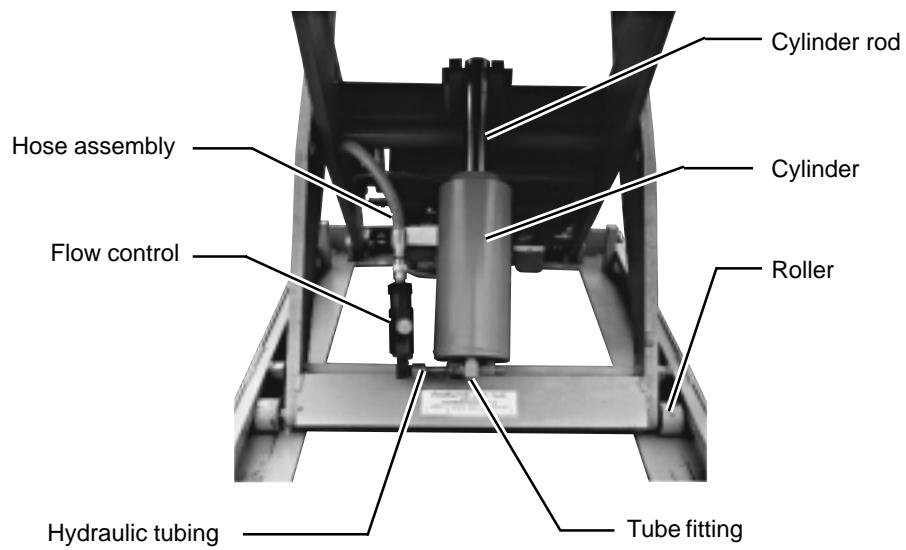
FAX : (207) 797-4734

repairparts@SouthworthProducts.com

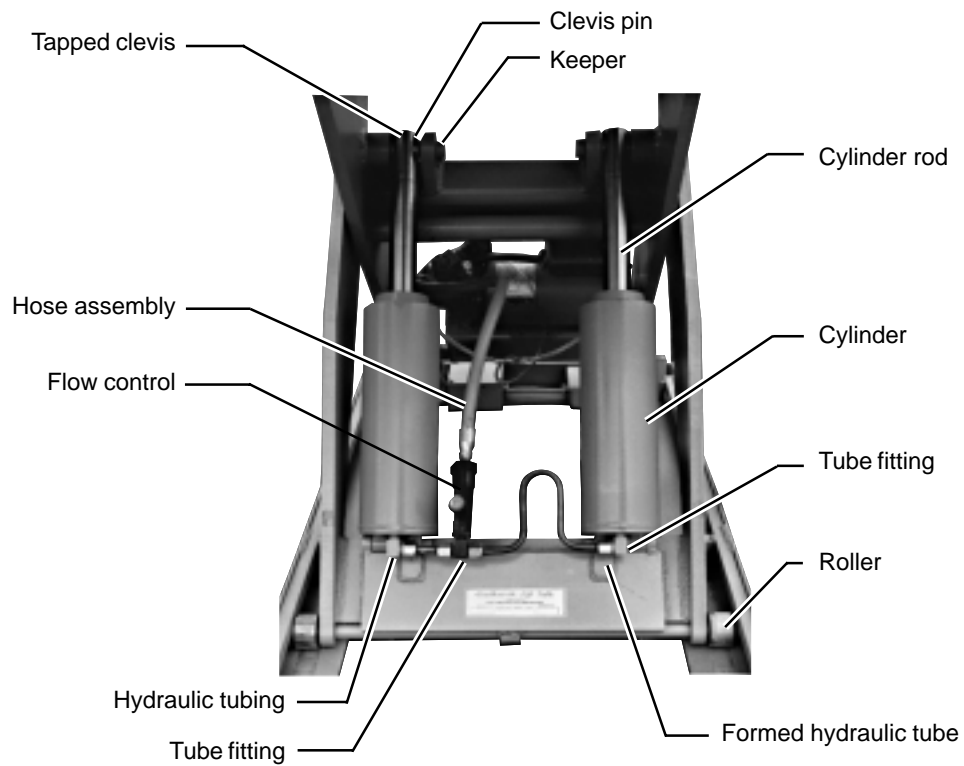
www.SouthworthProducts.com



**Figure 11 – Parts Identification, View of Motor and Pump** (The layout of components varies from model to model)

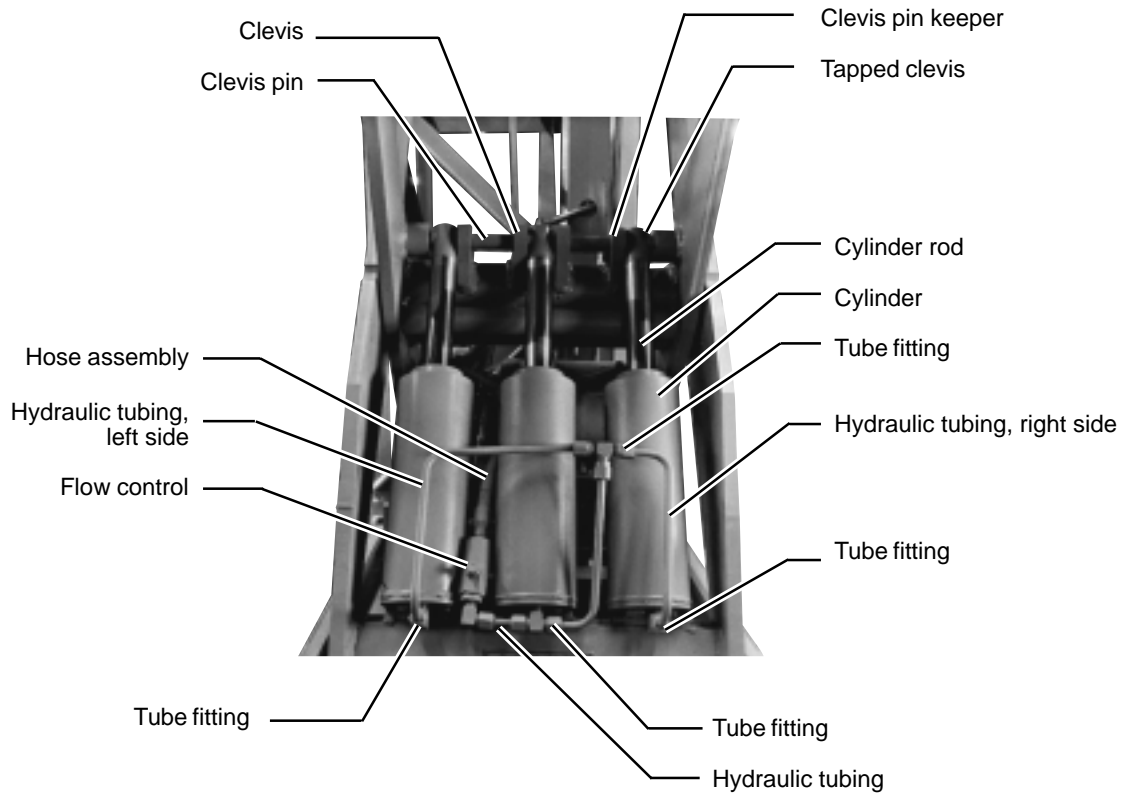


**Figure 12 – Parts Identification, LS-2 Models**

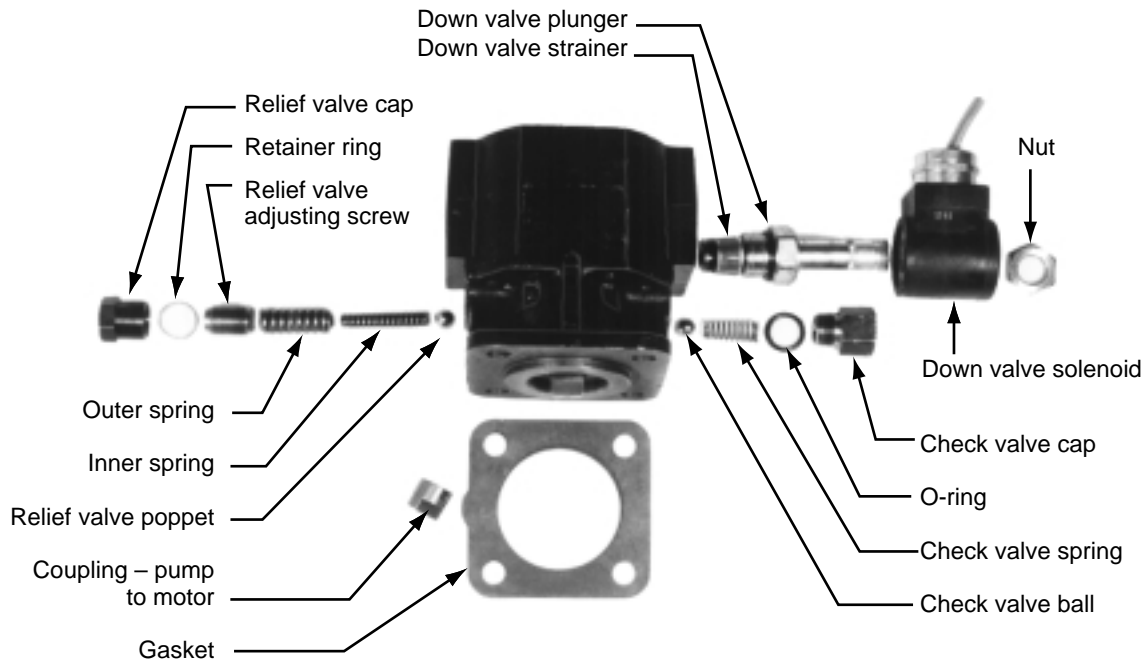


**Figure 13 – Parts Identification, LS-4 Models**

# LS Series Lift Tables

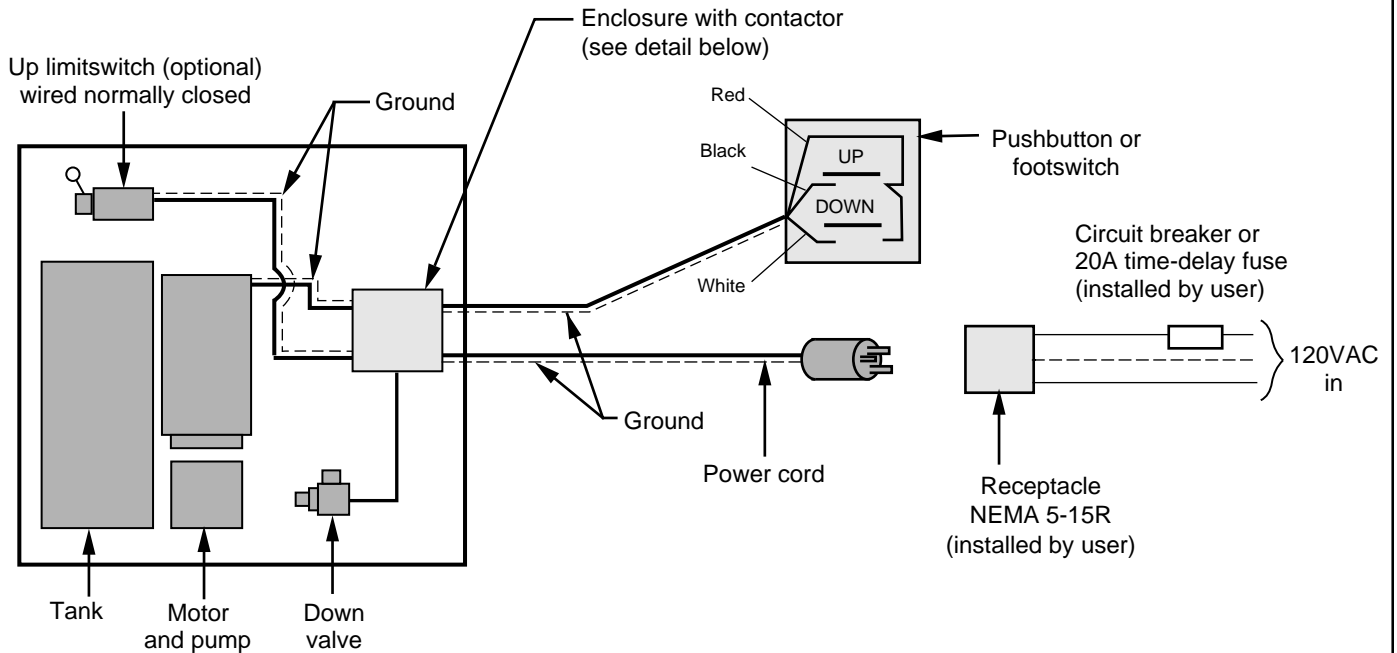


**Figure 14 – Parts Identification, LS-6 Models**



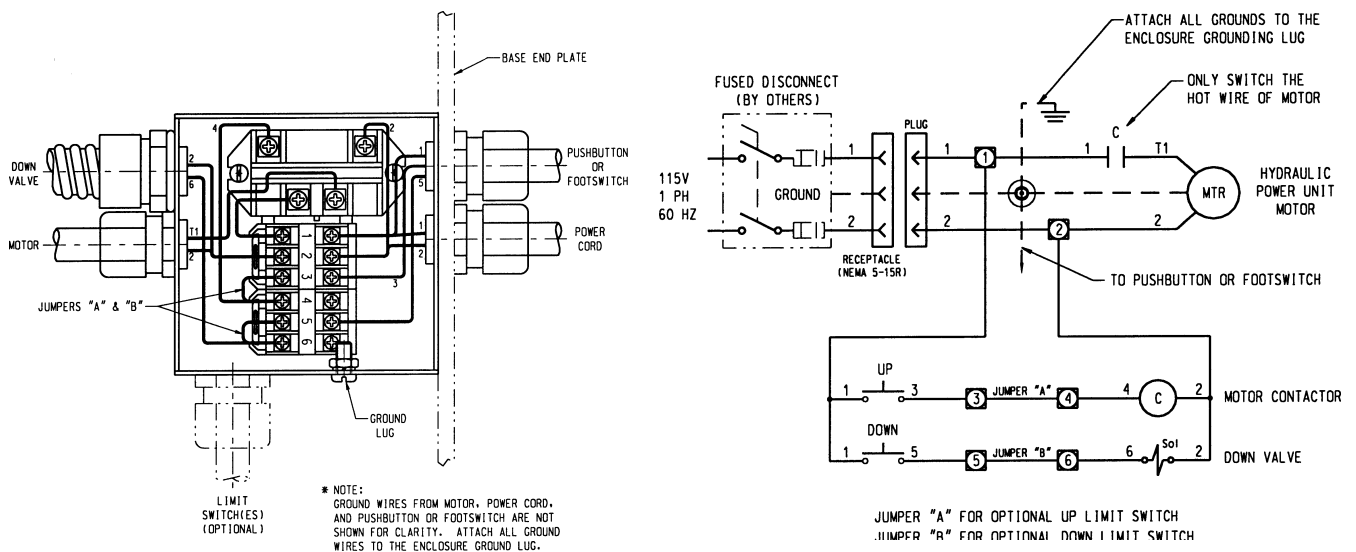
**Figure 15 – Hydraulic Pump and Down Valve**

## Electrical Connections for Single-Phase AC



**Fig. 16 - Electrical Connections, Lifts Wired for Single-Phase AC**

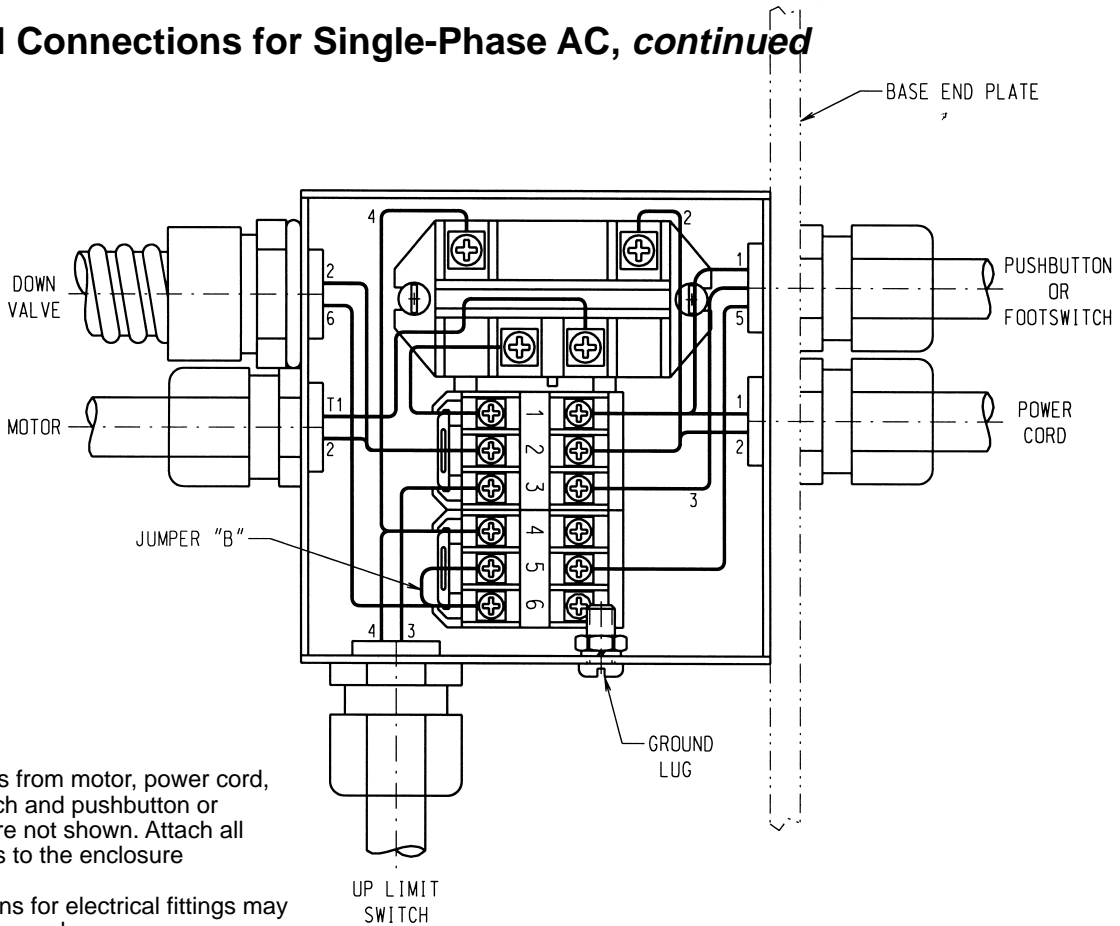
Connections shown above are for lifts operating on 120 VAC. For lifts operating on 230 VAC, a NEMA L6-15R receptacle is required. The pump, motor, and down valve may be mounted on the lift unit itself (internal power unit) or in a separate location (external power unit).



**Figure 17 - Wiring Diagram, Lifts Wired for Single-Phase AC - without limitswitch**

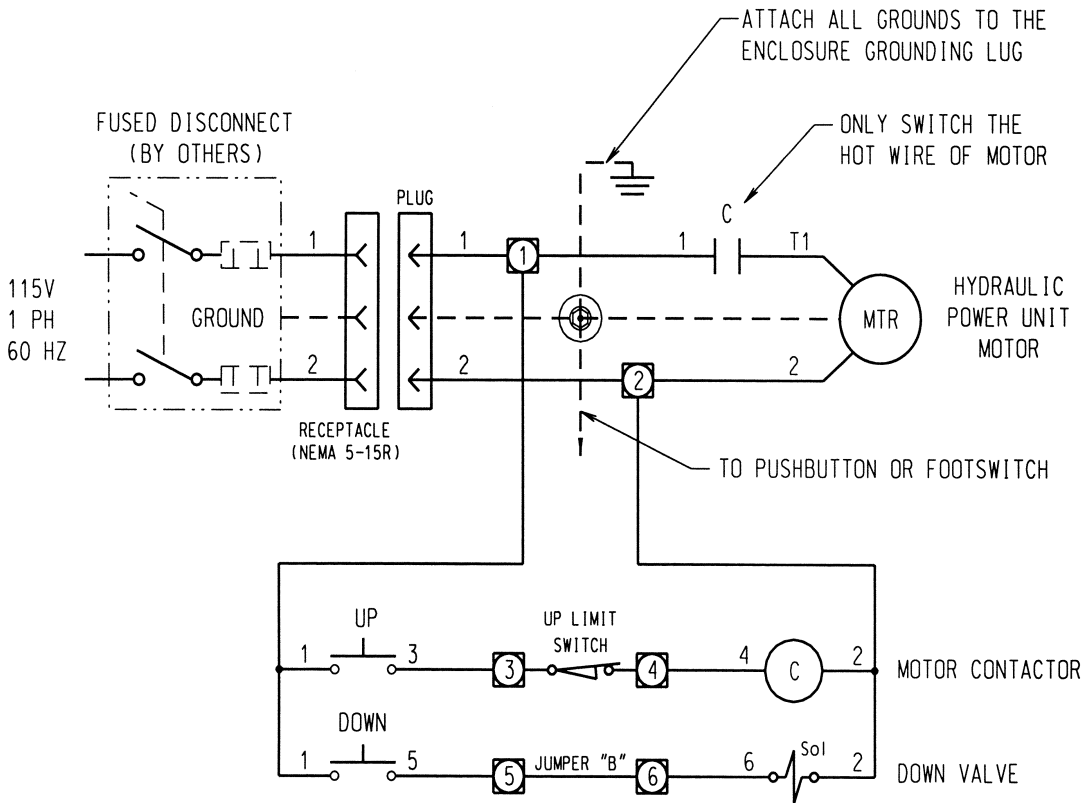
# LS Series Lift Tables

## Electrical Connections for Single-Phase AC, *continued*



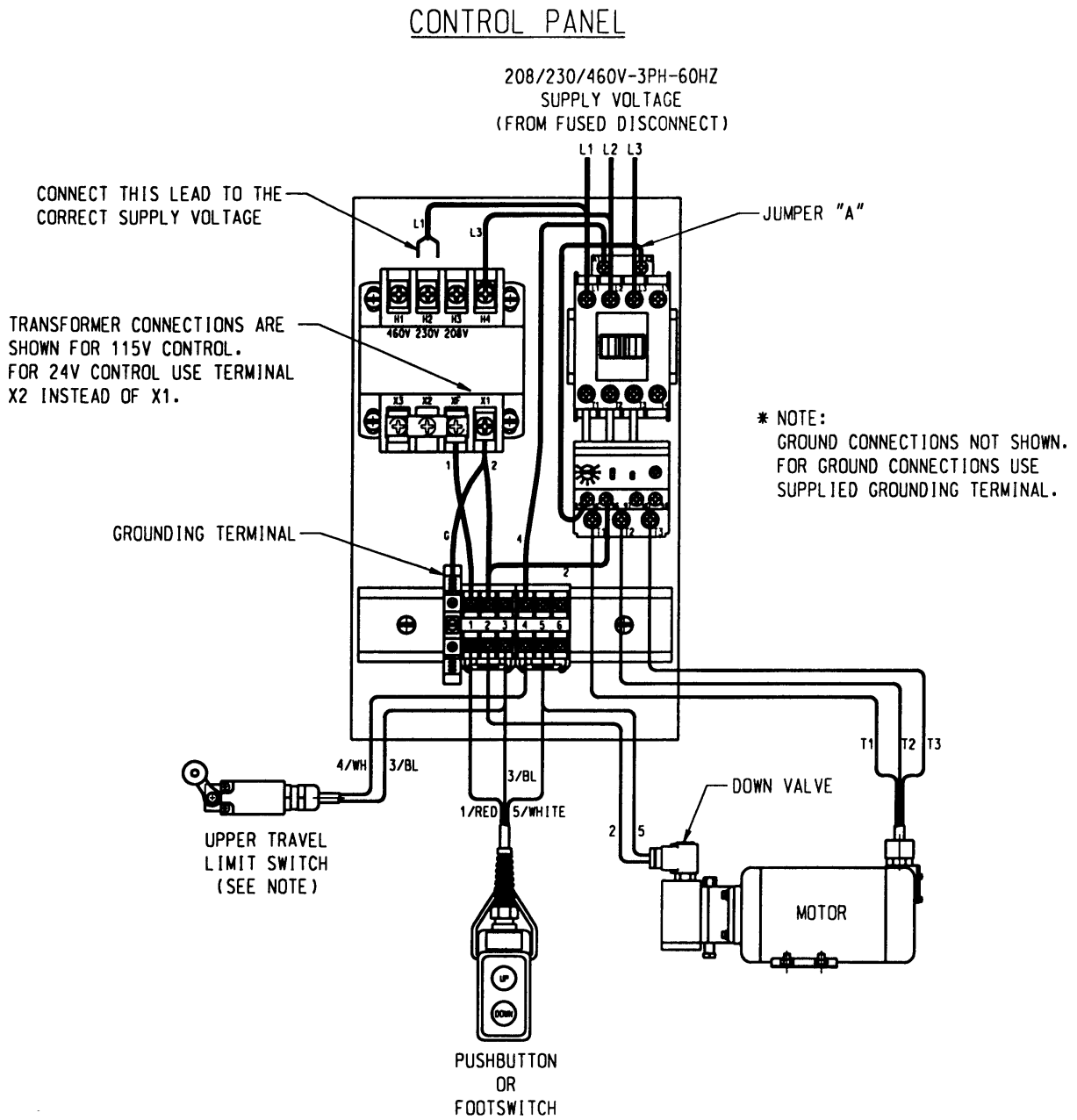
**\*NOTES:**

1. Ground wires from motor, power cord, up limit switch and pushbutton or footswitch are not shown. Attach all ground wires to the enclosure ground lug.
2. Entry locations for electrical fittings may differ from those shown.



**Figure 18 - Wiring Diagram, Lifts Wired for Single-Phase AC - with limit switch**

## Electrical Connections for Three-Phase AC



**Figure 19 – Electrical Connections, Lifts Wired for Three-Phase AC**

Connect the power and control wiring to the proper terminals located in the control panel. The pump, motor and valve may be mounted on the lift unit itself (internal power unit) or in a separate location (external power unit). The control panel may be wall mounted.

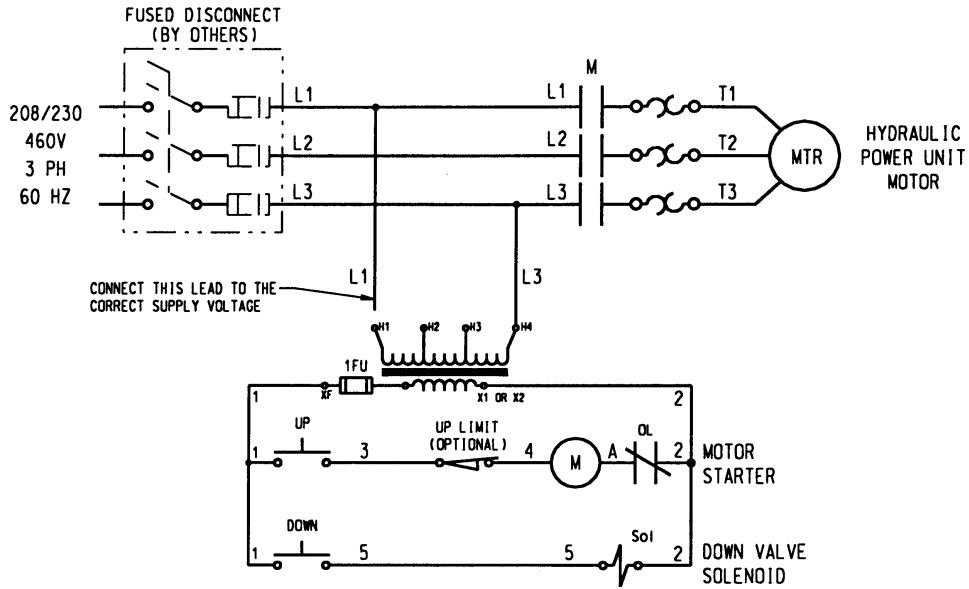
**CAUTION!**

If on power-up the motor rotates in the wrong direction, don't continue to operate the lift. You may damage the pump. To correct the problem, interchange any two of the motor leads (T<sub>1</sub>, T<sub>2</sub> or T<sub>3</sub>).

# LS Series Lift Tables

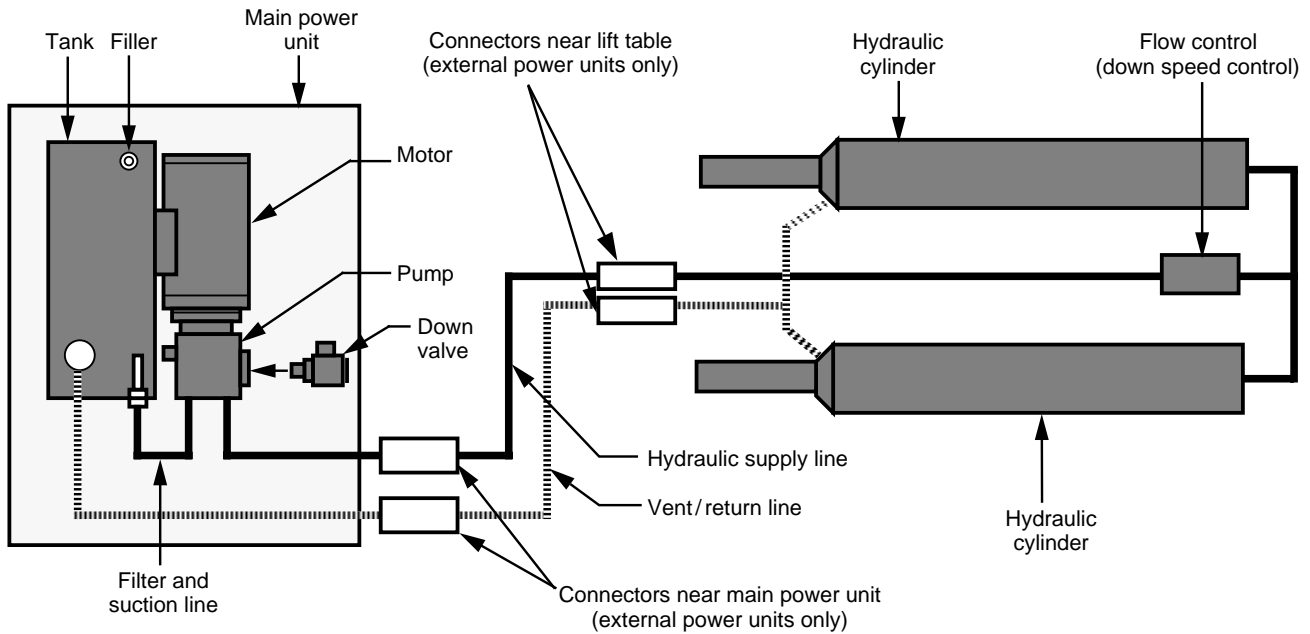
## Electrical Connections for Three-Phase AC, *continued*

### WIRING DIAGRAM

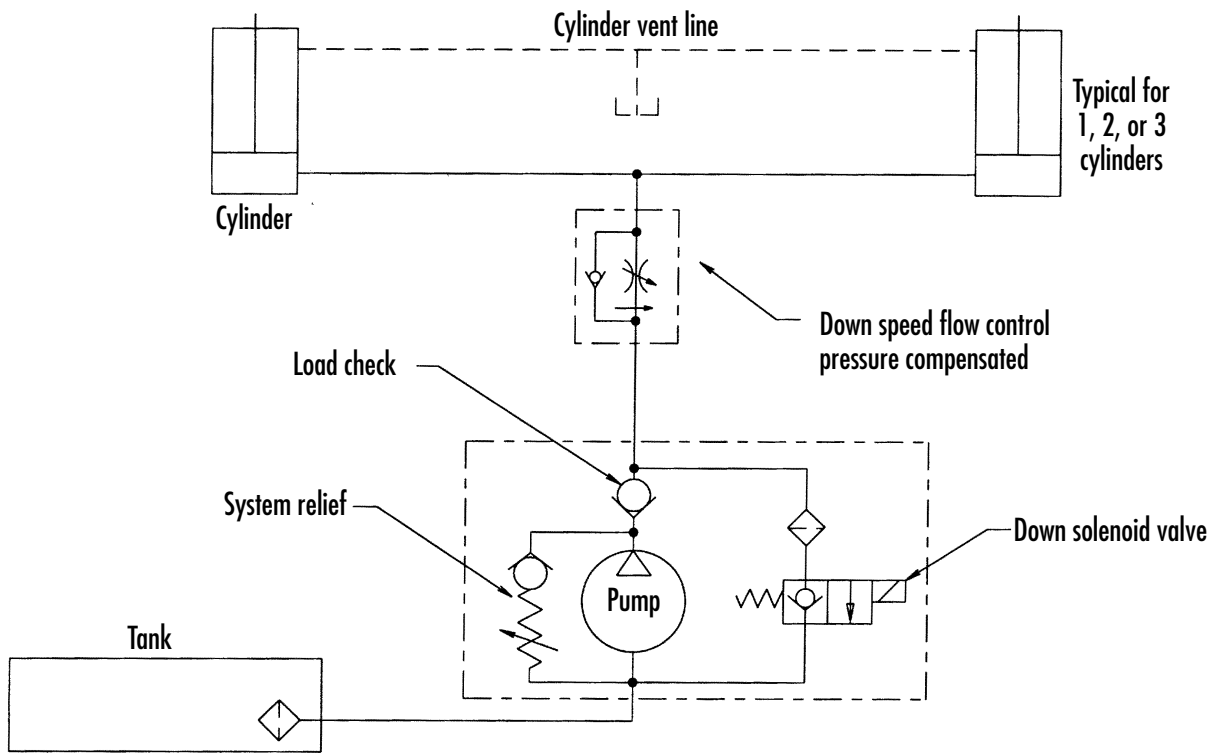


NOTE: UPPER TRAVEL LIMIT SWITCH IS OPTIONAL.  
IF LIMIT SWITCH IS ABSENT, MOVE WIRE 4  
IN PANEL FROM TERMINAL 4 TO TERMINAL 3  
AND RENUMBER AS WIRE 3.

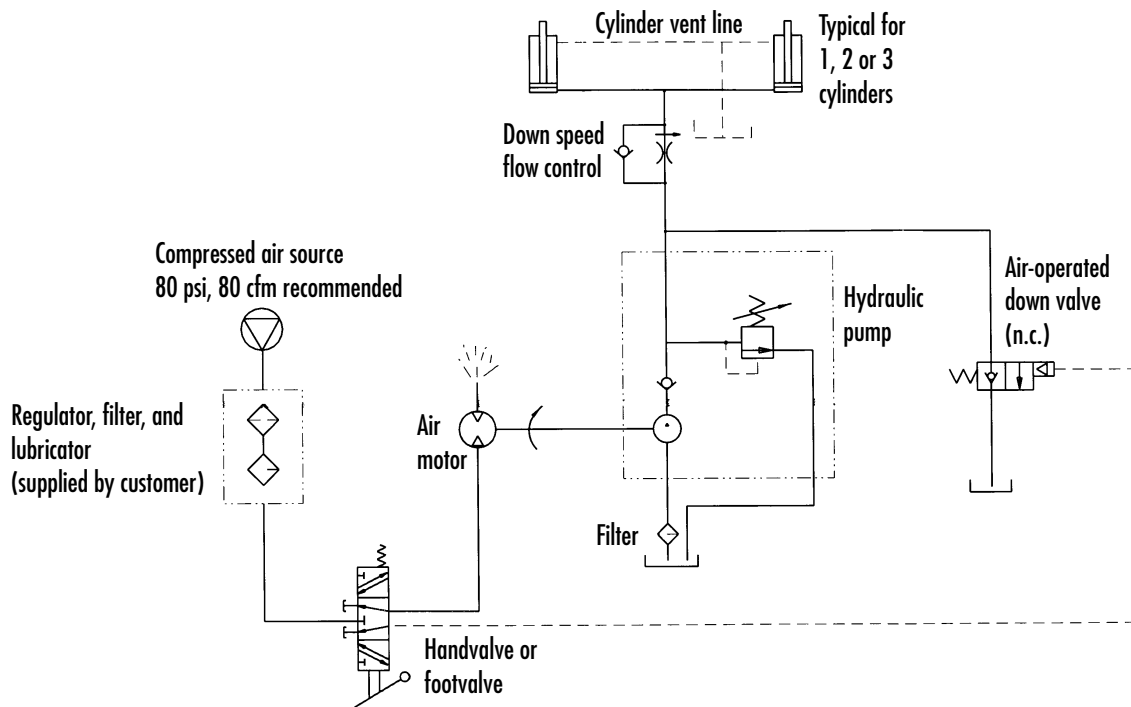
**Figure 20 - Schematic, Lifts Wired for Three-Phase AC**



**Figure 21 - Hydraulic Connections**



**Figure 22 – Hydraulic Diagram - Unit Powered by Electric Motor**



**Figure 23 – Hydraulic Diagram - Unit Powered by Air Motor**

# LS Series Lift Tables

**Table 1 – Electrical Interface, Supplied by Customer**

<i>Motor Voltage</i>	<i>Required Fuse 1.0 HP Motor</i>	<i>Required Fuse 3.2 HP Motor</i>	<i>Wire Gauge</i>
*115/1/60	20 AMP	—	12 AWG
208/1/60	20 AMP	—	12 AWG
240/1/60	20 AMP	—	12 AWG
208/3/60	10 AMP	12 AMP	14 AWG
240/3/60	10 AMP	10 AMP	14 AWG
480/3/60	5 AMP	5 AMP	14 AWG
575/3/60	5 AMP	5 AMP	14 AWG

\* This lift requires a dedicated 20 amp circuit servicing no other electrical devices.  
Do not operate this lift with an extension cord.

**Table 1 – Hydraulic Oil Specifications**

If the lift will be used at normal ambient temperatures, Southworth supplies the unit with Citgo AW 32 oil. This may be replaced by any other good quality oil with 150 SSU at 100° F and rust and oxidation inhibitors and anti-wear properties.

If the lift will be used at ambient temperatures below 0°F, use aircraft hydraulic oil. Use Type 15 aircraft hydraulic oil.

The following are equivalent to CITGO AW32:

<b>TYPE</b>	<b>MANUFACTURER</b>
DTE 24 .....	EXXON/MOBIL
NUTO H32 .....	EXXON/MOBIL
AMOCO AW32 .....	CHEVRON (AMOCO CO.)

**CAUTION!**

**It is very important to keep the hydraulic oil free of dirt, dust, metal chips, water, and other contamination. Most of the problems with hydraulic systems are caused by contamination in the oil.**



## 2 YEAR WARRANTY

Southworth Products Corp warrants this product to be free from defects in material or workmanship for a period of *two (2) years* of single shift usage from date of shipment, providing claim is made in writing within that time period. This warranty shall not cover modified designs for special applications, failure or defective operation caused by misuse, misapplication, negligence or accident, exceeding recommended capacities, failure to perform required maintenance or altering or repairing, unless alteration is authorized by Southworth Products Corp. Except as set forth herein, there are no other warranties, express or implied, including the warranties of merchantability and fitness for a particular purpose, all of which are hereby excluded.

Southworth Products Corp makes no warranty or representation with respect to the compliance of any product with state or local safety or product standard codes, and any failure to comply with such codes shall not be considered a defect of material or workmanship under this warranty. Southworth Products Corp shall not be liable for any direct or consequential damages arising out of such noncompliance.

Southworth Products Corp's obligation under this warranty is limited to the replacement or repair of defective components at its factory or another location at Southworth Products Corp's discretion. This is buyer's sole remedy. Except as stated herein, Southworth Products Corp will not be liable for any loss, injury or damage to persons or property, nor for direct, indirect, or consequential damage of any kind, resulting from failure or defective operation of said product.

This warranty may be altered only in writing by Southworth Products Corp, Portland, Maine.



**SOUTHWORTH PRODUCTS CORP**  
P.O. Box 1380, Portland, ME 04104-1380  
Telephone: (800) 743-1000 • (207) 878-0700  
Fax: (207) 797-4734  
[www.SouthworthProducts.com](http://www.SouthworthProducts.com)

JANUARY 2003