

SOUTHWORTH

Hydraulic Lift & Tilt Owner's Manual



SOUTHWORTH PRODUCTS CORP

PO Box 1380, Portland, ME 04104-1380

Telephone: 1-800-743-1000 or 207-878-0700

Fax: 207-797-4734

www.SouthworthProducts.com

service@SouthworthProducts.com

August 2008

Please note: This manual was current at the time of printing. To obtain the latest, most updated version, please contact Southworth's Customer Service Department or go to our website: www.SouthworthProducts.com, under E-Parts & Service you will find a complete list of current owner's manuals to print.

Contents

INTRODUCTION	4
SAFETY	4
Safety Considerations	5
INSTALLATION & OPERATING INSTRUCTIONS	5
Positioning the Lift.....	5
Hydraulic Connections	5
Electrical Connections.....	6
Testing.....	6
Completing Installation.....	6
MAINTENANCE.....	6
Hazards.....	6
Routine periodic maintenance.....	7
Maintenance for machines with high cycle pkg.....	7
Maintenance for units with air motors	8
TROUBLESHOOTING.....	9
If the machine will not raise.....	9
The machine elevates but fails to hold a load	10
The machine fails to lower	10
ORDERING REPLACEMENT PARTS.....	11
RETURN MATERIALS AUTHORIZATION (RMA) Procedures.....	32
WARRANTY	33

List of Figures

Fig. 1. Units with Air Motors.....	8
Part I: Single Acting Tilter	
Fig. 2. Electrical connections for single phase AC.....	13
Fig. 3. Electrical connections for three phase AC.....	14
Fig. 4. Electrical connections for single phase AC.....	15
Fig. 5. Electrical connections for three phase AC.....	16
Part II: Double Acting Tilter	
Fig. 6. Electrical connections for single phase AC.....	18
Fig. 7. Electrical connections for three phase AC.....	19
Fig. 8. Hydraulic connections for single phase AC	20
Fig. 9. Hydraulic connections for three phase AC	21
Part III: Upender	
Fig. 10. Electrical connections for single phase AC.....	23
Fig. 11. Electrical connections for three phase AC.....	24
Fig. 12. Hydraulic schematic for single phase AC	25
Fig. 13. Hydraulic schematic for three phase AC	26
Part IV: Lift / Tilt	
Fig. 14. Electrical connections for single phase AC.....	28
Fig. 15. Electrical connections for three phase AC.....	29
Fig. 16. Hydraulic schematic for single phase AC	30
Fig. 17. Hydraulic schematic for three phase AC	31

INTRODUCTION

This manual contains information to acquaint you with the safe and proper installation, use and up-keep of the machine. You should ensure that this manual is available to personnel working with the machine and require its use by these personnel.

In the interest of safety, please read this entire manual carefully and be familiar with its contents before you install, use or service the machine. If you have any questions about any instructions in this manual, please contact your dealer or Southworth Products Corp.

Southworth's product warranty is provided in the back of this manual. This instruction manual is not intended to be or to create any other warranty, expressed or implied, including any implied warranty of merchantability or fitness for a particular purpose, all of which are hereby expressly excluded.

As set forth more specifically in the product warranty, Southworth's obligation under that warranty is limited to the repair or replacement of defective components, which shall be the buyer's sole remedy. Southworth shall not be liable for any loss, injury or damage to persons or property, nor for any direct, indirect or consequential damage of any kind resulting from the lift table.

SAFETY

The safety of all persons operating, maintaining, repairing or in the vicinity of the machine is of paramount concern to Southworth. This is a powerful machine with moving parts and is capable of causing personal injury if proper precautions are not taken. Therefore, throughout this manual, Southworth has identified certain hazards that may occur in the use of this machine and provided appropriate instruction or precautions that should be taken to avoid these hazards. In some cases, Southworth has also pointed out the consequences that may occur if Southworth's instructions or precautions are not followed. Southworth uses the following system of identifying the severity of the hazards associated with its products

SIGNAL WORD

The word or words that designates a degree or level of hazard seriousness. The signal words for product safety signs are "**DANGER, WARNING and CAUTION.**"

" DANGER "	Immediate hazard which will result in severe personal injury or death.
" WARNING "	Hazardous or unsafe practice which could result in severe personal injury or death.
" CAUTION "	Hazardous or unsafe practice that could result in minor personal injury or property damage.

Please read and follow the instructions in this manual, including all safety instructions and precautions carefully and completely.

SAFETY CONSIDERATIONS

Southworth Hydraulic Lift tables are designed and manufactured to meet the safety requirements of the *ANSI Standard MH29.2-2000, Industrial Tilters*.

Southworth Hydraulic Lift Tables are equipped with a pressure safety relief valve so overloading will not “burst” the air bag.

Southworth Hydraulic Lift Tables have a safety orifice speed control. This regulates the down speed. Should an air line rupture, the unit will descend at about the normal rate. This orifice is not adjustable.

All Southworth Hydraulic Lift Tables can be fitted (optional) with industrial, high quality dampers to provide smooth movement even when loads are abruptly introduced to the platform.

Southworth units are also equipped with safe, reliable Firestone air spring actuators rather than vinyl air bags.

All Southworth models are designed with a generous safety factor of three to one.

INSTALLATION & OPERATING INSTRUCTIONS

1. Before you start to install the machine, check for local codes and ordinances, which may apply in your area. It is your responsibility to obtain any necessary permits.

2. Read all of these installation instructions carefully. Be sure to read and understand all of the warnings!

3. If the hydraulic power unit will be mounted away from the machine, the power unit should be sheltered from the weather. It should be mounted within 30 feet of the machine to minimize the pressure drop in the hydraulic system. Be sure the hydraulic lines have been installed properly.

WARNING!

Protect the hydraulic power unit from rain or moisture. If the electrical parts in the power unit get wet, workers may be hurt by electrical shock or the electrical parts may fail.

WARNING!

The electric motor in the lift can create sparks. Do not install the hydraulic power unit in an area where flammable gases may be present.

POSITIONING THE LIFT

1. Remove the shipping material and unskid the machine.

2. Move the machine into position, supporting the base frame of the machine. Mount the machine on a firm level surface, if necessary, insert shims to level the machine. Install lag bolts to hold the machine in place. Make sure to shim or grout under the base frame to prevent any flexing.

WARNING!

If the machine is mounted on an unstable surface, it may tip over when in use. You may be hurt, and the machine or the load may be damaged.

HYDRAULIC CONNECTIONS

1. Mount the hydraulic power unit in a desired place.

2. Connect the hydraulic line between the hydraulic power unit and the machine.

WARNING!

Be sure that the hydraulic line will not be pinched by the machine during operation. If you allow the line to be pinched, the machine may not work properly. A hose may break, the machine may drop suddenly, and someone may be hurt.

CAUTION!

It is very important to keep the hydraulic oil free from dirt, dust, metal chips, water and other contamination. Most of the problems with hydraulic systems are caused by contamination of the oil.

ELECTRICAL CONNECTIONS

DANGER!

The lift may use a power supply of up to 460 Volt AC. This voltage can kill you. Do not work with the electrical parts unless you are a qualified electrician.

1. A machine with a 115 Volt power unit needs to have a designated outlet and breaker of at least 20 AMP.

2. A machine designed for three phase AC, you must be sure the pump and motor is turning in the right direction. The machine should start to move quickly when you press the up or down button. If the machine does not move in 2 or 3 seconds, do not try to operate the machine! Exchange any two of the three phase leads. If this does not correct the problem, please contact Southworth 's Customer Service Department.

TESTING

1. Check the level of the hydraulic oil. With the machine in the lowered position the tank should be full, add oil if necessary.

2. Clear the area around the machine. Remove any loose wires, lumber or other material that might get in the way of the machine as it is in use.

3. Operate the machine through its full range of travel. The machine should rise smoothly with a quiet humming sound and lower smoothly and quietly. Raise and lower the lift a few times to check the clearances around the lift table.

WARNING!

As the machine moves, "pinch points" are created. If you are standing too close to the machine when it is moving, your arm or leg may be caught in the moving parts and you may be hurt. Stay away from the pinch points when the lift is moving.

COMPLETING INSTALLATION

1. Test the machine with the rated load. If the machine does not move and you hear a loud squealing noise, this means the pressure relief valve is operating. Contact Southworth for instructions.

WARNING!

Do not continue to use the machine if this happens. The pump will overheat very quickly and may be permanently damaged. Do not try to adjust the relief valve. You may overwork the machine. This can cause the machine to fail suddenly and you may be hurt.

MAINTENANCE

All service should be done by qualified personnel. Qualified personnel should be able to read and understand wiring and hydraulic diagrams. They should be able to troubleshoot live electrical circuits safely and in accordance with accepted practice.

FOR SAFETY'S SAKE, if in doubt, please contact your dealer of Southworth Products Corporation Customer Service Department at (207)878-0700 or (800)743-1000.

Before servicing the lift, read and understand this entire section and the section entitled "Operating Instructions."

HAZARDS

There are several hazards you should be aware of as you service the lift:

Before working on the machine be sure to insert any and all maintenance devices.

DANGER!

The machine may use a power supply of up to 575 Volts. This voltage can kill you. Do not work with the electrical parts unless you are a qualified electrician.

WARNING!

As the machine moves, “pinch points” are created. Keep hands, feet and loose clothing away from these pinch points. If your arms, hands or your clothing is caught, you may be hurt.

WARNING!

Do not change the setting on the relief valve in the pump. If you do, this may damage the machine and you may be hurt. The relief valve has been included for the protection of all of the workers who use the machine.

WARNING!

Before working on the machine, be sure to release pressure on the hydraulic system.

CAUTION!

The warning labels on the machine are there for the safety of the operator. If the labels are worn or missing, replace them.

ROUTINE PERIODIC MAINTENANCE**Every month:**

1. Visually inspect the center pivot bushing and pins, cylinder clevis pins and bushings. Apply oil or WD-40 to all parts listed above.

Note: Although the bearings are “lifetime lubricated” their performance may be extended by additional periodic lubrication (WD-40).

2. Check the level and appearance of the hydraulic fluid. With the machine in the lowered position, there should be about $\frac{3}{4}$ of an inch of air space in the tank or with the machine fully elevated, there should be about $\frac{3}{4}$ of an inch of oil left in the tank. Use a dipstick to check the oil level and add oil if necessary. Change the oil if it has darkened from its original color, turned milky white or if it feels gritty or sticky.

CAUTION!

It is important to use hydraulic fluid with the correct grade and properties. The hydraulic fluid the machine is provided with is Texaco Rando HD-32

Every six months:

1. Check all of the hydraulic fittings and hoses and repair the connections if necessary. Occasionally, the fittings can be worked loose by vibrations from the machine.

WARNING!

If a hydraulic fitting becomes loose or if a hydraulic hose breaks, the hydraulic fluid will escape from the system under pressure. If the machine is elevated when this happens, it will drop very quickly. Someone may be hurt or the product or the machine may be damaged.

2. Remove the down valve from the pump and the solenoid. Disassemble and clean using compressed air. Reassemble and reinstall.

3. Drain all of the hydraulic fluid from the tank and cylinders and discard it.

4. Remove the suction filter from the tank. Clean by using compressed air. Reinstall and tighten all fittings.

5. Refill the tank with new hydraulic fluid.

Maintenance for machines with high cycle package:

1. Every 10,000 cycles or every month, visually inspect the entire lift. Replace all worn or broken parts. Change the hydraulic fluid. Lubricate all pivot points and clean the roller tracks.

2. Every 30,000 cycles or every three months, visually inspect the entire lift. Check the motor starter contacts and limit switch. Clean and lubricate all pivot points. Replace all worn or broken parts. Replace all hydraulic filters and change the hydraulic fluid.

Maintenance for units with Air Motors:

On this type of unit, the air motor is used to power the hydraulic pump (see figure 1). When the lift is raised, a valve sends compressed air to the air motor. The air motor powers the pump and provides hydraulic power for the unit. When the lift is lowered, an air operated down valve allows the hydraulic fluid to escape from the cylinders.

The vanes in the rotary type air motor take up their own wear and will last 5,000 to 15,000 hours of operation. (The actual service lift depends on the operating speed, method of oiling, operating pressure, and the precautions taken in maintaining the machine.) The type of shaft seal used will not withstand pressures of more than 100 psi.

An automatic airline lubricator must be installed in the airline just ahead of the motor. (The filter, regulator, and lubricator are not supplied by Southworth.) The lubricator must be adjusted to feed on drop of oil for every 50 to 75 cfm of air going through the motor. This lubrication is necessary to reduce friction on all internal moving parts and to prevent rust.

The starting torque of the air motor is greater than the running torque. This could vary depending on the position at which the vanes stop in relation to the air intake port. It is advisable to use a pressure regulator or a simple shut off valve to obtain the desired power, speed, and torque; and to conserve air.

CAUTION!

Do not allow the air motor to “run free” at high speed with no load. This can cause buildup of excessive heat and loss of internal clearances and can damage the motor quickly.

If the motor is sluggish or inefficient, try flushing it with solvent. To flush a motor, disconnect the airline and muffler. Add several teaspoons of solvent directly into the motor. (Southworth recommends the following solvents for this purpose: Gast Flushing Solvent AH255, Dem Kote 2X726 and Loctite Safety Solvent.) Rotate the shafts by hand in both directions for a few minutes. Reconnect the airline and gradually increase the air pressure and flow until there is no trace of the solvent in the exhaust air. Re-lubricate the motor with a squirt of oil in the chamber.

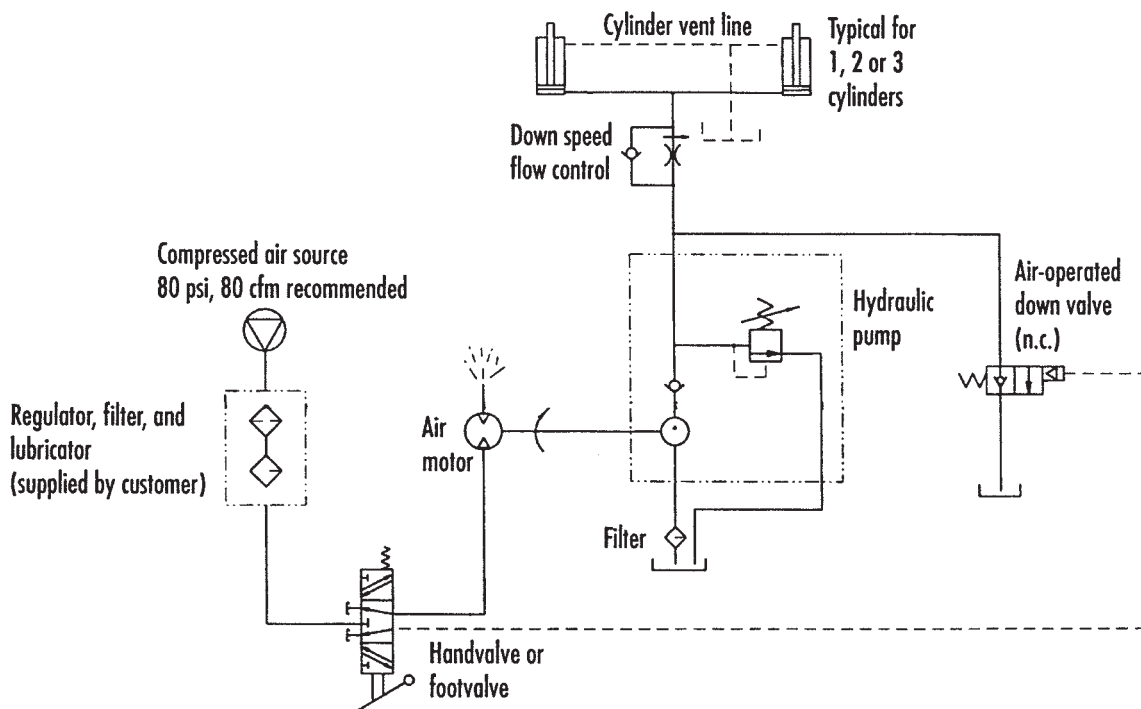

Figure 1. Units with Air Motors

TROUBLESHOOTING

All service should be done by qualified personnel. Qualified personnel should be able to read and understand wiring and hydraulic diagrams. They should be able to troubleshoot live electrical circuits safely and in accordance with accepted practice.

FOR SAFETY'S SAKE, if in doubt, please contact your dealer or Southworth Products Corporation Customer Service Department at (207)878-0700 or (800)743-1000.

Before servicing the lift, read and understand this entire section and the section entitled "Operating Instructions." Before working on the machine, be sure to insert any and all maintenance devises. Failure to do so may result in damage to the machine and severe personal injury!

If the machine will not raise:

CAUTION!

Do not continue to hold the "up" button for more than 2 or 3 seconds. You may damage the pump.

1. The machine may be overloaded. Check the actual weight of the load. The rated capacity of the machine is shown on the table skirt.

WARNING!

Do not change the setting on the relief valve in the pump. If you do, this may damage the machine and you may be hurt. The relief valve has been included for the protection of all of the workers who use the machine.

2. If the motor is not running, check the main disconnect switch, the fuse(s) and the wiring to the motor.

Using an external lifting mechanism, such as a crane or a forklift, raise the machine and insert any and all maintenance devises.

3. Check the level of the hydraulic fluid. With the machine in the lowered position there should be about $\frac{3}{4}$ of an inch of air space in the tank or with the

machine fully elevated, there should be about $\frac{3}{4}$ of an inch of oil left in the tank. Use a dipstick to check the oil level, add oil if necessary.

4. If the machine rises but does not rise completely, the machine may have an optional up limit switch. This switch may just need to be readjusted.

WARNING!

Do not disconnect the up limit switch. Instead, loosen the adjusting screw and change the position of the arm. If you do disconnect the switch, when the lift platform moves up, it may not stop at the correct spot, the machine may be damaged and people may be hurt.

5. On a machine equipped with a three-phase motor, the motor may be running backwards. If the motor has been wired correctly, the machine should start to move in 2 or 3 seconds after you hit the "up" button. If the machine does not move, try reversing any two power leads.

6. On a machine equipped with a three-phase motor, the motor may be "single phasing." When this happens, the motor hums but does not turn. If this is the case, one lead of the three-phase line has been interrupted. Check the motor wiring and line fuses.

7. The power supply to the motor could be too low. Check the voltage at the motor when it is under a full load. The supply voltage should be within 10% +/- of the rating.

8. If the machine is equipped with an external power unit, the tank vent may be plugged. You must remove the solid plug from the tank and insert the vented plug. The vent line must also be clean.

9. The suction filter in the tank may be clogged. Clean the filter as described in the maintenance section.

OPERATING AND MAINTENANCE MANUAL

10. A vacuum leak may be allowing air into the suction line. This will cause the pump to cavitate (loss of suction). Check all fittings in the suction line and replace or repair if necessary.

CAUTION!

If cavitation is allowed to continue, the pump will be damaged and will need to be replaced.

11. For the machine to elevate, the down valve must be de-energized and fully closed. Check the wiring for a down valve to the control box. The down valve must be clean and free to operate.

12. If the pump or the motor has been changed for any reason, the coupling may not have been installed.

The machine elevates but fails to hold the load:

Before working on the machine, be sure to insert any and all maintenance devices. Failure to do so may result in damage to the machine and severe personal injury!

1. The check valve may be leaking. Dirt on the valve seat will prevent the valve from closing fully. The valve seat is mounted in the pump. Remove the check valve cap and inspect the valve for dirt or metal that may be preventing it from closing. You may be able to restore the seal by light rapping the check valve ball into the seat using a ¼ inch diameter brass rod and a small hammer.

2. The down valve may be sticking. While the lift is holding a load, the down valve needs to be fully closed. The valve must always be clean and free to operate. To check this, remove the solenoid from the valve, and then remove the valve from the pump. Look for contamination that could block the valve action. Clean the valve plunger with kerosene and blow clean with compressed air. The expansion nut that holds the solenoid on the valve should only be finger tight!

3. The cylinder(s) may be leaking. Look for oil on the cylinder rod(s) and on the floor. (This may also occur if the oil tank is overfilled.) If you find oil in

any of these places and the tank is not overfilled, then the cylinder(s) need to be either repacked or replaced.

The machine fails to lower:

Before working on the machine, be sure to insert and all maintenance devices. Failure to do so may result in damage to the machine and severe personal injury!

1. The down valve may be de-energized. When the machine is lowering, the down valve needs to be fully open. Check the solenoid with a voltmeter. The valve must also be clean and free to operate. To check this, remove the solenoid from the valve and remove the valve from the pump. Look for contamination that could block the valve action. Clean the valve plunger with kerosene and blow clean with compressed air. The expansion nut that holds the solenoid on the valve should only be finger tight!

2. The flow control may need to be adjusted. The flow control must be partially open to allow the oil to return to the tank from the cylinder(s).

If the steps listed above do not solve the problem, please call the Customer Service Department at Southworth Products Corp. (207)878-0700 or (800)743-1000.

ORDERING REPLACEMENT PARTS

Southworth has carefully chosen the components in your unit to be the best available for the purpose. Replacement parts should be identical to the original equipment. **Southworth will not be responsible for equipment failures resulting from the use of incorrect replacement parts or from unauthorized modifications to the machine.**

Southworth can supply all replacement parts for your Southworth lift. We have identified key replacement parts for your lift. With your order, please include the model number and the serial number of the unit. You will find these numbers on the name plate.

To order replacement parts, please call the Parts Department at (207) 878-0700. Parts are shipped subject to the following terms:

- FOB factory.
- Returns only with the approval of our parts department.
- Payment net 30 days (except parts covered by warranty).
- Freight collect (except parts covered by warranty).

Parts replaced under warranty are on a "charge-credit" basis. We will invoice you when we ship the replacement part, then credit you when you return the worn or damaged part.

Parts Department
Southworth Products Corp
P.O. Box 1380
Portland, ME 04104-1380
Telephone: (207) 878-0700
FAX: (207) 797-4734
repairparts@SouthworthProducts.com

FIGURES & DIAGRAMS

PART I: SINGLE ACTING TILTER

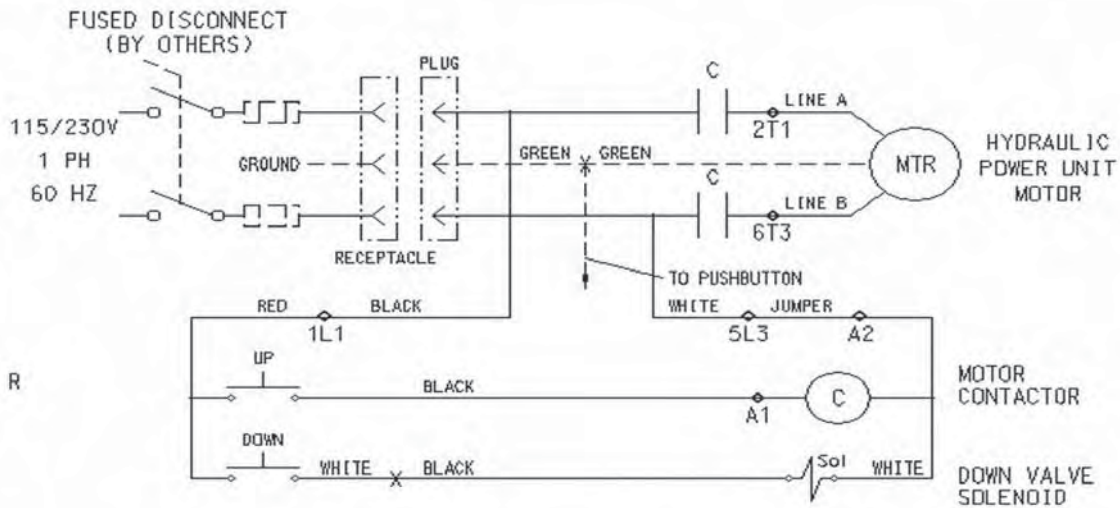

◇ - INDICATES TERMINAL ON THE CONTACTOR
 X - INDICATES WIRE CONNECTION IN THE ENCLOSURE

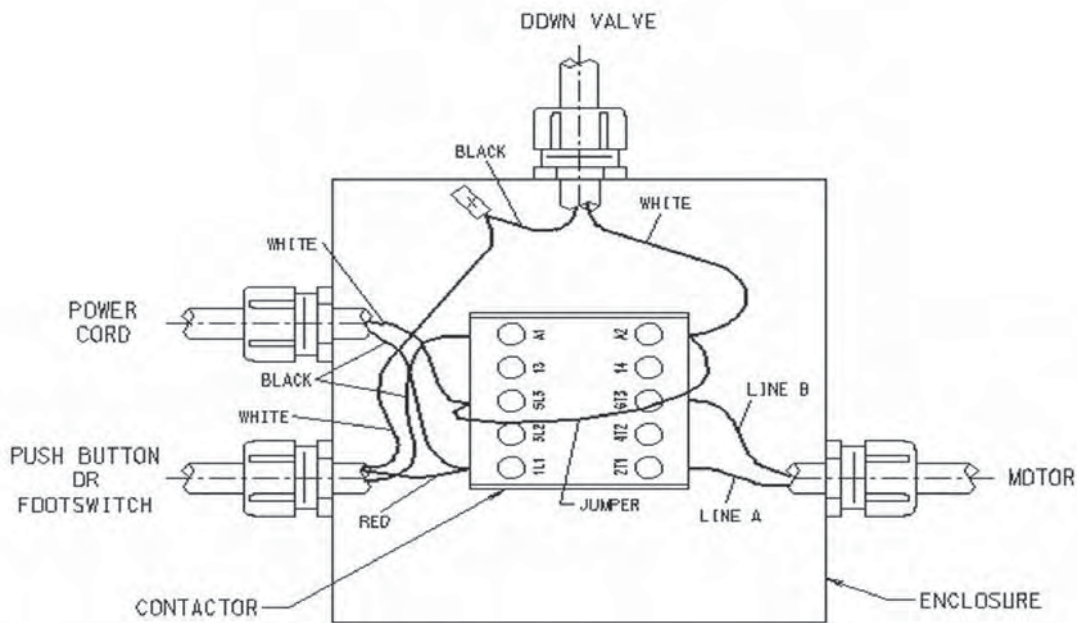

NOTE:
 - ENTRY LOCATIONS MAY DIFFER FROM THOSE SHOWN.
 - GROUND CONNECTIONS, ALTHOUGH NOT SHOWN, ARE REQUIRED.

- REFERENCE:
 B-3032834 STANDARD 1 PHASE
 B-3032835 WITH UP LIMIT
 B-3039865 WITH DOWN LIMIT
 B-3032836 WITH UP/DOWN LIMITS
 B-60012199 WITH INTERMEDIATE UP (N.O. HELD CLOSED)
 B-3060340 WITH UP PROXIMITY (N.C.)
 B-60003103 WITH UP PROXIMITY (N.O.)
 B-3034986 WITH TURNTABLE LIMIT
 B-3058888 WITH UP LIMIT & TURNTABLE LIMIT
 B-3031360 WITH MOTORSTARTER & O.L.
 B-3060468 WITH CONTROLS BY OTHERS & NO LIMITS
 B-3042174 WITH CONTROLS BY OTHERS & UP/DOWN LIMITS
 B-3062437 FOR MAINTAINED UP WITH UP LIMIT
 B-3060356 FOR MAINTAINED DOWN WITH DOWN LIMIT
 B-3045005 FOR MAINTAINED UP/DOWN (N.C. UP/DN LIMITS)
 B-60006251 FOR MAINTAINED UP/DOWN (N.O. UP / N.C. DN LIMITS)
 B-3038842 FOR DOUBLE-ACTING WITH UP/DN LIMITS

Figure 2. Electrical connections for Single Phase AC

OPERATING AND MAINTENANCE MANUAL

WIRING DIAGRAM

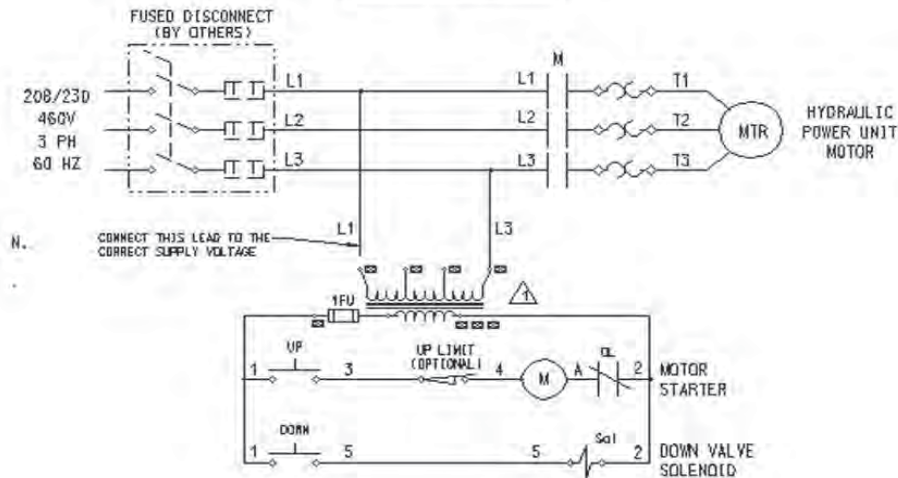

NOTE: UPPER TRAVEL LIMIT SWITCH IS OPTIONAL.
IF LIMIT SWITCH IS ABSENT, MOVE WIRE 4
IN PANEL FROM TERMINAL 4 TO TERMINAL 3
AND RENUMBER AS WIRE 3.

CONTROL PANEL

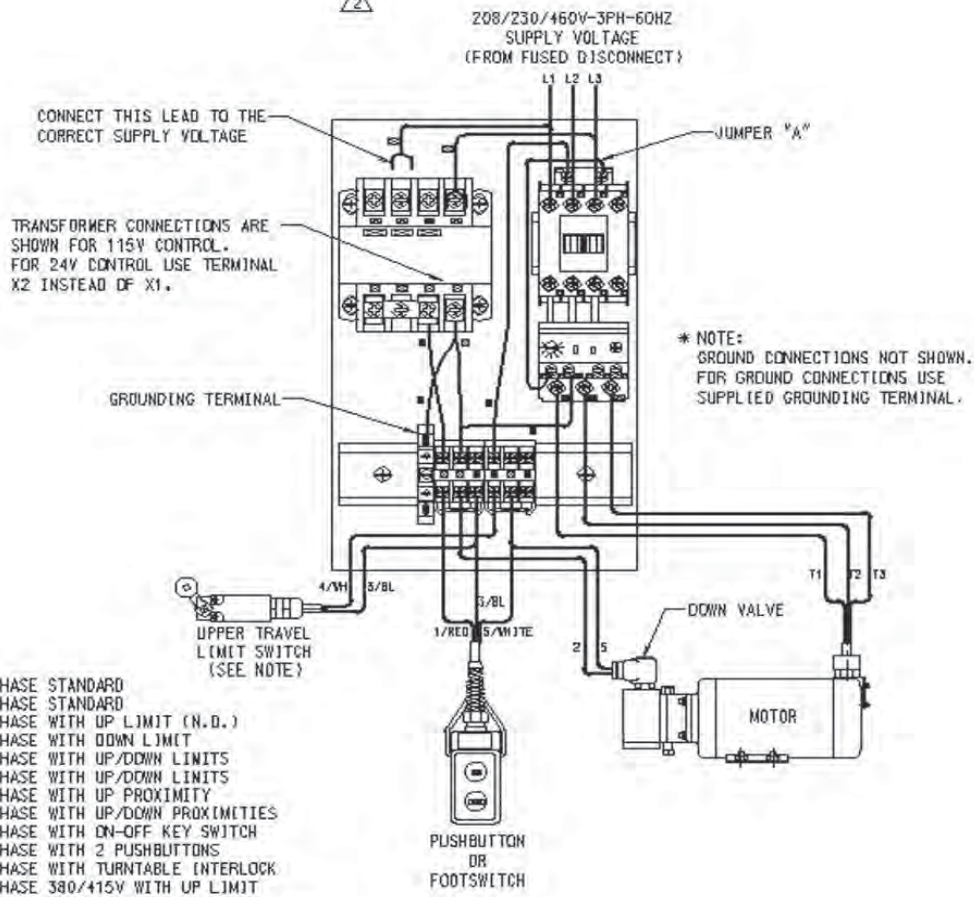

- REFERENCE:
- B-3040491 3 PHASE STANDARD
 - B-3040492 1 PHASE STANDARD
 - B-60011651 3 PHASE WITH UP LIMIT (N.D.)
 - B-3046011 3 PHASE WITH DOWN LIMIT
 - B-3041700 3 PHASE WITH UP/DOWN LIMITS
 - B-60098265 1 PHASE WITH UP/DOWN LIMITS
 - B-3052502 3 PHASE WITH UP PROXIMITY
 - B-60004901 3 PHASE WITH UP/DOWN PROXIMITIES
 - B-3043763 3 PHASE WITH ON-OFF KEY SWITCH
 - B-3035003 3 PHASE WITH 2 PUSHBUTTONS
 - A-3025366 3 PHASE WITH TURNTABLE INTERLOCK
 - B-3049491 3 PHASE 380/415V WITH UP LIMIT
 - B-3041740 3 PHASE 575/600V WITH UP LIMIT
 - B-3045661 3 PHASE 575/600V WITH UP/DOWN LIMITS
 - B-3003755 3 PHASE WITH PRIMARY FUSES
 - B-3041753 3 PHASE WITH FUSED DISCONNECT
 - B-3045046 3 PHASE WITH MAINTAINED UP
 - B-3045151 3 PHASE WITH MAINTAINED DOWN
 - B-3057068 3 PHASE WITH MAINTAINED UP/DOWN
 - C-3051986 3 PHASE WITH REMOTE RADIO CONTROL
 - B-3039373 3 PHASE WITH CONTROLS BY OTHERS & UP LIMIT
 - B-3051859 3 PHASE WITH CONTROLS BY OTHERS & UP/DOWN LIMITS

Figure 3. Electrical connections for Three Phase AC

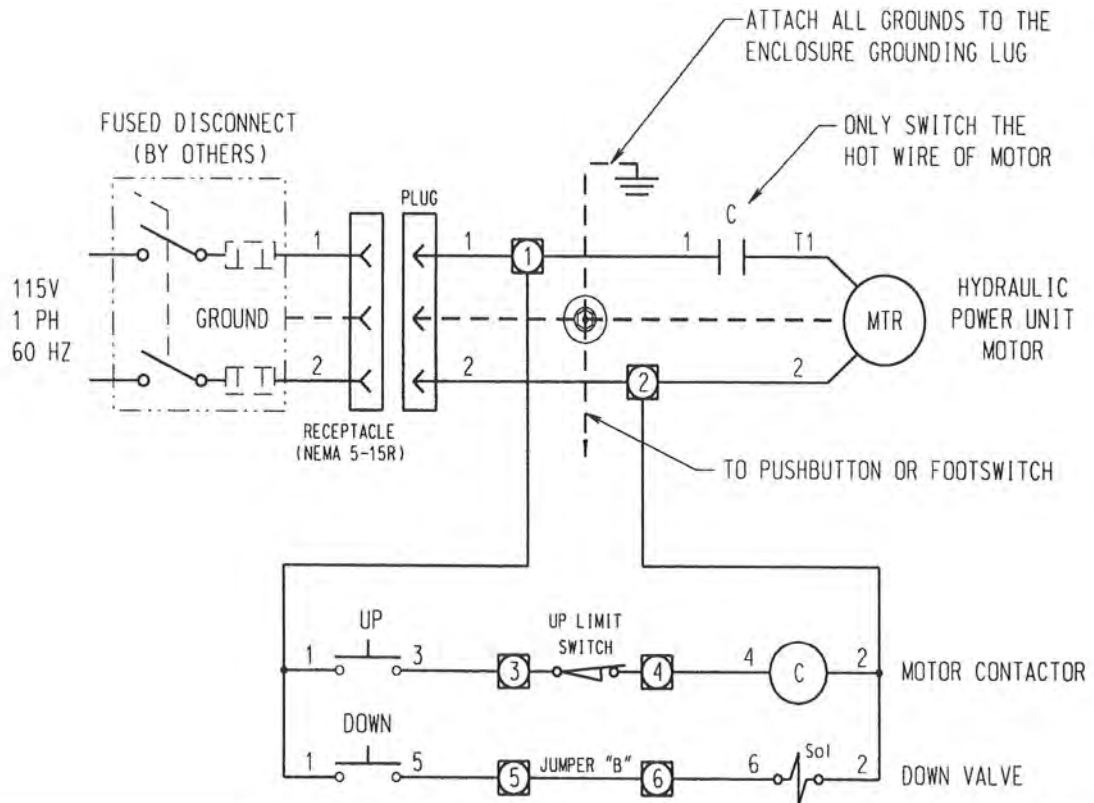

Figure 4. Electrical connections for Single Phase AC

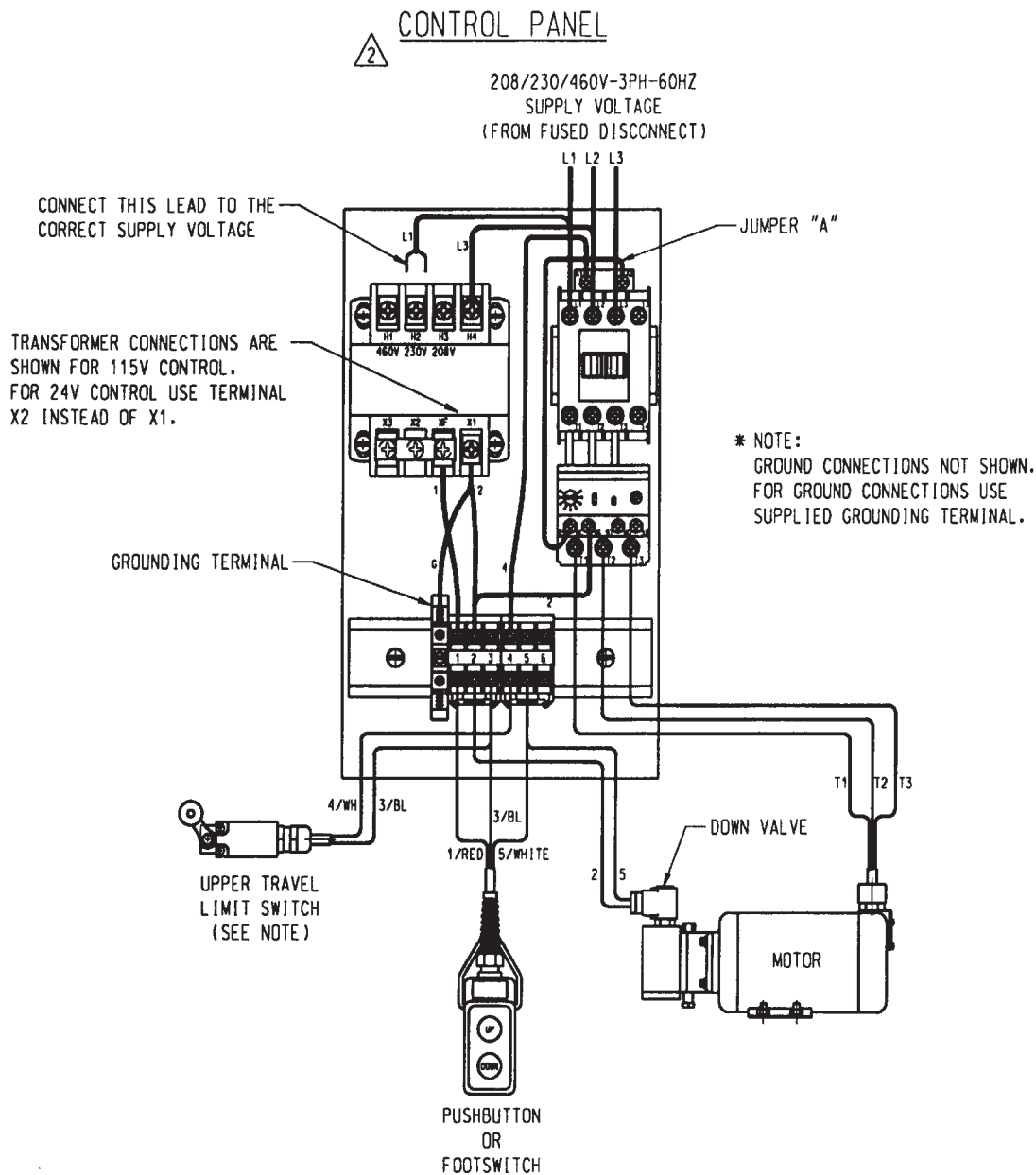

Figure 5. Electrical connections for Three Phase AC

FIGURES & DIAGRAMS

PART II: DOUBLE ACTING TILTER

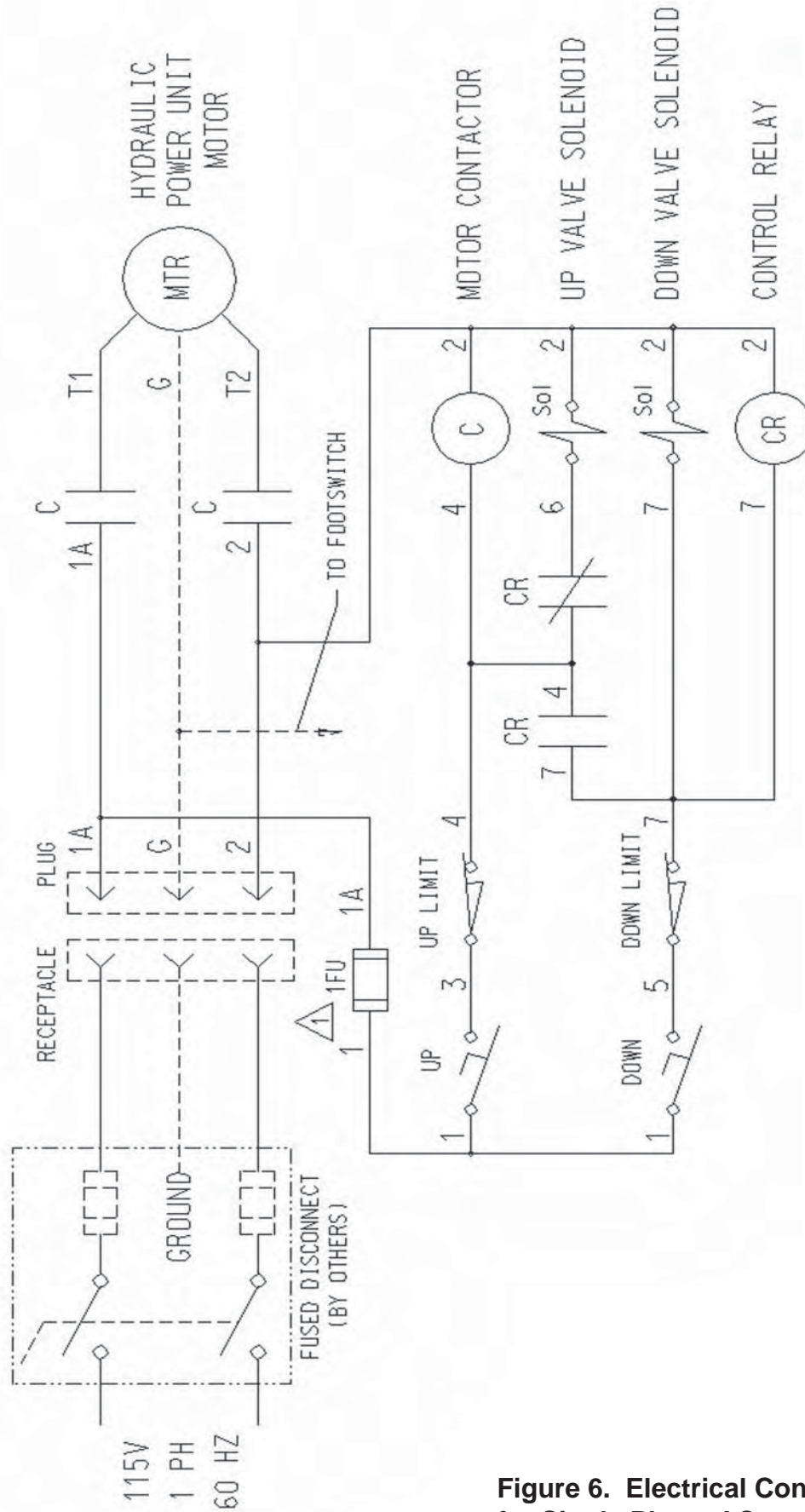
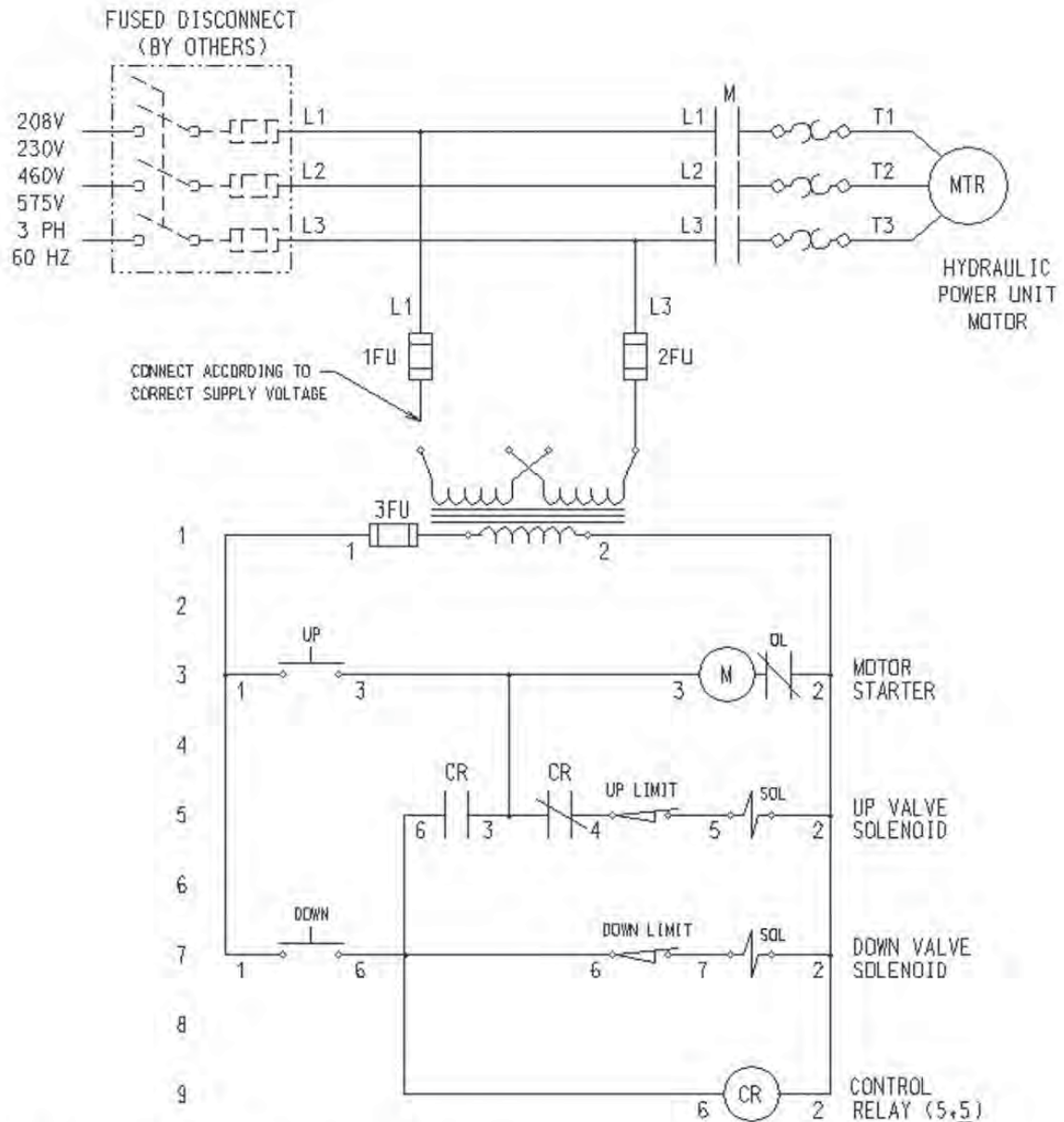

Figure 6. Electrical Connections for Single Phase AC



THE FOLLOWING WIRING DIAGRAMS CAN BE USED FOR MACHINES WITH NO COAST/NO DRIFT VALVING OR DOUBLE-ACTING CYLINDERS.

- SEE B-3046184 FOR 3 PHASE, RELAY, NO LIMITS
- SEE B-3048T01 FOR 3 PHASE, RELAY, UP LIMIT
- SEE B-3032618 FOR 3 PHASE, RELAY, UP/DOWN LIMITS
- SEE B-3062462 FOR 3 PHASE, RELAY, NO LIMITS, CONTROLS BY OTHERS
- SEE A-3046972 FOR 115-1-60, RELAY, UP/DOWN LIMITS
- SEE B-3048376 FOR 230-1-60, RELAY, UP/DOWN LIMITS
- SEE B-3058794 FOR 3 PHASE, NO RELAY, NO LIMITS
- SEE B-3027603 FOR 3 PHASE, NO RELAY, UP LIMIT
- SEE B-3035961 FOR 3 PHASE, NO RELAY, UP/DOWN LIMITS
- SEE A-3051890 FOR 115V, NO RELAY, NO LIMITS
- SEE A-3042T25 FOR 115V, NO RELAY, UP LIMIT
- SEE A-3038032 FOR 115V, NO RELAY, UP/DOWN LIMITS
- SEE B-3058T83 FOR 3 PHASE, MAINTAINED OPERATION
- SEE B-3046097 FOR 1 PHASE, MAINTAINED OPERATION
- SEE B-3059199 FOR 3 PHASE, DEADMAN OPERATION w/E-STOP
- SEE B-3062159 FOR 3 PHASE, RELAY, LIMITS, SLOW-UP VALVE
- SEE B-60014267 FOR 3 PHASE, RELAY, LIMITS, DUAL SERIES CONTROLS
- SEE B-60014299 FOR 3 PHASE, RELAY, LIMITS, KEY ON/OFF

Figure 7. Electrical Connections for Three Phase AC

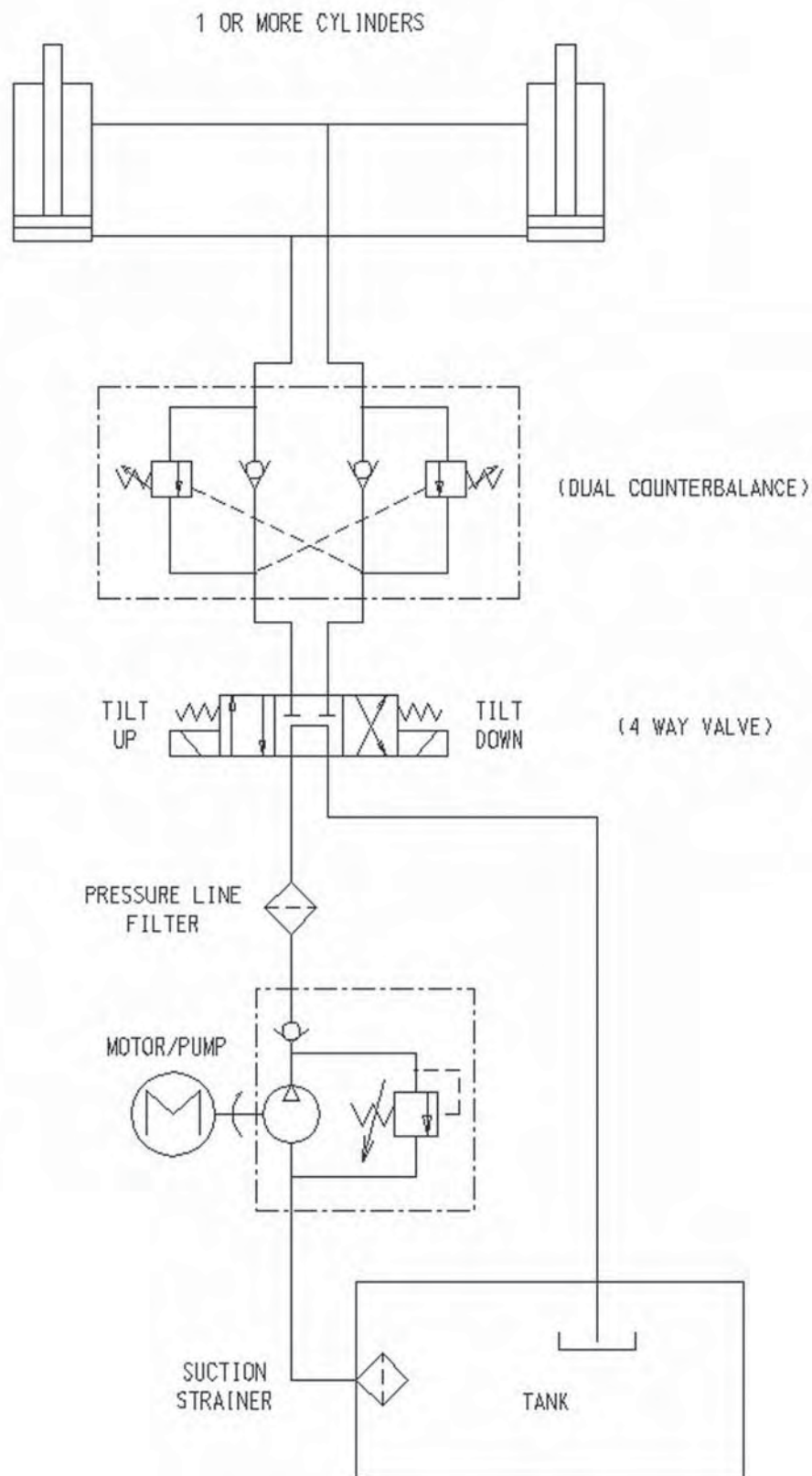

- REFERENCE:
- SEE B-3045535 FOR RETURN LINE FILTER
 - SEE B-3047820 FOR PRESSURE LINE FILTER
 - SEE B-3050024 FOR PRESSURE LINE FILTER & VELOCITY FUSES
 - SEE B-3055204 FOR PRESSURE LINE FILTER & (2) FLOW CONTROLS
 - SEE B-3060988 FOR RETURN LINE FILTER & (2) FLDW CONTROLS
 - SEE B-60003851 FOR RETURN LINE FILTER & (1) FLDW CONTROL
 - SEE B-3062158 FOR RETURN FILTER, FLOW CONTROLS, & SLOW-UP VALVE

Figure 8. Hydraulic Connections for Single Phase AC

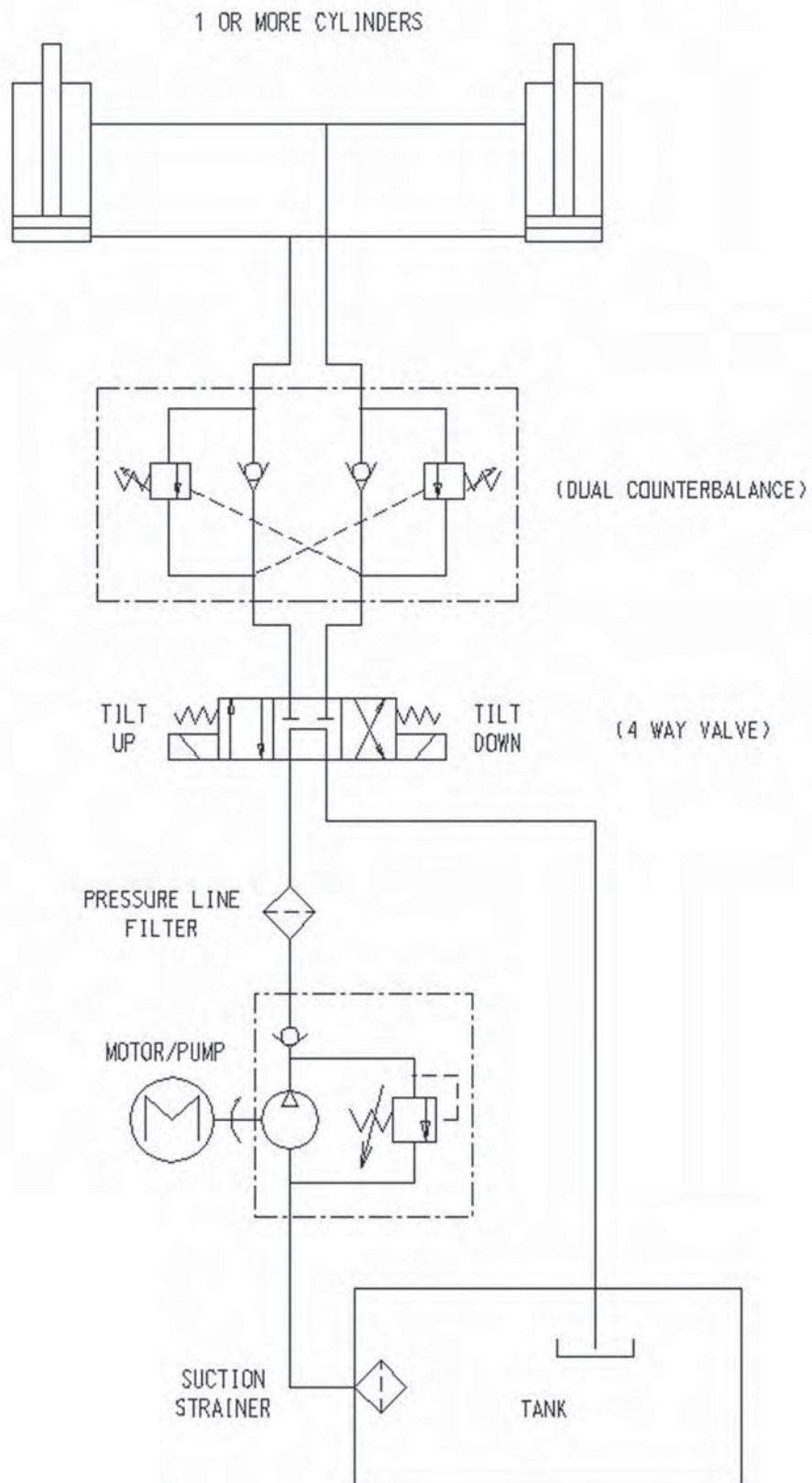

- REFERENCE:
 SEE B-3045535 FOR RETURN LINE FILTER
 SEE B-3047820 FOR PRESSURE LINE FILTER
 SEE B-3050024 FOR PRESSURE LINE FILTER & VELOCITY FUSES
 SEE B-3055204 FOR PRESSURE LINE FILTER & (2) FLOW CONTROLS
 SEE B-3060988 FOR RETURN LINE FILTER & (2) FLOW CONTROLS
 SEE B-60003851 FOR RETURN LINE FILTER & (1) FLOW CONTROL
 SEE B-3082158 FOR RETURN FILTER, FLOW CONTROLS, & SLOW-UP VALVE

Figure 9. Hydraulic connections for Three Phase AC

FIGURES & DIAGRAMS

PART III: UPENDER

OPERATING AND MAINTENANCE MANUAL

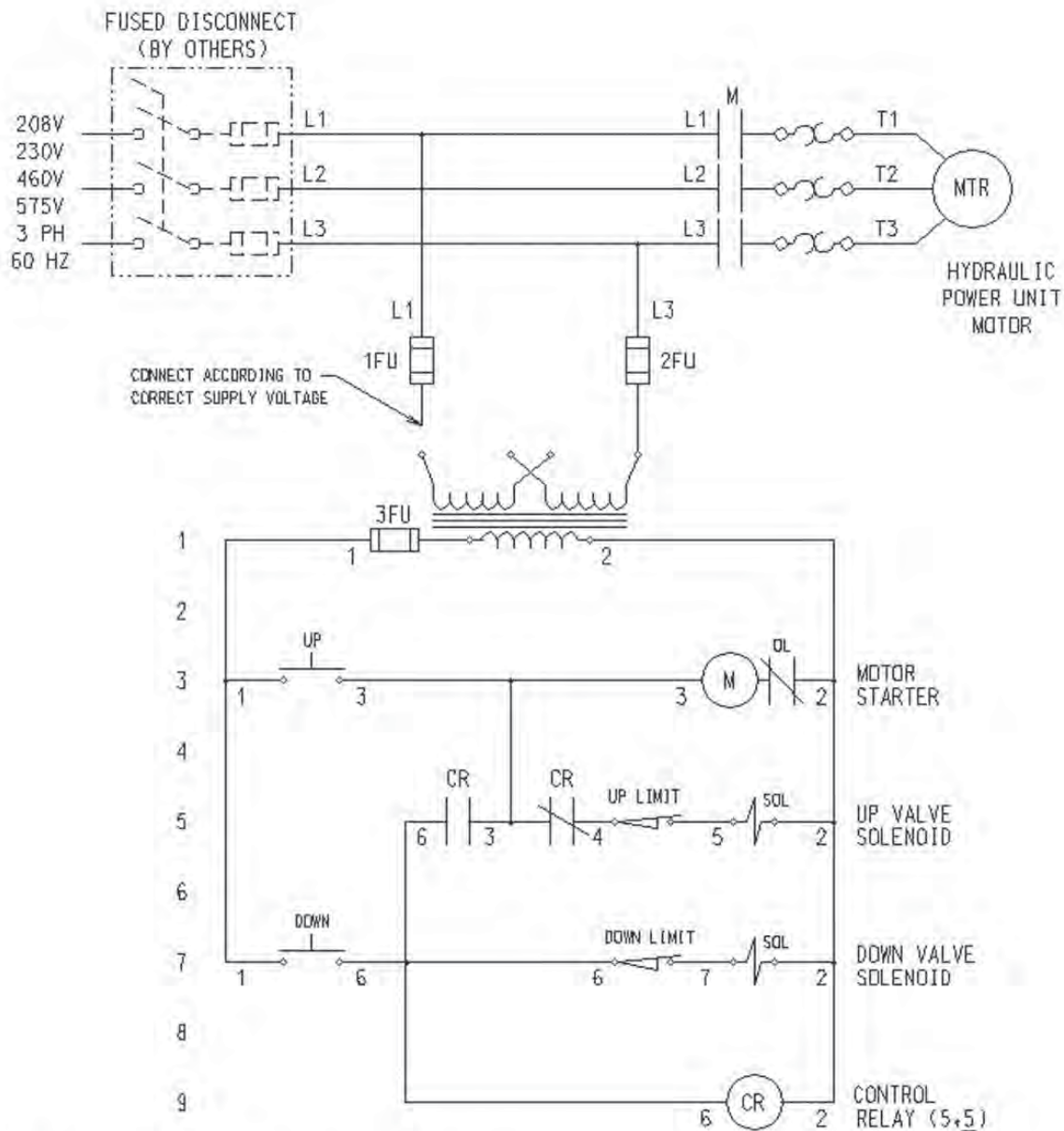

THE FOLLOWING WIRING DIAGRAMS CAN BE USED FOR MACHINES WITH NO COAST/NO DRIFT VALVING OR DOUBLE-ACTING CYLINDERS.

- SEE B-3046184 FOR 3 PHASE, RELAY, NO LIMITS
- SEE B-3048T01 FOR 3 PHASE, RELAY, UP LIMIT
- SEE B-3032618 FOR 3 PHASE, RELAY, UP/DOWN LIMITS
- SEE B-3062462 FOR 3 PHASE, RELAY, NO LIMITS, CONTROLS BY OTHERS
- SEE A-3046872 FOR 115-1-60, RELAY, UP/DOWN LIMITS
- SEE B-3048376 FOR 230-1-60, RELAY, UP/DOWN LIMITS
- SEE B-3058794 FOR 3 PHASE, NO RELAY, NO LIMITS
- SEE B-3027603 FOR 3 PHASE, NO RELAY, UP LIMIT
- SEE B-3035961 FOR 3 PHASE, NO RELAY, UP/DOWN LIMITS
- SEE A-3051890 FOR 115V, NO RELAY, NO LIMITS
- SEE A-3042T25 FOR 115V, NO RELAY, UP LIMIT
- SEE A-3038032 FOR 115V, NO RELAY, UP/DOWN LIMITS
- SEE B-3058T83 FOR 3 PHASE, MAINTAINED OPERATION
- SEE B-3046897 FOR 1 PHASE, MAINTAINED OPERATION
- SEE B-3059199 FOR 3 PHASE, DEADMAN OPERATION w/E-STOP
- SEE B-3062159 FOR 3 PHASE, RELAY, LIMITS, SLOW-UP VALVE
- SEE B-60014267 FOR 3 PHASE, RELAY, LIMITS, DUAL SERIES CONTROLS
- SEE B-60014299 FOR 3 PHASE, RELAY, LIMITS, KEY ON/OFF

Figure 11. Electrical connections for Three Phase AC

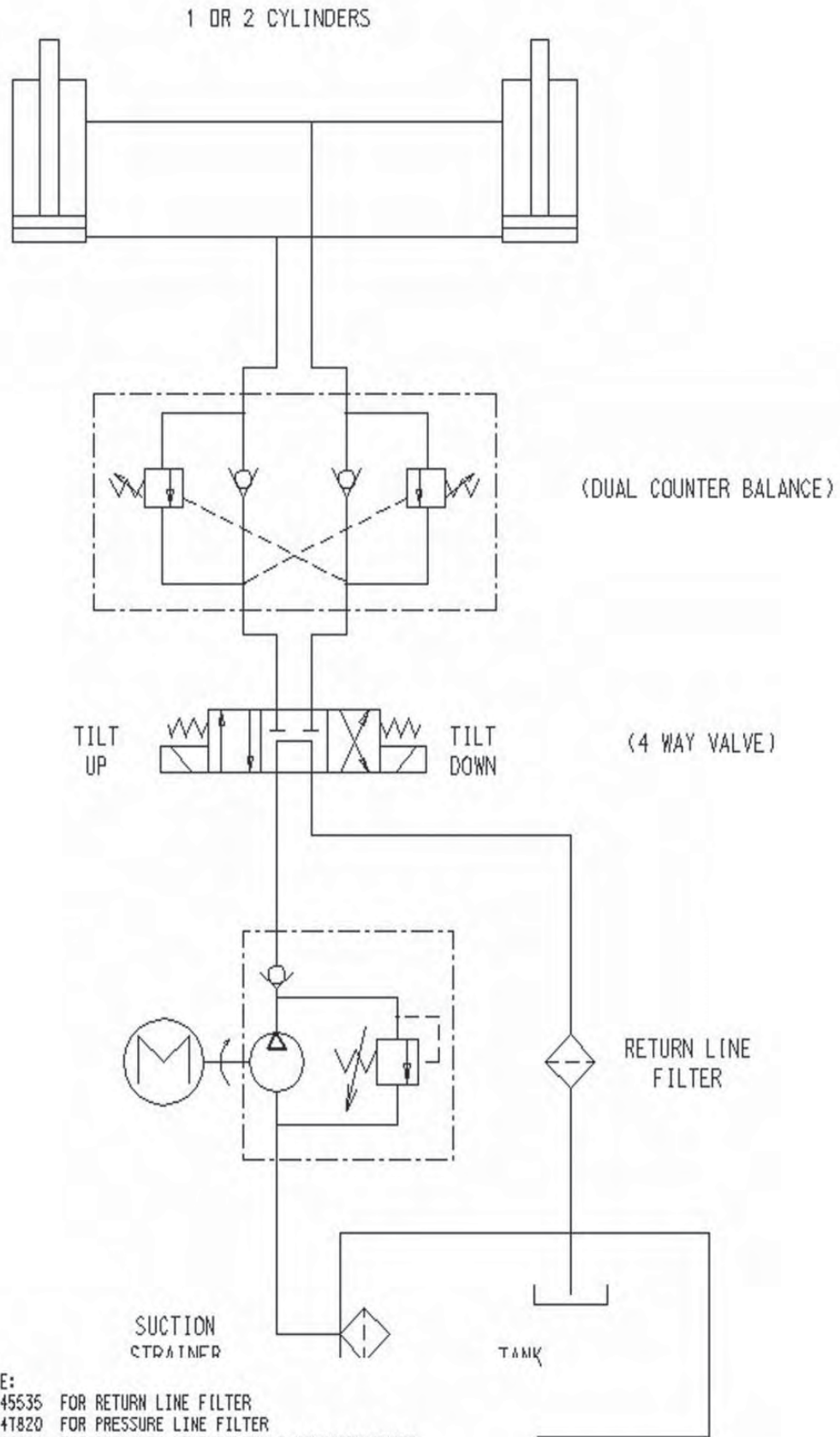

- REFERENCE:
- SEE B-3045535 FOR RETURN LINE FILTER
 - SEE B-3041820 FOR PRESSURE LINE FILTER
 - SEE B-3050024 FOR PRESSURE LINE FILTER & VELOCITY FUSES
 - SEE B-3055204 FOR PRESSURE LINE FILTER & (2) FLOW CONTROLS
 - SEE B-3060908 FOR RETURN LINE FILTER & (2) FLOW CONTROLS
 - SEE B-60003051 FOR RETURN LINE FILTER & (1) FLOW CONTROL
 - SEE B-3062150 FOR RETURN FILTER, FLOW CONTROLS, & SLOW-UP VALVE

Figure 12. Hydraulic schematic for Single Phase AC

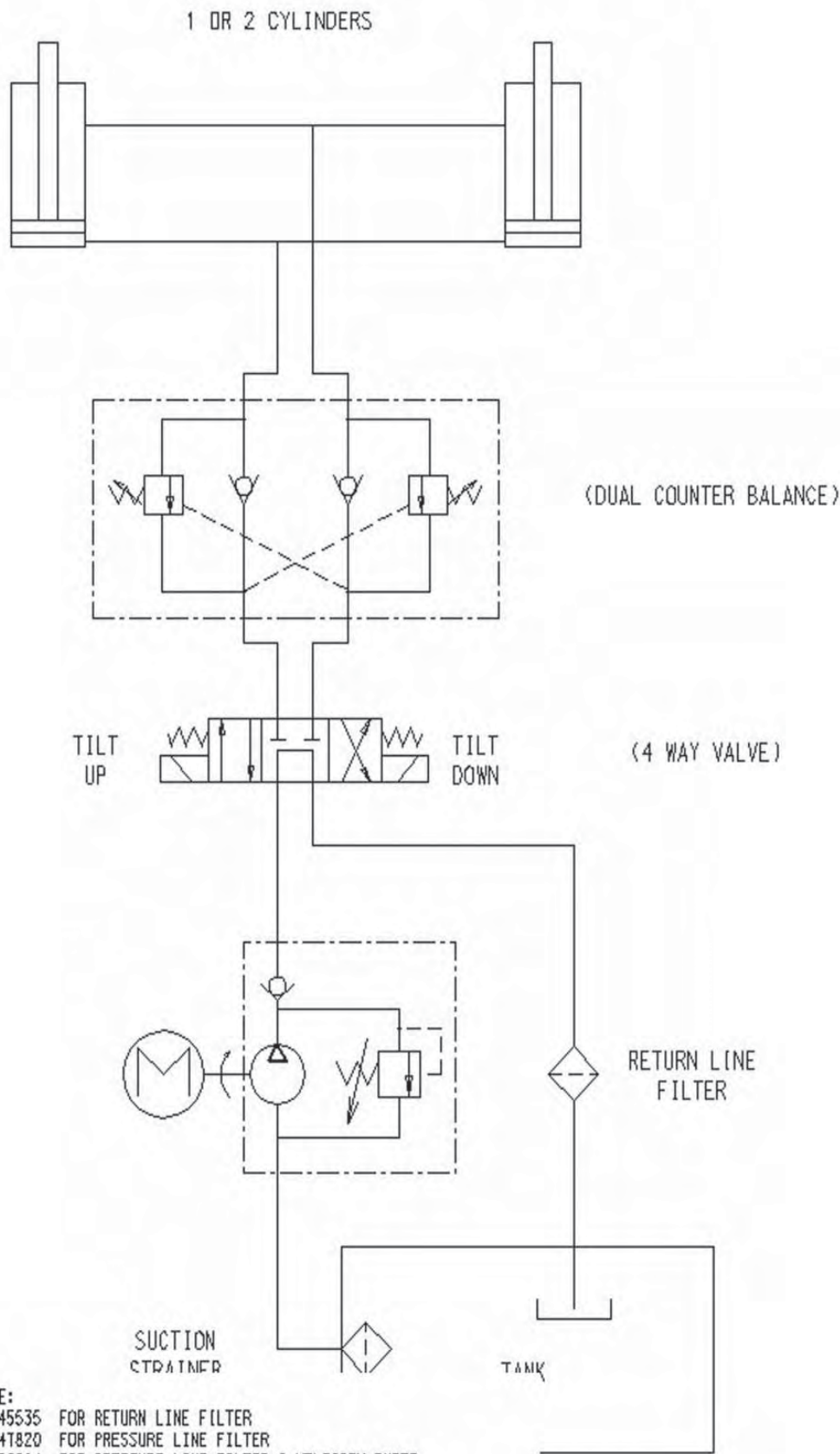

- REFERENCE:
- SEE B-3045535 FOR RETURN LINE FILTER
 - SEE B-3041820 FOR PRESSURE LINE FILTER
 - SEE B-3050024 FOR PRESSURE LINE FILTER & VELOCITY FUSES
 - SEE B-3055204 FOR PRESSURE LINE FILTER & (2) FLOW CONTROLS
 - SEE B-3060908 FOR RETURN LINE FILTER & (2) FLOW CONTROLS
 - SEE B-60003051 FOR RETURN LINE FILTER & (1) FLOW CONTROL
 - SEE B-3062150 FOR RETURN FILTER, FLOW CONTROLS, & SLOW-UP VALVE

Figure 13. Hydraulic Schematic for Three Phase AC

FIGURES & DIAGRAMS

PART IV: LIFT / TILT

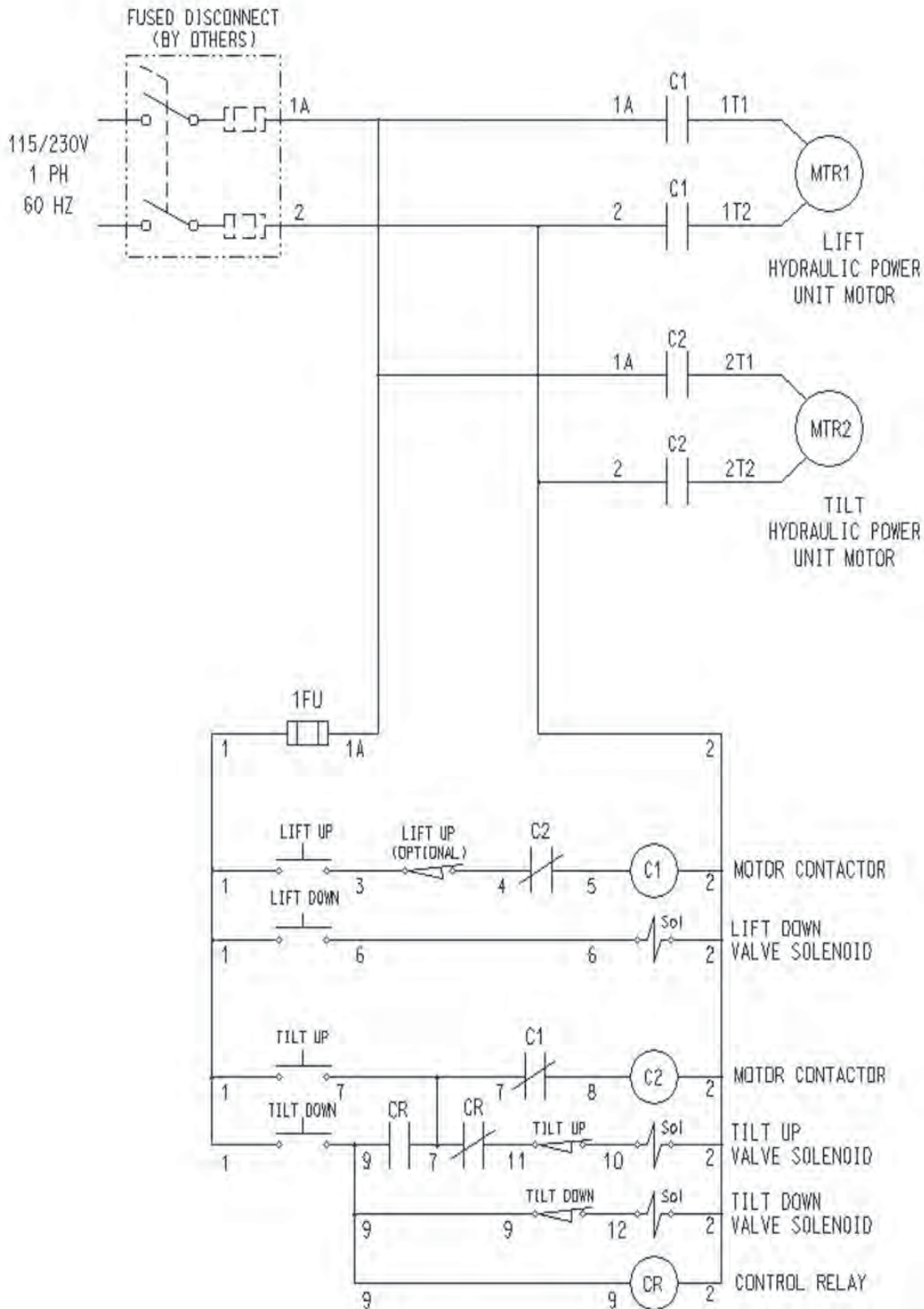

NOTE:

- 1.) THIS DIAGRAM MAY ALSO BE USED WHEN FOOTSWITCHES ARE USED IN PLACE OF PUSHBUTTONS.
- 2.) IF UP LIMIT SWITCH (OPTIONAL) IS ABSENT RUN WIRE #3 TO THE AUXILIARY CONTACT ON TILT MOTOR CONTACTOR.

Figure 14. Electrical Connections for Single Phase AC

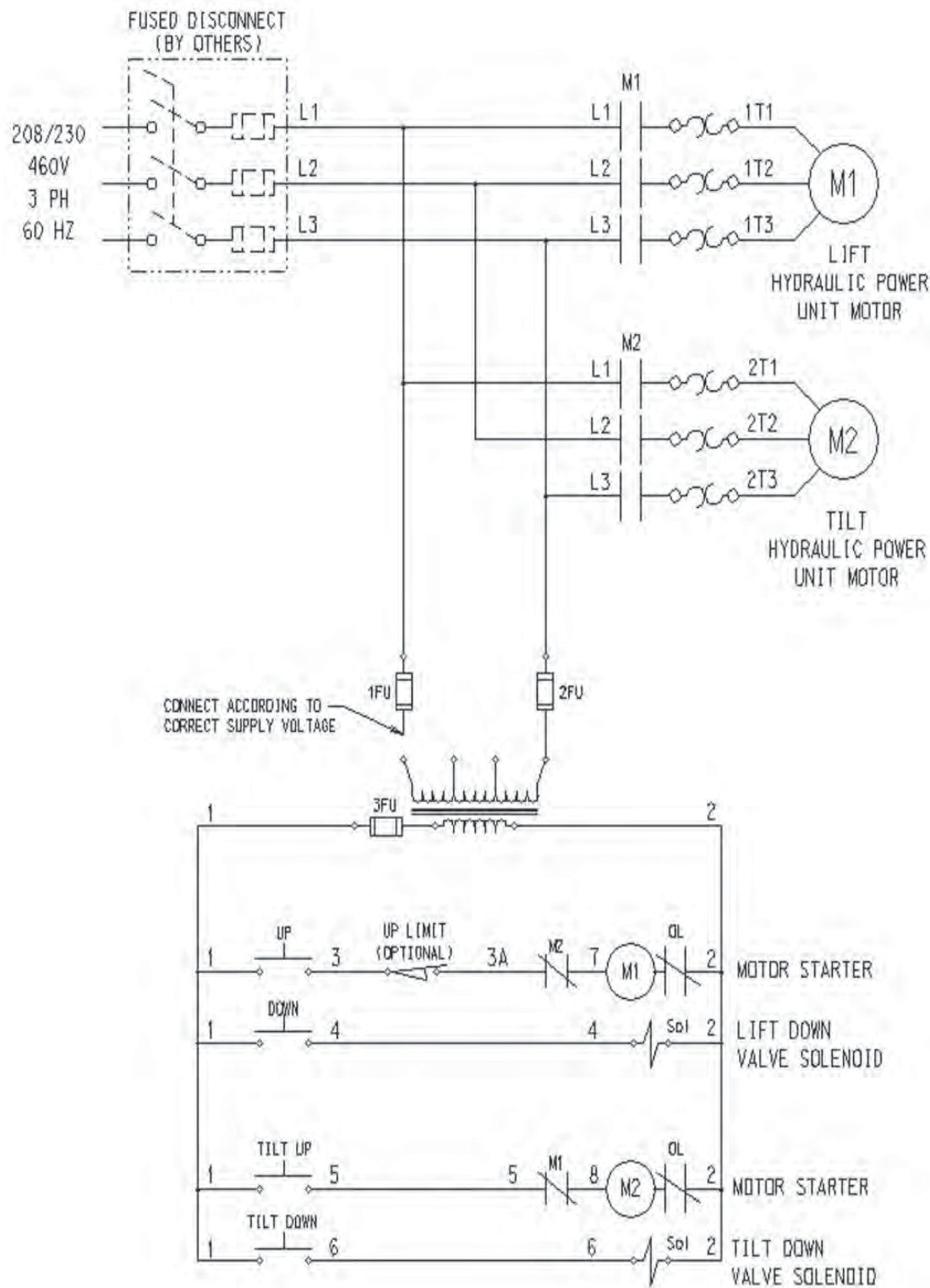

NOTE:
 UPPER TRAVEL LIMITSWITCH IS OPTIONAL.
 IF UP LIMIT IS ABSENT, CONNECT WIRE 3
 DIRECTLY TO NC CONTACT ON MOTORSTARTER.

Figure 15. Electrical connections for Three Phase AC

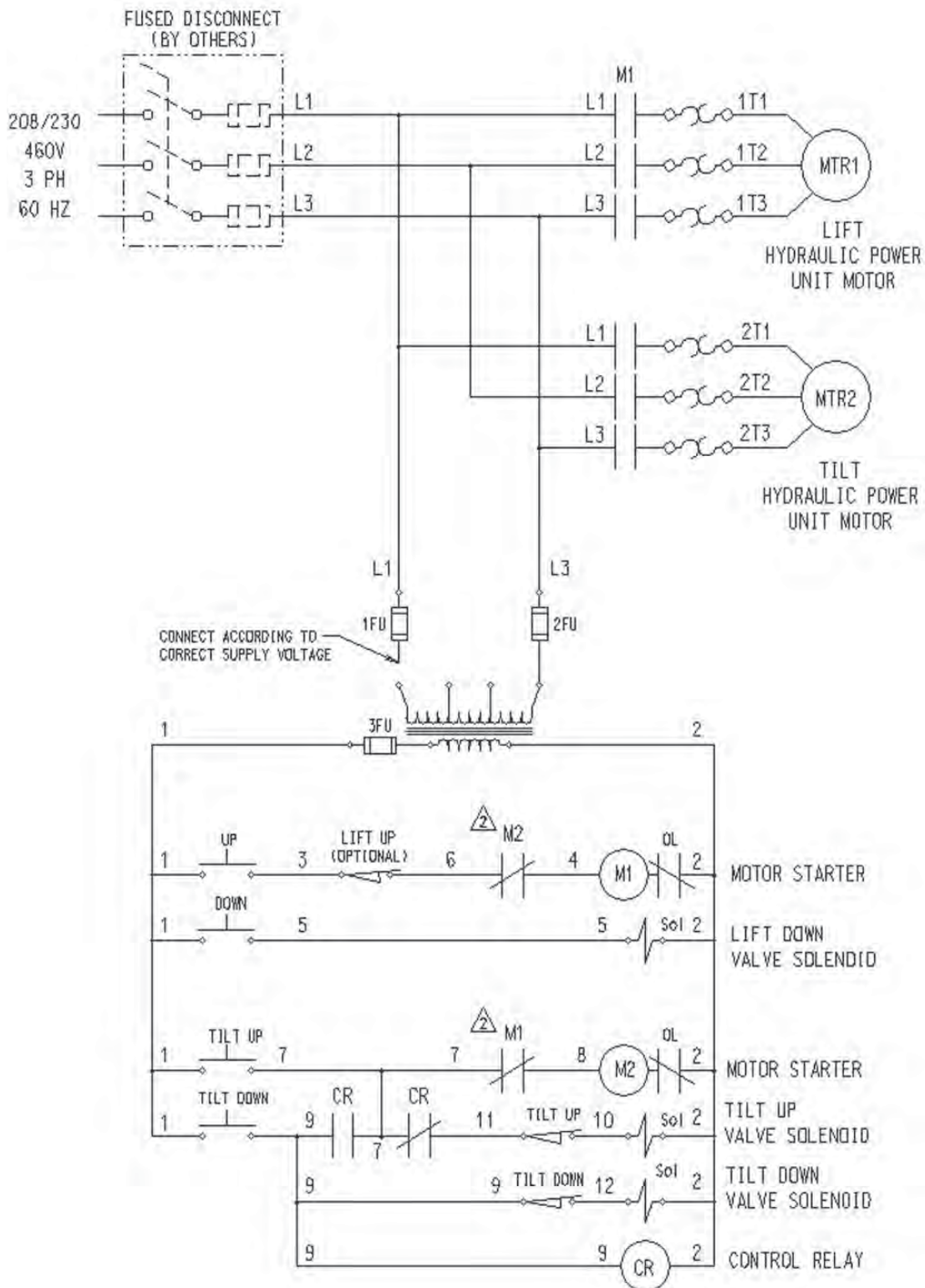

NOTE:

- 1.) THIS DIAGRAM MAY ALSO BE USED WHEN FOOT SWITCHES ARE USED IN PLACE OF PUSHBUTTONS.
- 2.) IF LIFT UP LIMIT SWITCH IS ABSENT RUN WIRE #3 DIRECTLY TO THE N.C. CONTACT ON M2 MOTOR STARTER.

Figure 16. Hydraulic Schematics for Single Phase AC

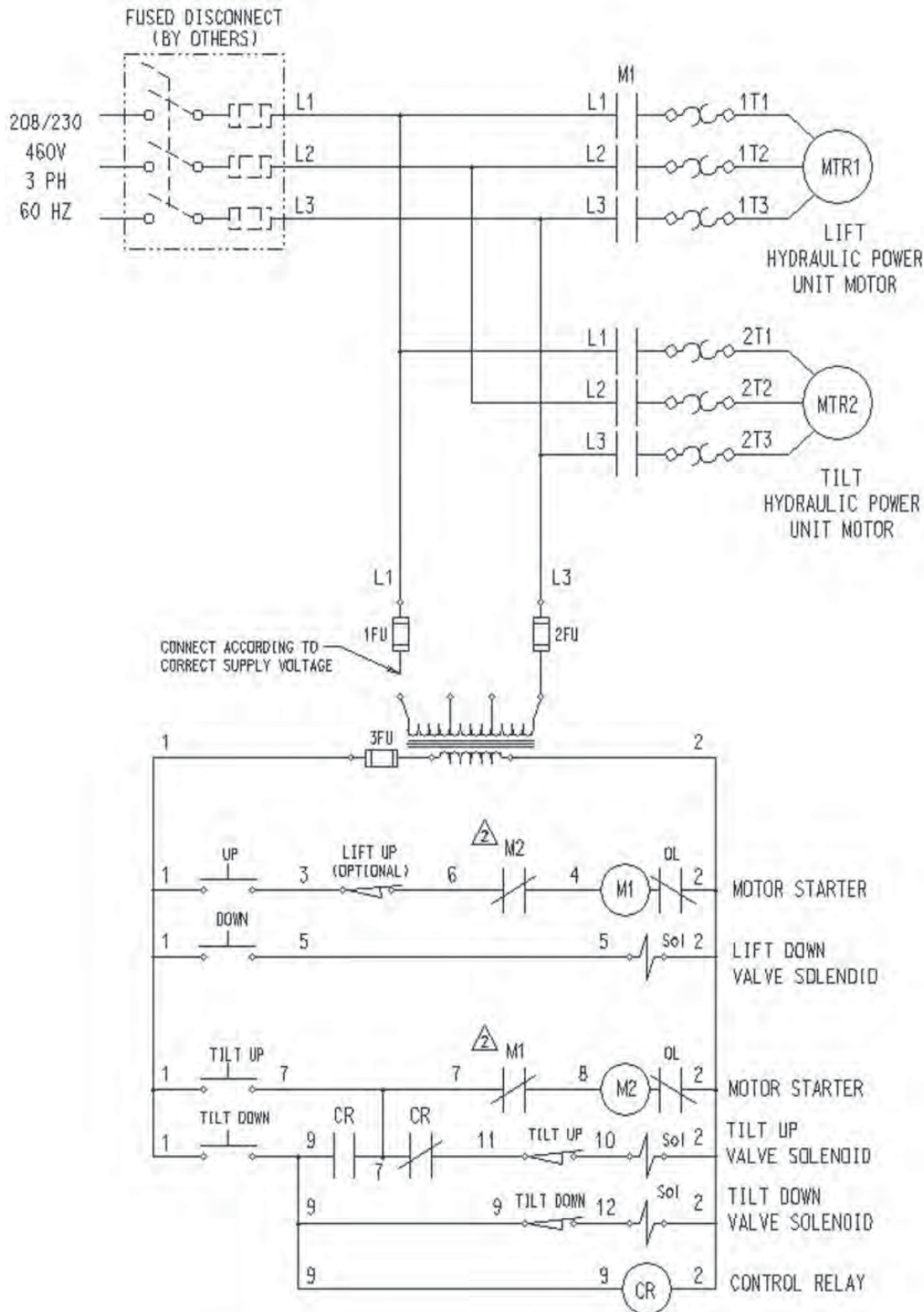

NOTE:

- 1.) THIS DIAGRAM MAY ALSO BE USED WHEN FOOT SWITCHES ARE USED IN PLACE OF PUSHBUTTONS.
- 2.) IF LIFT UP LIMIT SWITCH IS ABSENT RUN WIRE #3 DIRECTLY TO THE N.C. CONTACT ON M2 MOTOR STARTER.

Figure 17. Hydraulic Schematics for Three Phase AC

RETURN MATERIALS AUTHORIZATION (RMA) PROCEDURES

The Southworth Return Authorization (RMA) Procedure is provided as a courtesy to our customers in the event a product or a component may need to be returned.

If a customer wishes to return a Southworth product, the first step in the process is to request an RMA number from the Customer Service Department. This request must be made on or before the thirtieth (30th) calendar day following the date of Southworth's invoice for the merchandise being returned.

The RMA number must appear on the outside of any packaging material for a return to be accepted and processed at Southworth manufacturing facility. Customers shipping returns back to Southworth, from the continental US, Canada or Mexico have thirty (30) days from the effective date of the RMA to have the merchandise arrive freight prepaid at Southworth. If the RMA number is missing or expired (beyond 30 days) it may be refused at Southworth. If any RMA is expired, contact the Customer Service Department before returning to Southworth.

All RMA's are subject to the appropriate restocking fees. All credits issued are less restocking fees as applicable, plus any assessed outbound/inbound in-transit damages.

Return addresses: please refer to your RMA for the specific address to which your product should be returned. Southworth has multiple facilities and returning goods to other than the designated location will result in goods being refused.

Please contact the Customer Service Department at anytime regarding questions to this procedure.

Southworth Products Corp
P.O. Box 1380
Portland, Maine 04104
PH: 1-800-743-1000 or 1-207-878-0700 FAX: 207-797-4734
www.SouthworthProducts.com

2 YEAR WARRANTY

Southworth Products Corp warrants this product to be free from defects in material or workmanship for a period of 2 years of single shift usage from date of shipment, providing claim is made in writing within that time period. This warranty shall not cover modified designs for special applications, failure or defective operation caused by misuse, misapplication, negligence or accident, exceeding recommended capacities, failure to perform required maintenance or altering or repairing, unless alteration is authorized by Southworth Products Corp. Except as set forth herein, there are no other warranties, express or implied, including the warranties of merchantability and fitness for a particular purpose, all of which are hereby excluded.

Southworth Products Corp makes no warranty or representation with respect to the compliance of any product with state or local safety or product standard codes, and any failure to comply with such codes shall not be considered a defect of material or workmanship under this warranty. Southworth Products Corp shall not be liable for any direct or consequential damages arising out of such noncompliance.

Southworth Products Corp's obligation under this warranty is limited to the replacement or repair of defective components at its factory or another location at Southworth Products Corp's discretion. This is buyer's sole remedy. Except as stated herein, Southworth Products Corp will not be liable for any loss, injury or damage to persons or property, nor for direct, indirect, or consequential damage of any kind, resulting from failure or defective operation of said product.

This warranty may be altered only in writing by Southworth Products Corp, Portland, Maine.

SOUTHWORTH

SOUTHWORTH PRODUCTS CORP
P.O. Box 1380, Portland, ME 04104-1380
Telephone: (800) 743-1000 • (207) 878-0700
Fax: (207) 797-4734
www.SouthworthProducts.com

SOUTHWORTH

We'll Show You How

Southworth is *the* world class supplier of products designed to improve productivity and enhance safety. Our staff has over 400 years of engineering experience. If one of our standard products does not meet your needs, we can design custom equipment specifically suited to your material handling application.



Spring Loader



Lift with Turntable



Portable Tilters



Dock Lifts



Palletizing



Portable Lifts



Stretchwrapping



Positioning



Lift & Tilt



Floor to Mezzanine Lifts

For more information, contact Southworth Products
Telephone 800-743-1000 - Fax 207-797-4734
Email: sales@SouthworthProducts.com