

OWNER'S MANUAL

ZTU and ZTU Pan E-Z Reach Container Tilters



Model # _____

Serial # _____

Placed In Service _____

SOUTHWORTH

Southworth Products Corp
P.O. Box 1380/ Portland, ME 04104-1380
Telephone: 207-878-0700 Fax: 207-797-4734

January 2011

Introduction

The Southworth ZTU and ZTU-Pan E-Z Reach Container Tilters are designed to position parts containers at a convenient working height. This allows workers to reach the parts without bending or stretching. Both types feature floor-height roll-on designs. This allows containers to be placed directly on the tilter in a single step, using a fork truck or hand pallet truck. The ZTU models have two separate lifting arms and are designed to lift loads which are delivered by a pallet jack. On the ZTU-Pan units, the two arms are connected by a pan which may be lowered to floor level. This allows a load to be tilted while it is still on the pallet. The two types are identified on the front cover. Two models of each type are available for maximum load capacities of 2,000 lbs and 4,000 lbs. Using a pushbutton control the operator can position the load at any angle between 0° and 85°.

This manual contains instructions on the safe and proper installation, use, and maintenance of a ZTU-or ZTU-Pan series tilter. Be sure that this manual is available to the people who install, use, or service the E-Z Reach unit. Be sure that all personnel read this manual before they install, use or service the unit.

EZ-Reach units may be used in a wide variety of industrial settings. The instructions in this manual are not necessarily all-inclusive, as Southworth cannot anticipate all conceivable or unique situations. In the interest of safety, please read this whole manual carefully. Please understand the material in this manual before you install, use, or service the E-Z Reach unit. If you have any questions about any of the instructions in this manual, please contact Southworth Products Corporation.

Southworth's product warranty is shown on the rear cover of this manual. This instruction manual is not intended to be or to create any other warranty, express or implied, including any implied warranty of merchantability or fitness for a particular purpose, all of which are hereby expressly excluded. As set forth more specifically in the product warranty, Southworth's obligation under that warranty is limited to the repair or replacement of defective components, which shall be the buyer's sole remedy, and Southworth shall not be liable for any loss, injury, or damage to persons or property, nor for any direct, indirect, or consequential damage of any kind resulting from the EZ-Reach Container Tilter.

Contents

INTRODUCTIONPage 2

SAFETY 4

INSTALLATION INSTRUCTIONS 4

 Preparation 4

 Positioning the Unit..... 4

 Electrical Connections 5

 Testing 5

OPERATING INSTRUCTIONS 8

 Loading the Unit 7

 Raising the Tilt Platform 8

 Moving the Unit 9

MAINTENANCE & TROUBLESHOOTING 10

 Hazards 10

 Routine Periodic Maintenance 10

 Changing the Hydraulic Fluid11

TROUBLESHOOTING CHECK LIST 11

REPACKING THE CYLINDER 13

ORDERING REPLACEMENT PARTS 15

WARRANTY 18

List of Figures

Fig. 1 Installing the Unit 5

Fig. 2 Pinch Points 6

Fig. 3 Safety Markings 7

Fig. 4 Push the Load Back..... 7

Fig. 5 Correct Load Center Ranges 8

Fig. 6 Center the Load 8

Fig. 7 Don't Overfill the Container 9

Fig. 8 Hydraulic Pump..... 12

Fig. 9 Down Valve 12

Fig. 10 Electrical Diagram..... 14

Fig. 11 Hydraulic Diagram 14

Fig. 12 Parts Identification - Side View (ZTU-2, ZTU-4) 15

Fig. 13 Parts Identification - Front View (ZTU-2, ZTU-4, ZTU-2 Pan)..... 16

Fig. 14 Parts Identification - Front View (ZTU-4 Pan)..... 16

Fig. 15 Hydraulic Oil Specifications 17

Safety

The safety of all persons installing, using, servicing, or working near the EZ-Reach unit is of paramount concern to Southworth. The EZ-Reach unit is a powerful machine with moving parts, and is **capable of causing personal injury if proper precautions are not taken**.

Therefore, throughout this manual, Southworth has identified certain hazards which may occur in the use of the EZ-Reach unit, and provided appropriate **instructions** or **precautions** which should be taken to avoid these hazards. In some cases, Southworth has also pointed out the **consequences** which may occur if Southworth's instructions or precautions are not followed. Southworth uses the following system of identifying the severity of the hazards associated with its products:

DANGER – Immediate hazard which will result in severe personal injury or death.

WARNING – Hazard or unsafe practice that could result in severe personal injury or death.

CAUTION – Hazard or unsafe practice that could result in minor personal injury or property damage.

Please read and follow this instruction manual, including all safety instructions and precautions, carefully and completely.

Installation Instructions

Preparation

1. Before you start to use the unit, check for local codes and ordinances which may apply. It is your responsibility to obtain any necessary permits.
2. Read all of these installation instructions carefully. Be sure to read and understand all of the warnings.
3. The unit should only be used indoors, or it should be protected from the weather.

WARNING!

- **Protect the unit from rain or moisture. If the electrical parts in the power unit get wet, workers may be hurt by electrical shock. The electrical parts may fail if they are wet.**

CAUTION!

- **This unit has an electric motor that can create sparks. Don't use the unit in an area where flammable gases may be present.**
4. You will need these tools to install the unit:
 - A crane or lift truck that can lift the unit safely.
 - Shims and lag bolts.
 - A masonry drill and bit to drill the holes for the lag bolts.
 - Wrenches to fit the lag bolts.

POSITIONING THE UNIT

1. Remove the shipping material and unskid the unit. You will need a crane or lift truck that can lift the unit safely.

CAUTION!

Do not try to move the lift by supporting the tilt platform. One end of the tilt platform is free.

On the front of this manual, write down the model number, serial number, and date the unit is placed in service. You can find the model number and serial number on the nameplate.

WARNING!

If the unit is mounted on an unstable surface, it may tip over when it is in use. You may be hurt, and the unit and load may be damaged.

ELECTRICAL CONNECTIONS

1. The unit has a power cord which is 10' long (305 cm). At each location where you want to use the unit, be sure a three-prong outlet is available. Each circuit should have a 20 amp dedicated circuit breaker or fuse.

DANGER!

The unit uses a power supply of 115 volts AC. This voltage can kill you. Don't work with the electrical parts unless you are a qualified electrician.

WARNING!

To avoid fire danger, be sure to provide a circuit breaker or fuse.

2. The foot switch assembly is attached to the unit by a 3' cable (91 cm). Position the control box in a convenient location near the unit.

3. Check the level of the hydraulic fluid in the tank. In order to check the level, lower the unit completely and unplug the power cord. Remove the rear cover on the unit. The tank is located below the motor and pump. The tank is normally filled through the vent plug (connected to the clear plastic vent line). To check the level, remove the vent plug. Use a dipstick to check the oil level. The oil should be 1/2" to 3/4" (13 to 19 mm) below the top of the tank. Add oil as necessary.

Testing

1. Clear the area around the unit, and warn others to stay away from the unit. Remove any loose wires, lumber, or other materials which might get in the way of the unit as it raises or lowers.

2. Operate the unit through its full range of travel. The unit should rise smoothly with a quiet humming sound, and lower smoothly and quietly. Raise and lower the unit a few times to check the clearances around the tilt platform.

WARNING!

As the tilt platform moves up and down, "pinch points" are created at the places shown in Fig. 2. If you are standing too close to the unit when it is moving, your arm or leg may be caught in the moving parts, and you may be hurt. Stay away from the pinch points when the unit is moving.

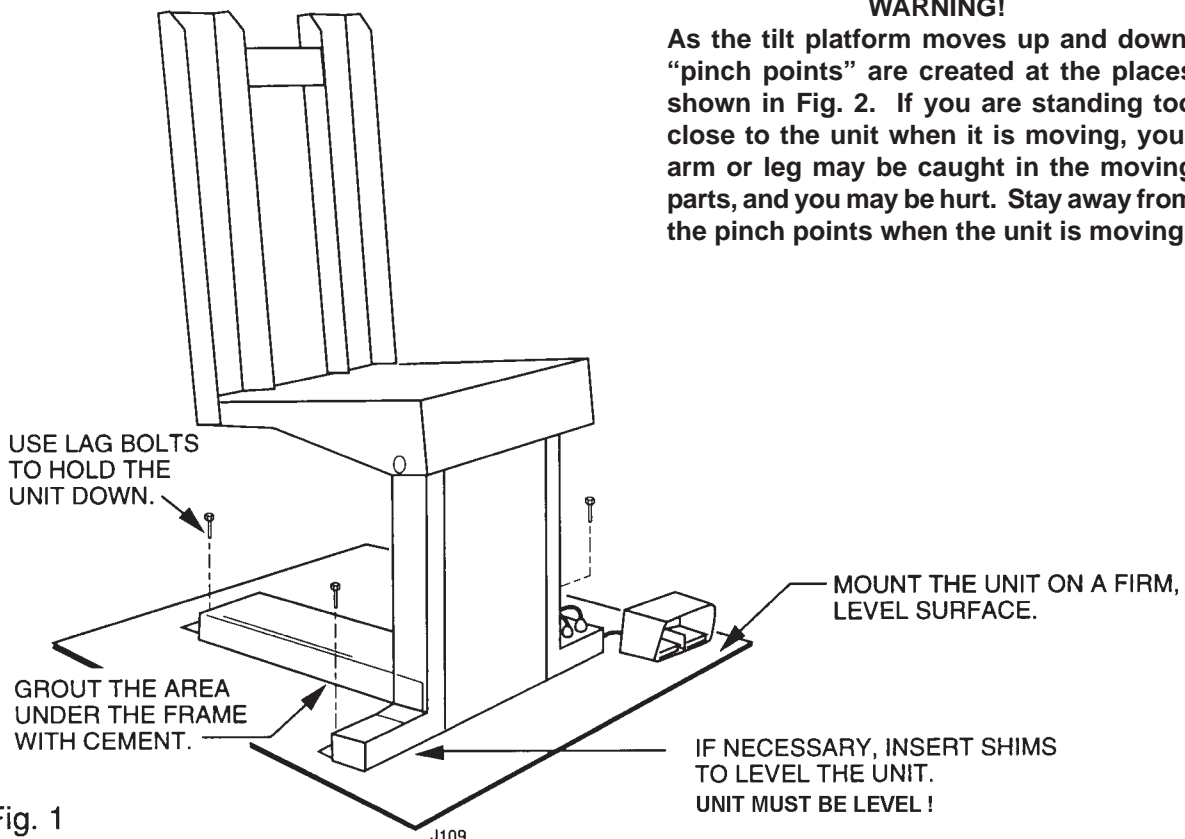

Fig. 1
Installing the unit

3. If the unit is lowering too quickly or too slowly, you can change the “down speed” by adjusting the flow control.

If you want the tilt platform to lower more slowly, turn the control clockwise up to 1/4 turn at a time. If you want the tilt platform to lower more quickly, turn the control counterclockwise up to 1/4 turn. Don't move the control more than 1/4 turn at a time.

4. Test the unit with the rated load. If the unit does not rise, and you hear a loud squealing noise, the pressure relief valve is operating. Contact Southworth for instructions.

WARNING!

Don't continue to use the unit if this happens – the pump will overheat very quickly, and may be permanently damaged. Do not try to adjust the relief valve. If you change

the setting on the relief valve, you may overwork the unit. This can cause the unit to fail suddenly, and you may be hurt.

5. Clean up any spilled hydraulic fluid. Spilled hydraulic oil is slippery, and may present a fire hazard. If you clean up any spilled fluid, you will be able to tell right away if the unit begins to leak.

5. Figure 3 shows the safety labels on this unit. Check to be sure all of the labels are in place.

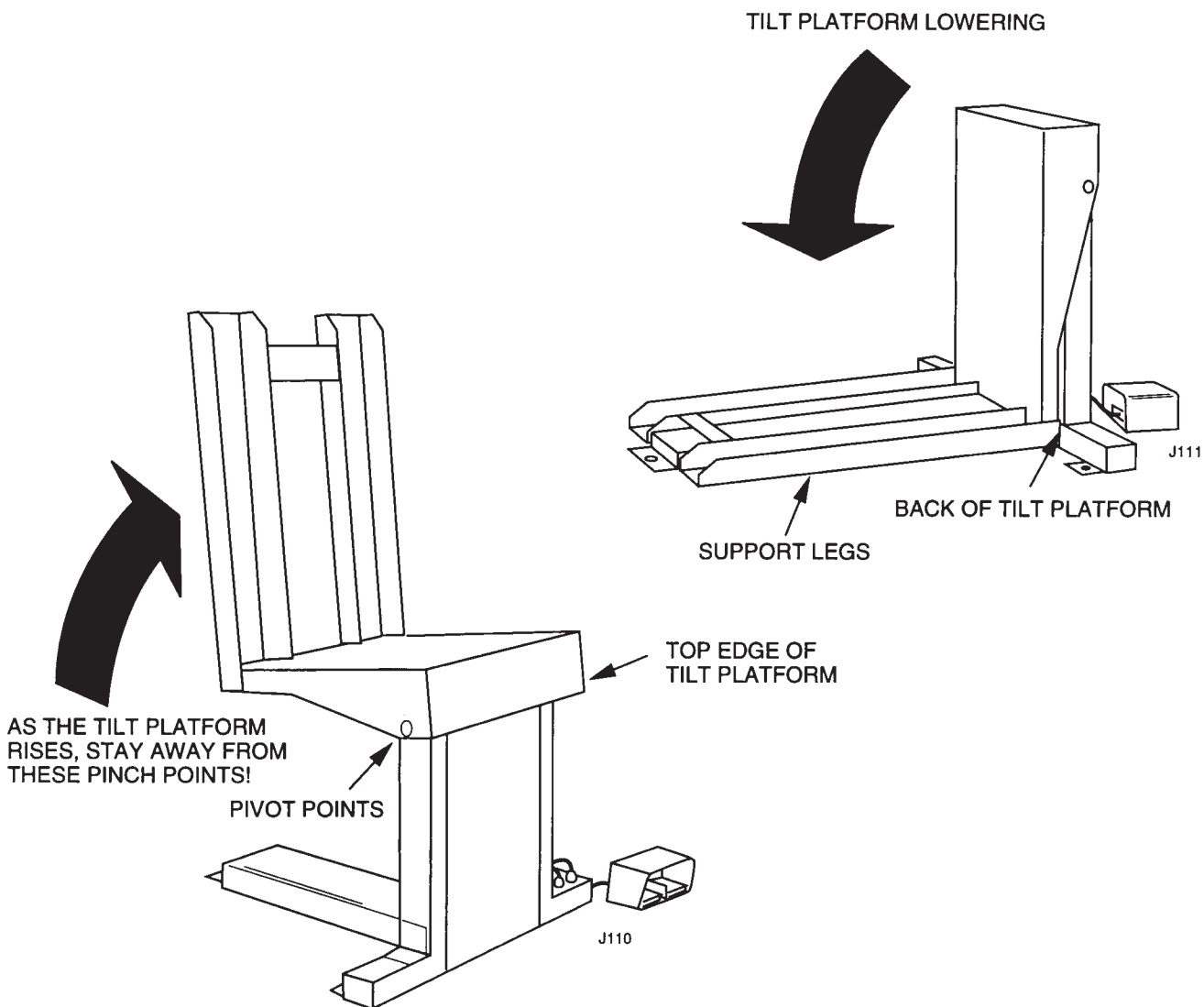

Fig. 2. Pinch Points

A statement of voltage:

**115 VOLTS
1 PHASE**

A warning to keep away from the moving parts of the lift:

**CAUTION
DO NOT PUT HANDS UNDER TABLE
DO NOT PUT FEET UNDER TABLE
DO NOT STAND OR SIT ON TABLE**

A statement of rated capacity
(example shown here):

**CAPACITY
2000 LBS.**

A note regarding the level of the hydraulic fluid:

**TANK TO BE FULL ONLY WHEN
CYLINDER IS COLLAPSED**

The tilt platform is painted safety orange.

(Note: These are samples of typical warning labels. The labels on your machine may be slightly different.)

Fig. 3. Safety Markings

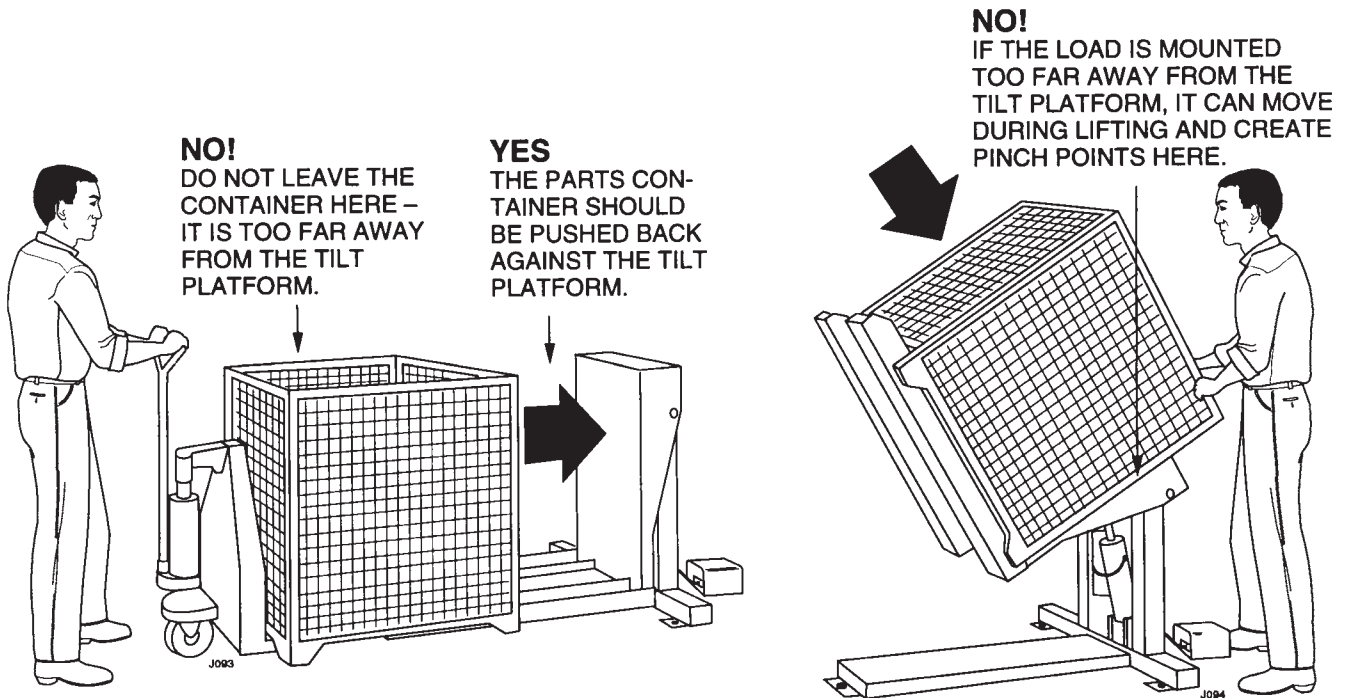

Fig. 4. Push the Load Back

Operating Instructions

Loading the unit

1. Before operating the unit, please read and understand this entire section.

DANGER!

This unit uses a power supply of 115 Volts AC. This voltage can kill you. Don't work with the electrical parts unless you are a qualified electrician!

2. Load the unit correctly.

Before lifting, be sure the lifting container is pushed against the tilting platform, as shown in Fig. 4. If you do not do this, the container may slide down and create dangerous "pinch points."

Be sure that the load weighs no more than the maximum rated for the unit. The maximum rated load is listed on the tilt platform. Remember that the lifting container may weigh 75 lbs. or more. Push the load back against the tilt platform.

WARNING!

The tilt platform should always be pushed against the load. If the load is placed far out on the lifting arms, the unit may not be able to lift the full rated load safely. See Fig. 5.

ZTU Models - Load center may be up to 20" from the tilt platform

ZTU-2 Max. load 2,000 lb.

ZTU-4 Max. load 4,000 lb.

ZTU Pan Models - Load center may be up to 24" from the tilt platform

ZTU-2 Pan Max. load 2,000 lb.

ZTU-4 Pan Max. load 4,000 lb.

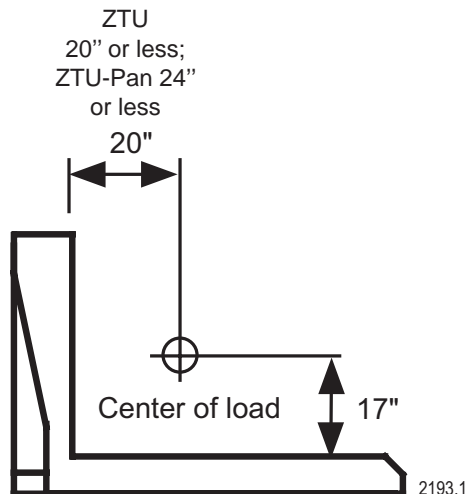

Fig. 5. Correct Load Center Ranges

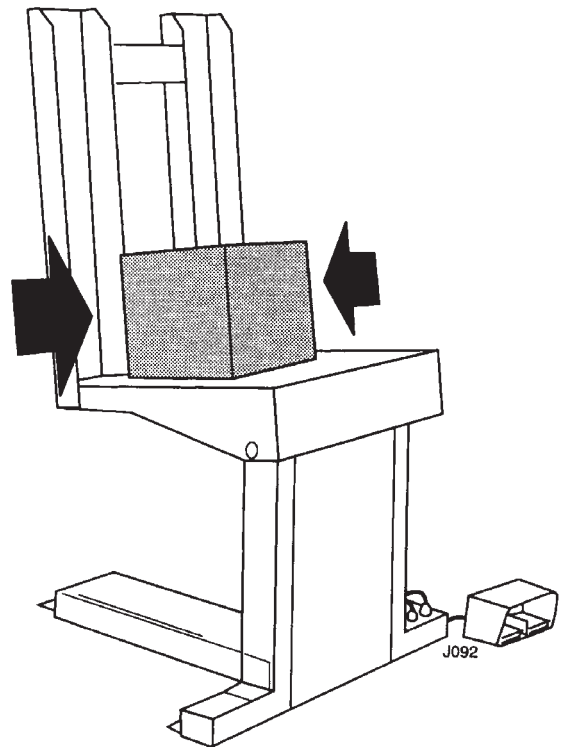

Fig. 6. Center the Load

For ZTU models, the load center may be up to 20" from the tilt platform. For ZTU-Pan models, the load center may be up to 24" from the platform. When lifting, always keep the load center as close as possible to the tilt platform. When either kind of unit is lifting the type of load for which it was designed, the unit will be able to lift the full rated load. If a unit is used for a different type of load, with a different center of load, it may not be able to lift the rated load safely. If you plan to begin lifting a different type of load, consult the factory for details.

WARNING!

Don't try to lift a load that exceeds the maximum rating. Only lift a load if the center of load is within the allowable range. If you do not follow these rules, the unit may fail suddenly. Someone may be hurt, and the unit and load may be damaged.

3. The load should be balanced in the side-to-side direction. Whenever possible, place the load in the center of the tilting platform, as shown in Fig. 6. If the load is off-center on the pallet, place the heaviest part of the load near the back of the tilt platform – never near the front!

4. Sometimes the unit may be used to lift parts which can roll. If possible, stack the parts in the parts container so they cannot roll. Do not overfill the lifting container. See Fig. 7. If the container is too full, some of the parts may roll out of the front of the container.

WARNING!

Don't overfill the lifting container. As the unit lifts, some of the parts may roll out of the front of the container. The falling parts may hurt you or damage the unit.

Raising the Tilt Platform

1. Before raising the tilt platform, be sure all workers are clear of the unit.

WARNING!

As the tilt platform moves up and down, "pinch points" are created as shown in Fig. 2. Stay away from these pinch points! Part of your body or clothing may become caught, and you may be hurt. Do not put your hands or feet under the tilt platform. Do not stand or sit on the tilt platform.

2. Before lifting, be sure the parts container is pushed up against the tilt platform, as shown in Fig. 4. Be sure the load is balanced side-to-side, as shown in Fig. 6.
3. Plug in the AC cord. Be sure the cord cannot become caught in the moving parts as the platform raises.

WARNING!

Be sure that the electrical power cord will not be pinched by the unit as it raises or

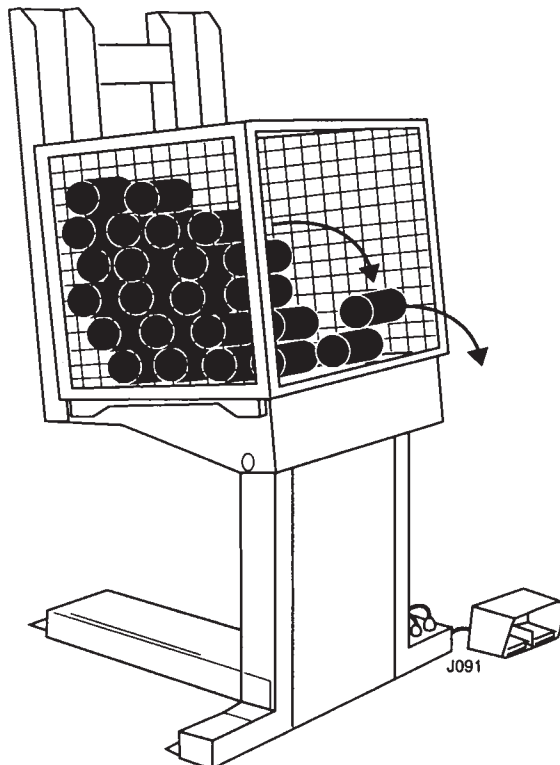

Fig. 7. Don't Overfill the Container

lowers. If you allow the cord to be pinched, it may be broken. This can create a shock hazard. To avoid this problem, always check the position of the cord before you start to raise or lower the unit.

5. Operate the unit. Press and hold the Up button to raise the tilt platform, and Down to lower it. If the unit does not operate right away, unplug the power cord and call a qualified maintenance worker.

WARNING!

This power unit contains a hydraulic pump that is capable of developing excessive pressure. A pressure relief valve is used to set the pressure at a desired level. Tampering with, adjusting, modifying or removing the relief valve is extremely dangerous and is not recommended. Only a trained hydraulics technician, using a calibrated hydraulic pressure gauge to assure the proper pressure setting is achieved, should make adjustments to the relief valve.

Moving the Unit

1. Before moving the unit, always lower the tilt platform. You should do this even if the unit is not loaded.

WARNING!

If you try to move the unit while the tilt platform is raised, the unit may be unstable. You may be hurt, and the lift or load may be damaged.

2. Unplug the power cord. Place the end over the top of the unit, so the cord does not drag.

CAUTION!

As you move the unit, do not allow the power cord to drag on the floor. The cord may catch on something and stop the unit suddenly.

3. Before moving, release the floor lock.
4. Always roll the unit across a stable, solid surface.

WARNING!

If the floor is not stable or solid, the unit may tilt over. You may be hurt, and the unit or load may be damaged.

Maintenance and Troubleshooting

All servicing should be done by qualified personnel. Qualified personnel should be able to read and understand wiring and hydraulic diagrams. They should be able to troubleshoot live electrical circuits safely and in accordance with accepted practice. **For safety's sake**, if in doubt, please contact your dealer or Southworth Products Corporation Customer Service Department at (800) 743-1000 or (207) 878-0700.

Before servicing the unit, please read and understand all of this section and the section entitled "Operating Instructions."

Hazards

There are several hazards you should be aware of as you service the unit:

DANGER!

- **The unit uses a power supply of 115 Volts AC. This voltage can kill you. Do not work on the electrical parts unless you are a qualified electrician!**

WARNINGS!

- **As the unit moves up and down, "pinch points" are formed as shown in Fig. 2. Keep hands, feet, and loose clothing away from these pinch points. If your hand or arm or a part of your clothing is caught, you may be hurt.**
- **Before performing any maintenance on the unit, lower the tilt platform completely. Failure to do so could result in severe personal injury.**
- **The relief valve has been included for the protection of all of the workers who use the unit. Don't change the relief setting! If the relief valve does not open when it should, the unit may fail. Someone may be hurt, and the unit and load may be damaged.**
- **If the hydraulic fluid is released under high pressure, it can cause personal injury. Before you open any part of the hydraulic system, be sure to release the hydraulic pressure. You can do this by lowering the tilt platform all the way down.**
- **The warning labels have been included for the safety of the operator. If the labels are worn or missing, or have been painted over, replace them before releasing the lift for operation. Fig. 3 shows the safety markings on this unit.**

Routine Periodic Maintenance

Every month:

Visually inspect the pins and bushings at each end of the cylinder(s) for signs of wear. Also check the pivot pins at both sides of the tilt platform. If any of these parts are worn, contact Southworth for repair instructions.

- Apply oil or WD-40 to the parts listed in the last step.

Note: Although the bushings are "lifetime lubricated" Teflon® bushings, their performance may be extended by additional periodic lubrication.

- Check the level and appearance of the hydraulic fluid. In order to check the level, lower the unit completely and unplug the power cord. Remove the rear cover on the unit. Lower the platform. Remove the red plastic vent plug on top of the hydraulic tank, and use a dipstick to check the oil level. When the platform is fully lowered, the oil should be about 1/2 to 3/4 inches below the top of the tank. Add oil if necessary. Change the oil if it has darkened, or feels gritty or sticky.

CAUTION!

It is important to use hydraulic fluid with the correct grade and properties. See the hydraulic oil specification in Fig. 17 of this manual.

Every six months or 500 hours of operation, whichever comes first:

- Check all of the hydraulic fittings and hoses, and tighten the connections if necessary. Sometimes the fittings can be worked loose by the vibrations from the power unit.

WARNING!

If a hydraulic fitting becomes loose, or if a hydraulic hose breaks, the hydraulic fluid may escape from the system under pressure. If the tilt platform is raised when this happens, it can drop quickly. Someone may be hurt, or the unit or load may be damaged. To avoid this problem, inspect all of the hydraulic hoses and fittings regularly, and replace them if they are worn or damaged.

- The clear plastic vent line(s) and the cylinder rod(s) should be free of hydraulic fluid. If you find much fluid in either place, the cylinder seals may be leaking. (It is also possible the tank may be overfilled.) If the worn parts must be replaced, see the section on "Repacking the Cylinder(s)."

- Disassemble the down valve as shown in Fig. 9. Blow the valve plunger clean with compressed air. Reassemble the valve and reinstall it.
- Drain and discard the hydraulic fluid. The suction filter is in the tank, at the point where the suction line runs out to the pump. Unscrew the hydraulic line, then remove the filter. Blow the filter clean with compressed air. Reinstall the filter in the tank and reassemble the hydraulic line.
- Refill the tank with new hydraulic fluid.

CAUTION!

If you continue to use fluid after it has “worn out,” the moving parts in the system will wear more quickly.

- Be sure all of the warning labels are in position and legible. **The warning labels are intended to protect your workers.** If the labels are missing, or if they have been painted over, replace them.

Changing the Hydraulic Fluid

The procedure depends on the type of unit you have. In order to change the fluid, lower the tilt platform completely and unplug the power cord. Remove the rear cover on the unit.

ZTU-2 (2,000 capacity unit) - 120V AC unit: The tank is located below the motor and pump. The tank is normally filled through the vent plug (connected to the clear plastic vent line). Since it is very hard to reach this plug from the rear of the unit, and the tilt platform is stopped in the lowered position, it is easiest to remove the tank.

Disconnect the hydraulic hose which runs to the bottom of the pump. Undo the connection just below the pump. Disconnect the upper end of the clear plastic vent line. Finally, unbolt the tank and remove it.

Remove the vent plug. Pour out the old fluid and add fresh fluid. Use a dipstick to check the oil level. This should be 1/2" to 3/4" (13 to 19 mm) below the top of the tank. Add oil as necessary. Replace the tank and reconnect the hoses.

ZTU-4 (4,000 capacity unit) - 120V AC unit: The tank is located in the left-hand support leg of the unit (when viewed from the rear). See Fig. 14. To drain the tank, loosen the fitting at the bottom of the leg. Remove the filler cap, and check the level with a dipstick. The oil should be 1/2" to 3/4" (13 to 19 mm) below the top of the tank. Add oil as necessary..

Repacking the Cylinder

The lift in the EZ-Reach unit may use several different types of cylinders. To order a repacking kit and to receive instructions, please call the Southworth Parts Department at (800) 743-1000 or (207) 878-0700. When ordering, specify the model number and serial number of the unit.

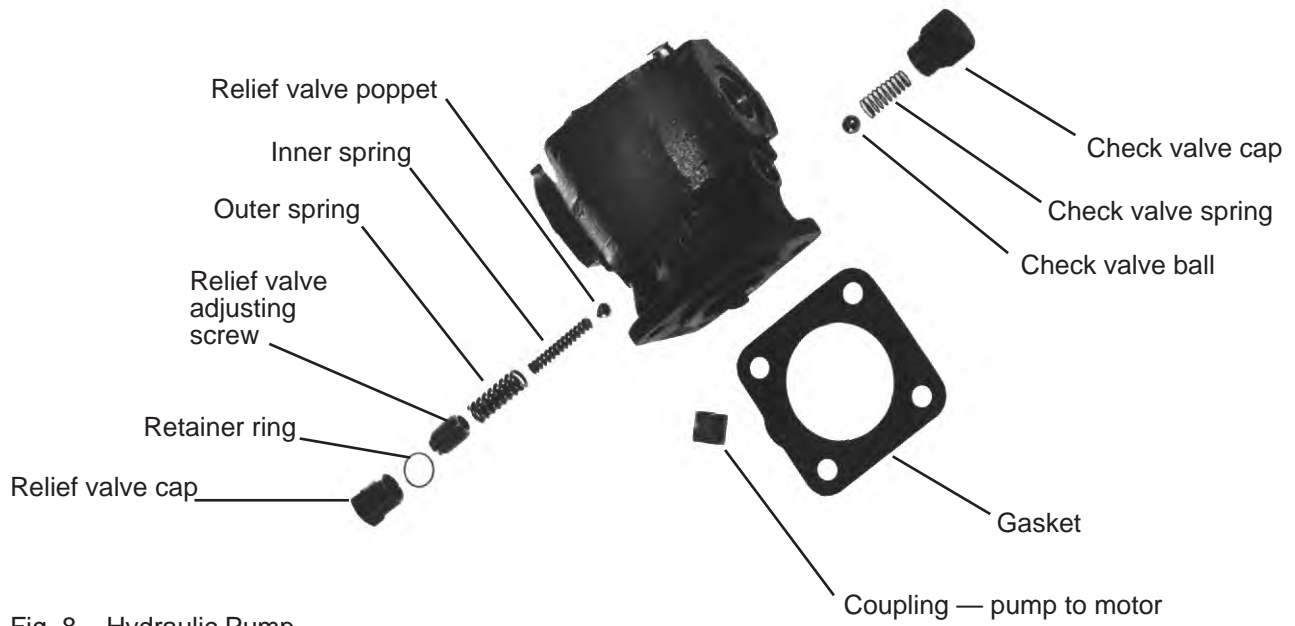

Fig. 8 Hydraulic Pump

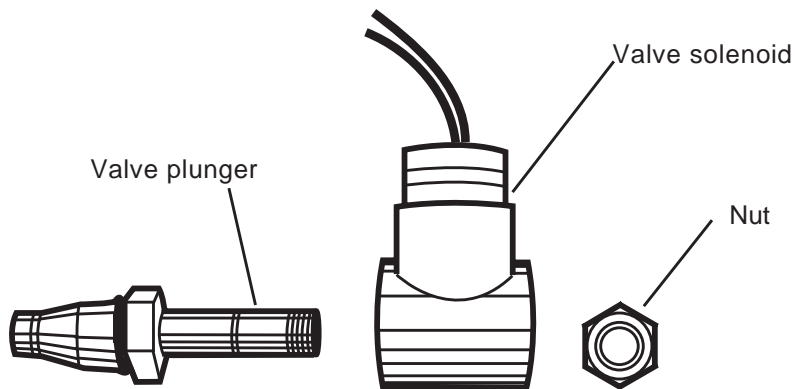

Fig. 9 Down Valve

Problem	Possible Cause	Check This
Tilt Platform will not raise	Battery may need charging	Battery volt level
		Is the charger putting out 12 volts?
		Check that 12 volts is being reached at the motor & motor relay
		Is the charger operating properly?
	Load is too heavy	Verify the load weight
	Unit is low on oil	Inside the tank, make sure the oil is full to the elbow in the filler pipe.
	Tank vent may be plugged.	Look to see that the solid plug is not in place of the vent plug.
Unit elevates but will not hold a load	Suction filter may be clogged.	Remove and clean the suction filter.
	Down valve coil may be energized	Remove the down valve and ensure it is not being energized when the up button is pushed. Check wiring to the down valve.
	Cylinder may be leaking	Check the vent line for signs of oil
Unit fails to lower	Down valve coil may not be energized	Remove the down valve and ensure it is not being energized when the up button is pushed. Check wiring to the down valve.
		Ensure debris is not holding the down valve plunger open.
		Check the vent line for signs of oil

If the steps listed above do not solve the problem, please call the Southworth Products Corp. Customer Service Department at (207) 878-0700.

Troubleshooting

All servicing should be done by qualified personnel. Qualified personnel should be able to read and understand wiring and hydraulic diagrams. They should be able to troubleshoot live electrical circuits safely and in accordance with accepted practice. **For safety's sake**, if in doubt, please contact Southworth Products Corporation at (207) 878-0700.

Before servicing the unit, read and understand this entire section and the section entitled "Operating Instructions."

WARNING!

Before performing any maintenance on this unit, lower the tilt platform completely.

CAUTION!

If the platform will not raise, do not continue to hold the Up button for more than 2 or 3 seconds. You may damage the pump.

WARNING!

Don't change the setting of the relief valve. If you do change the setting, this may cause a hydraulic part to fail. The tilt platform may drop suddenly. Someone may be hurt, and the unit and load may be damaged. The hydraulic parts in the lift are designed to handle a certain amount of pressure. The relief valve is set to relieve this pressure before it becomes too great. The relief valve has been included for the protection of all of the workers who use the unit.

ZTU EZ REACH

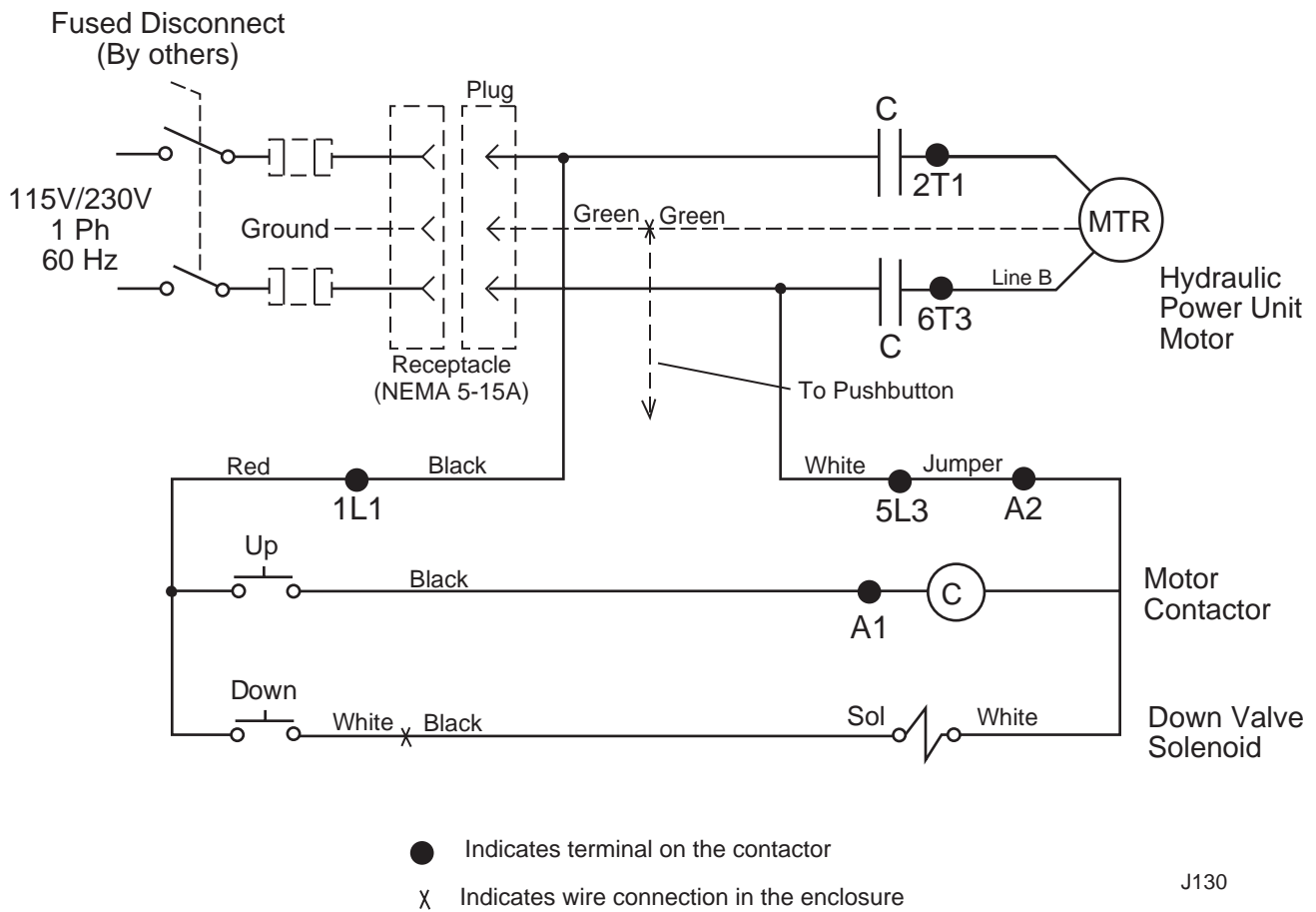

J130

Fig. 10 Electrical Diagram

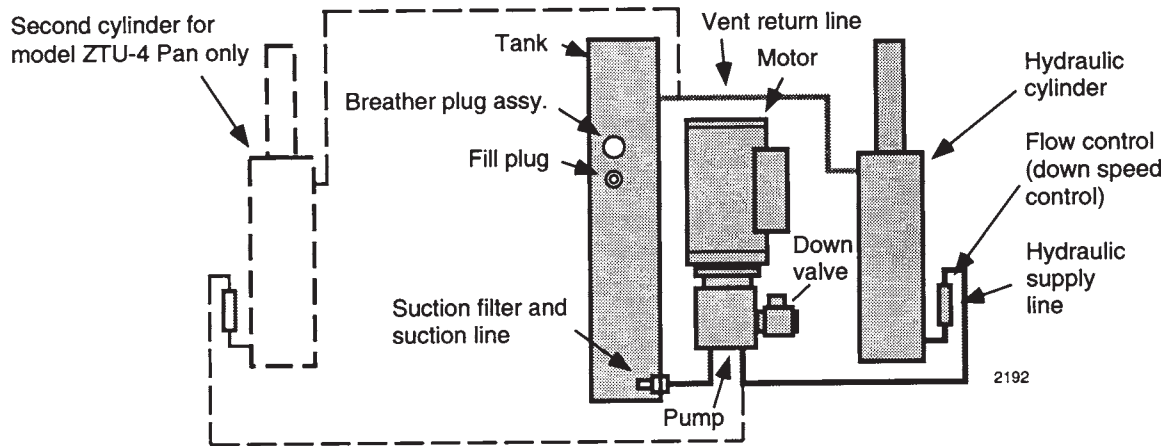

Fig. 11 Hydraulic Diagram

Ordering Replacement Parts

Southworth has carefully chosen the components in your unit to be the best available for the purpose. Replacement parts should be identical to the original equipment. Southworth will not be responsible for equipment failures resulting from the use of incorrect replacement parts or from unauthorized modifications to the machine.

Southworth can supply all replacement parts for your Southworth lift. Key parts are identified in Figures 10 through 16. With your order, please include the model number and the serial number of the unit. You will find these numbers on the nameplate.

To order replacement parts, please call the Parts Department at (800) 743-1000 or (207) 878-0700. Parts are shipped subject to the following terms:

- FOB factory.
- Returns only with the approval of our parts department.

- Payment net 30 days (except parts covered by warranty).
- Freight collect (except parts covered by warranty).

Parts replaced under warranty are on a "charge-credit" basis. We will invoice you when we ship the replacement part, then credit you when you return the assumed substandard part.

Parts Department
 Southworth Products Corp.
 P.O. Box 1380
 Portland, Maine 04104-1380

Telephone: (800) 743-1000
 (207) 878-0700
 FAX: (207) 797-4734

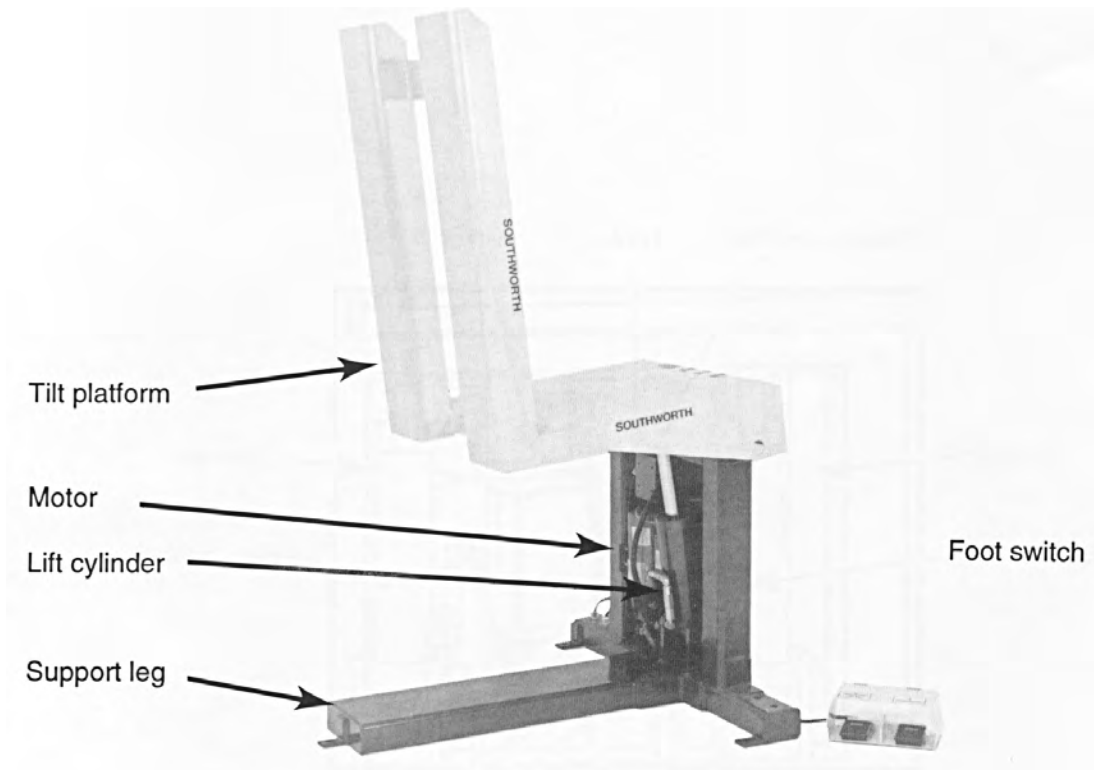

Fig. 12. Parts Identification - Side View
 Models ZTU-2, ZTU-4

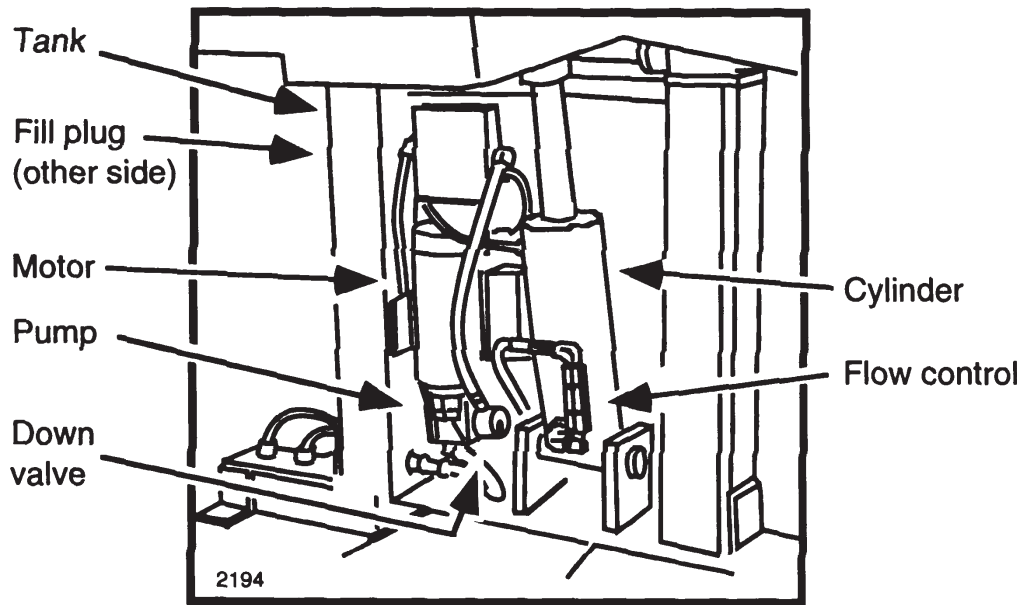

Fig. 13. Parts Identification - Base of unit (viewed from front)
Models ZTU-2, ZTU-4, ZTU-2 Pan

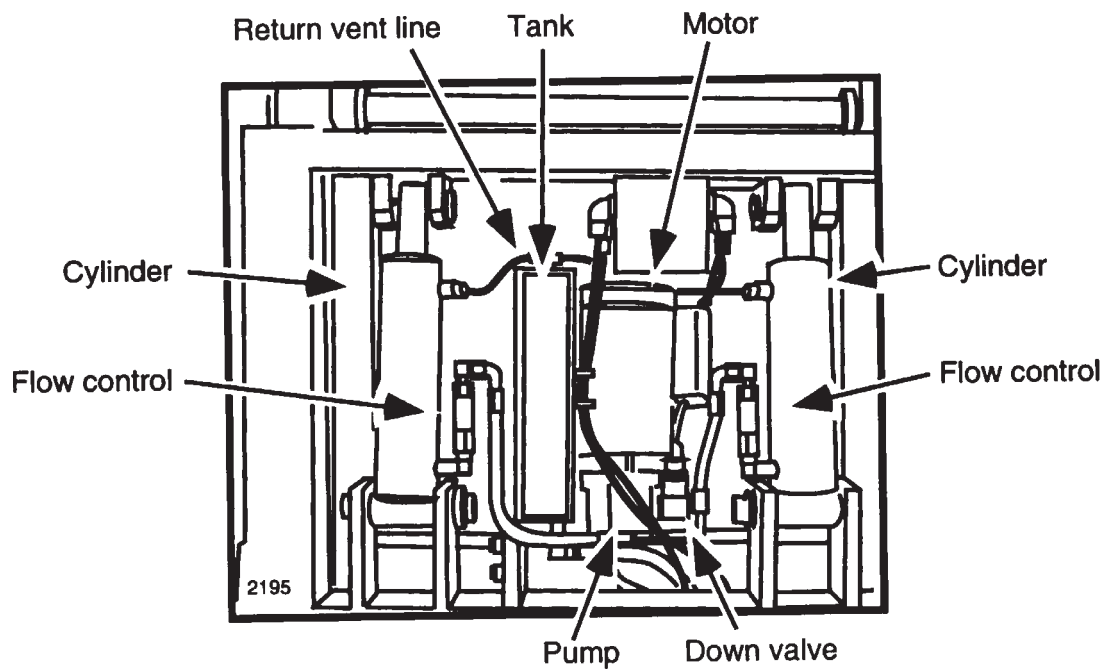

Fig. 14. Parts Identification - Base of unit (viewed from front)
Models ZTU-4 Pan

Table 2 – Hydraulic Oil Specifications

If the lift will be used at normal ambient temperatures, Southworth supplies the unit with Conoco 32 oil. This may be replaced by any other good quality oil with 150 SSU at 100° F and rust and oxidation inhibitors and anti-wear properties.

If the lift will be used at ambient temperatures below 0°F, use aircraft hydraulic oil. Use Type 15 aircraft hydraulic oil.

The following are equivalent to CONOCO 32:

TYPE	MANUFACTURER
DTE 24	EXXON/MOBIL
NUTO H32	EXXON/MOBIL
AMOCO AW32	CHEVRON (AMOCO CO.)
AW32	CITGO

CAUTION!

It is very important to keep the hydraulic oil free of dirt, dust, metal chips, water, and other contamination. Most of the problems with hydraulic systems are caused by contamination in the oil.

2 YEAR WARRANTY

Southworth Products Corp warrants this product to be free from defects in material or workmanship for a period of 2 years of single shift usage from date of shipment, providing claim is made in writing within that time period. This warranty shall not cover modified designs for special applications, failure or defective operation caused by misuse, misapplication, negligence or accident, exceeding recommended capacities, failure to perform required maintenance or altering or repairing, unless alteration is authorized by Southworth Products Corp. Except as set forth herein, there are no other warranties, express or implied, including the warranties of merchantability and fitness for a particular purpose, all of which are hereby excluded.

Southworth Products Corp makes no warranty or representation with respect to the compliance of any product with state or local safety or product standard codes, and any failure to comply with such codes shall not be considered a defect of material or workmanship under this warranty. Southworth Products Corp shall not be liable for any direct or consequential damages arising out of such noncompliance.

Southworth Products Corp's obligation under this warranty is limited to the replacement or repair of defective components at its factory or another location at Southworth Products Corp's discretion. This is buyer's sole remedy. Except as stated herein, Southworth Products Corp will not be liable for any loss, injury or damage to persons or property, nor for direct, indirect, or consequential damage of any kind, resulting from failure or defective operation of said product.

This warranty may be altered only in writing by Southworth Products Corp, Portland, Maine.

SOUTHWORTH

SOUTHWORTH PRODUCTS CORP
P.O. Box 1380, Portland, ME 04104-1380
Telephone: (800) 743-1000 • (207) 878-0700
Fax: (207) 797-4734
www.SouthworthProducts.com

SOUTHWORTH

We'll Show You How

Southworth is the world class supplier of products designed to improve productivity and enhance safety. Our staff has over 400 years of engineering experience. If one of our standard products does not meet your needs, our engineers can custom design equipment specifically suited to your material handling application.



Spring PalletPal Load Leveler



Lift with Flush Mount Turntable



Portable Container Tilters



Dock Lifts



Roll on Level Loaders



Portable Lifts



Stretchwrapping



Positioning

Floor to Mezzanine Lifts



Pallet Rotators



For more information, contact Southworth Products
Telephone (800) 743-1000 Fax (207) 797-4734
Email: salesinfo@SouthworthProducts.com