

REV	REVISION HISTORY - DESCRIPTION	DATE	APPROVED	MF NO.
A	MOVED BOLLARDS AND UPDATED NOTE: CORRECTED CYLINDER VENT SCHEMATIC	01-19-12	SMS	
B	ADDED ALUMINUM BRIDGE PLATE CLEARANCE NOTE	04-03-12	SMS	

FIG. NO. 60036949 1 OF 1

HYDRAULIC DIAGRAM

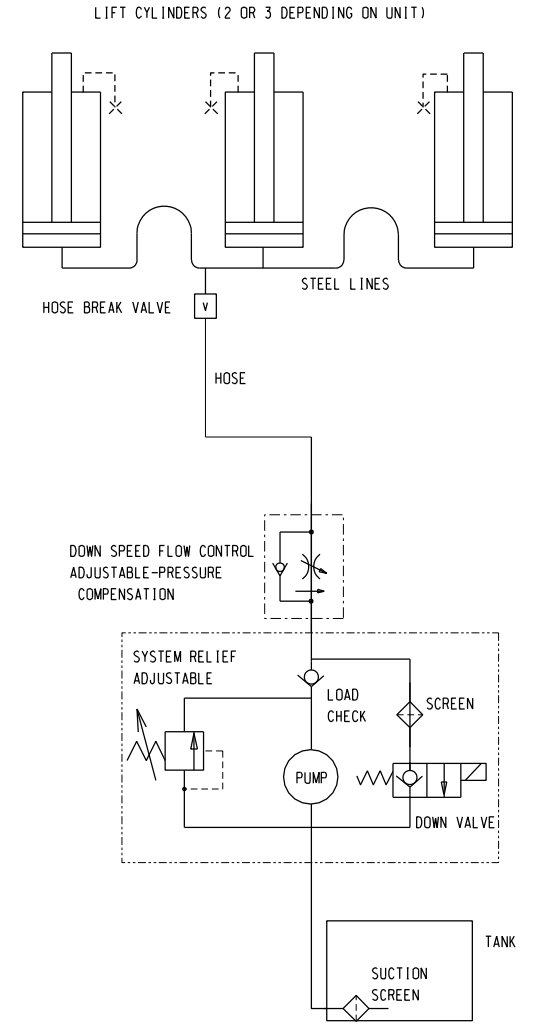

WIRING DIAGRAM

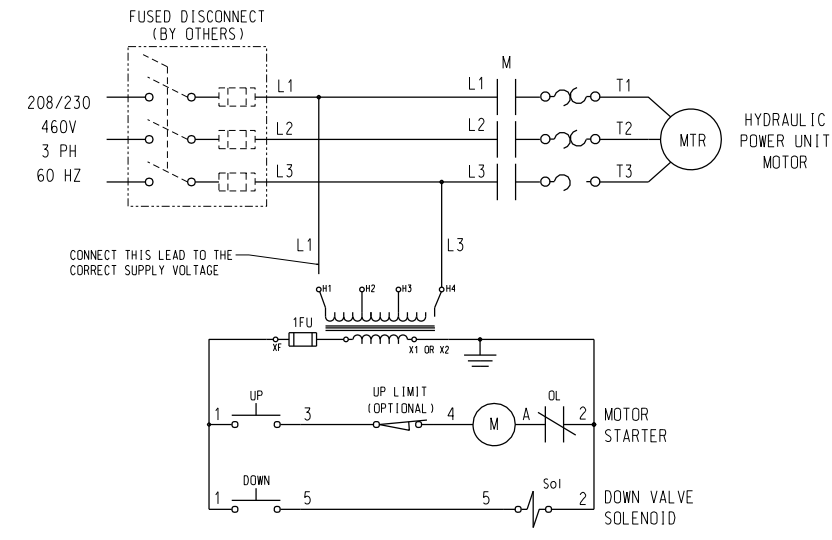

NOTE: UPPER TRAVEL LIMIT SWITCH IS OPTIONAL. IF LIMIT SWITCH IS ABSENT, MOVE WIRE 4 IN PANEL FROM TERMINAL 4 TO TERMINAL 3 AND RENUMBER AS WIRE 3.

BRIDGE NOTE:  
- 1 1/2" STEP REQUIRED FOR BRIDGE PLATE HINGE CLEARANCE  
- 4" STEP REQUIRED FOR ALUMINUM BRIDGE PLATE HINGE CLEARANCE

BRIDGE PLATE LENGTH AND WIDTH DIMENSIONS DETERMINE RECESS SIZE REQUIRED  
BRIDGE PLATE LENGTH + 1/2" AND BRIDGE PLATE WIDTH + 1 1/2"

NOTE:  
CONDUIT ENTRY CAN BE FROM ANY DIRECTION INCLUDING ENTRY FROM BOTTOM OF PIT SUMP.

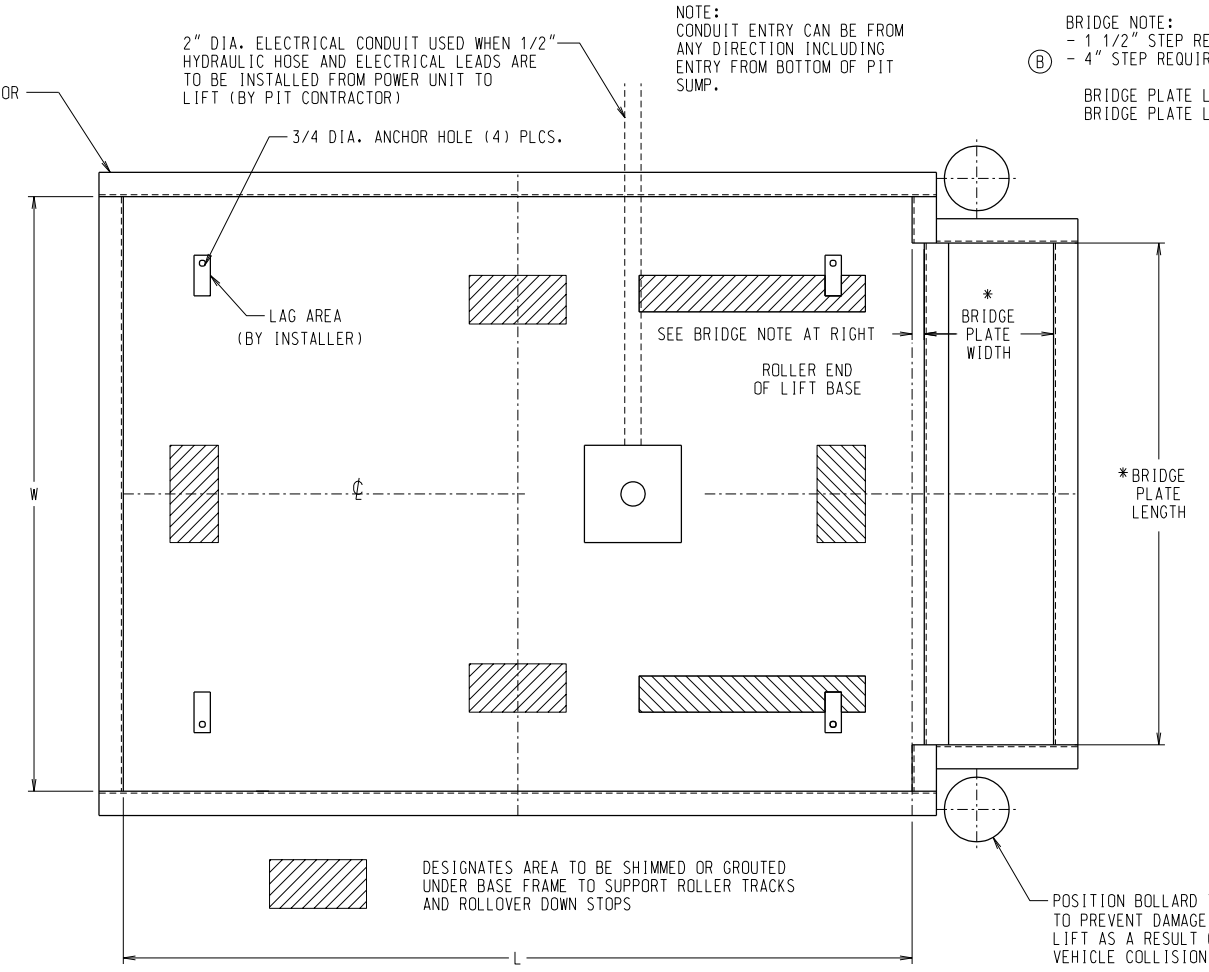

DOCK LIFT PLATFORM CHART FOR PIT PLAN

PLATFORM SIZE (FT)	W (INCHES)	L (INCHES)
6' X 8'	73 1/2	97 1/2
6' X 9'	73 1/2	109 1/2
6' X 10'	73 1/2	121 1/2
6' X 11'	73 1/2	133 1/2
6' X 12'	73 1/2	145 1/2
7' X 8'	85 1/2	97 1/2
7' X 9'	85 1/2	109 1/2
7' X 10'	85 1/2	121 1/2
7' X 11'	85 1/2	133 1/2
7' X 12'	85 1/2	145 1/2
8' X 8'	97 1/2	97 1/2
8' X 9'	97 1/2	109 1/2
8' X 10'	97 1/2	121 1/2
8' X 11'	97 1/2	133 1/2
8' X 12'	97 1/2	145 1/2

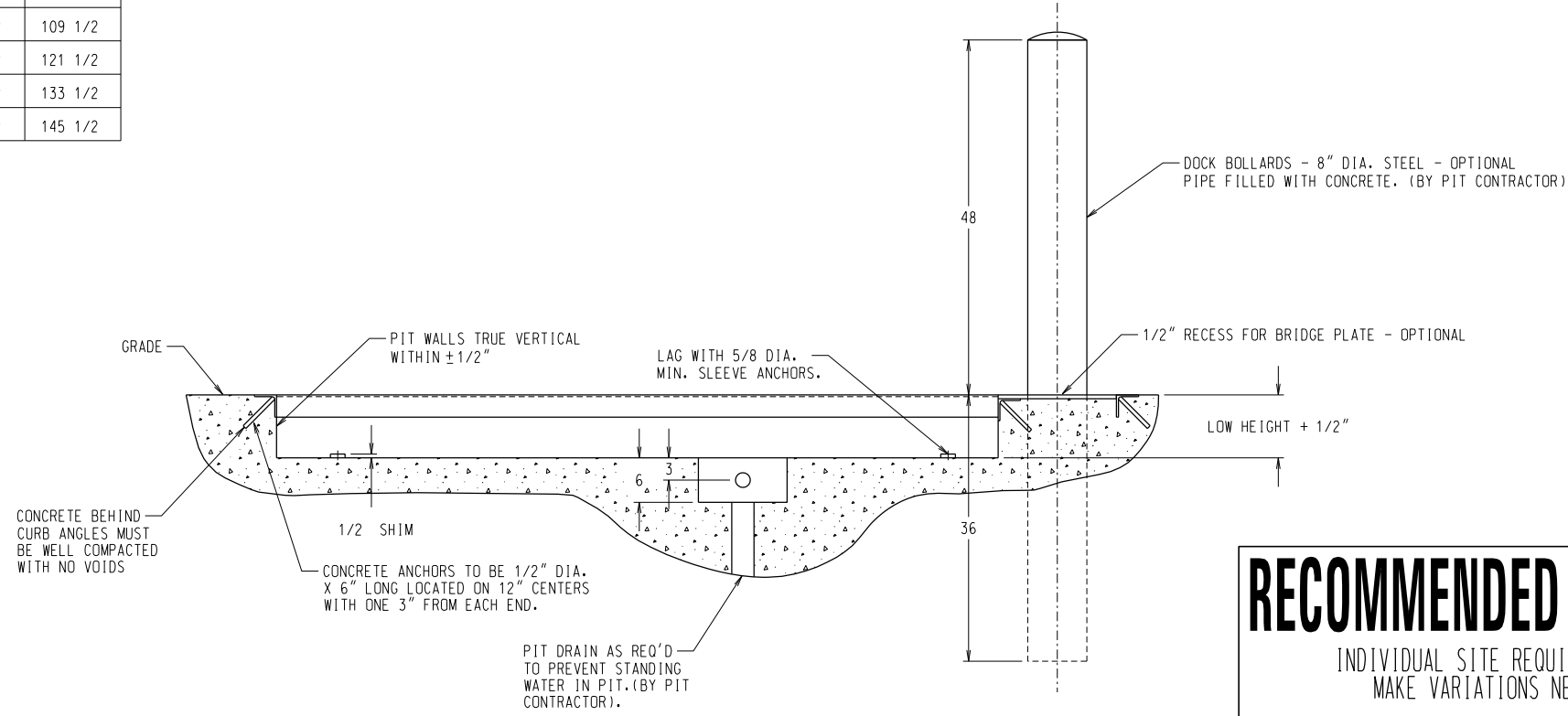

**RECOMMENDED PIT PLAN**  
INDIVIDUAL SITE REQUIREMENTS MAY MAKE VARIATIONS NECESSARY

**THIS DRAWING MUST BE AT REVISION: 'B'**

GENERAL NOTES:

- LIFT SHIPS WITH REMOVABLE LIFTING EYES INSTALLED.
- HYDRAULIC CONNECTION HOSE FROM LIFT TO POWER UNIT IS NOT INCLUDED UNLESS SPECIFIED.
- POWER UNIT BASIC DIMENSIONS - 23" L X 6" W X 14 3/4" H.
- HYDRAULIC FLUID INCLUDED AND SUPPLIED BY SOUTHWORTH.
- ELECTRICAL CONTROL PANEL IS PREWIRED AND MOUNTED TO POWER UNIT.
- HAND HELD PUSHBUTTON SUPPLIED WITH 20 FT COIL CORD PREWIRED TO CONTROL PANEL.

3RD ANGLE PROJECTION	FRACTIONS ±1/8 .XXX ±.005 .XX ±.01 ANGLES ±.5°	ITEM	QTY	DESCRIPTION PARTS LIST	PART NO.
	UNLESS OTHERWISE SPECIFIED, DIM ARE IN INCHES	SOUTHWORTH Southworth Products Corp. P.O. Box 1380 Portland, Maine 04104-1380			DR JCW DATE 2-21-11 CK DATE
USE OF PROPRIETARY INFORMATION LIMITED TO WRITTEN AGREEMENT	DDLS-59M	REFERENCE 60034744	CAGE CODE 06328	SCALE 1/12	FIG. NO. 60036949
	MODEL	TITLE	TT PIT PLAN DDLS-59M BS E	D	B