

SOUTHWORTH

OWNER'S MANUAL

For machines manufactured in 1994 and newer

Vertical Reciprocating Conveyor

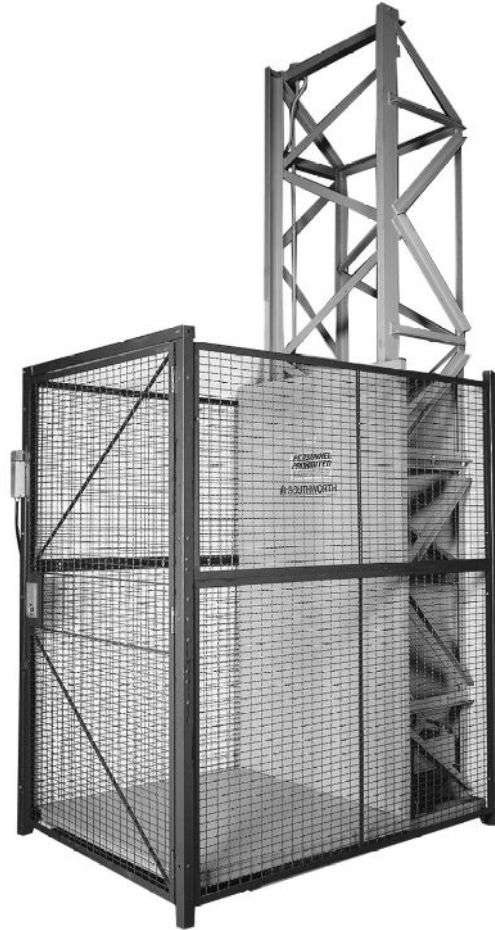

Model # _____

Serial # _____

Placed in Service _____

Southworth Products Corp

P.O. Box 1380, Portland, ME 04104-1380

Telephone (800) 743-1000 • (207) 878-0700 • Fax (207) 797-4734

www.SouthworthProducts.com

Email: service@SouthworthProducts.com

Please note: This manual was current at the time of printing.
To obtain the latest, most updated version, please contact Southworth's Customer Service Department or go to our website: www.SouthworthProducts.com,
under Parts & Service
you will find a complete list of current
owner's manuals to print.

CONTENTS

RESPONSIBILITY OF OWNERS AND USERS	Page 5
SAFETY ALERT SYMBOLS AND SIGNAL WORDS	6
SECTION 1 - OPERATION AND MAINTENANCE	7
INTRODUCTION	8
SAFETY	10
Operating the Southworth VRC Unit	11
Servicing the Southworth VRC Unit	12
OPERATING INSTRUCTIONS	13
Rules for Operation	13
Using the Southworth VRC Unit	19
Emergency Stop Function	19
Turning Off the Unit - End of Day	19
Lowering the Lift Platform with Power Off	19
MAINTENANCE PROCEDURES	20
Rules for Maintenance	20
Scheduled Maintenance	21
Inspecting the Brake Mechanism	22
Testing the Brake Mechanism	24
Replacing the Roller Assembly	24
Replacing the Lifting Chains	29
Adjusting the Lifting Chains	30
Replacing the Head Plate Load Rollers	30
Adjusting the Stabilization Chains	31
Replacing the Ram Gland Packing	32
Bleeding the Air from the System	32
Adjusting the Flow Control Valve	33
Adjusting the Relief Valve	34
Checking the Down Valve	35
Cleaning the Suction Strainer	35
Cleaning the Check Valve	37
TROUBLESHOOTING	37
Mechanical Problems	37
Electrical/ Hydraulic Problems	38
PARTS INFORMATION	41
Ordering Replacement Parts	41
SECTION 2 - INSTALLATION INSTRUCTIONS	Page 42
Before Beginning the Installation	42
Preparing the Unit	45
Temporary Hydraulic and Electrical Connections	46
Aligning the Unit	48
Main Power Connections	49
Hydraulic Connections	49
Installing the Pushbutton Stations	49
Installing the Gates and Interlocks	50
Adjusting the Limit Switches - Two-Level Unit	52
Adjusting the Limit Switches - Three-Level Unit	52
Adjusting the Stabilization Chains	54
Installing the Ram Stop and Pressure Switch	56
Testing	57
Completing the Installation	58
WARRANTY	Back Cover

LIST OF FIGURES

Fig. 1-1	Parts Identification, Single-Mast Unit	Page 7
Fig. 1-2	Ram Operating Principle	8
Fig. 1-3	Lift Operating Principle	9
Fig. 1-4	Hydraulic Diagram	10
Fig. 1-5	Close All of the Gates	11
Fig. 1-6	Do Not Ride on the Lift	12
Fig. 1-7	Load the Lift Correctly, Single-Mast Unit	14
Fig. 1-8	Labels - On Lift Platform	15
Fig. 1-9	Labels - On Frame and Power Unit	16
Fig. 1-10	Labels - On Gates	17
Fig. 1-10b	Levels - On Different Type Gates	18
Fig. 1-11	Unusual Link Bar Position Caused by Roller Wear	23
Fig. 1-12	Maintenance Points, Single-Mast Unit	25
Fig. 1-13	Brake Mechanism	26
Fig. 1-14	Roller Clearance	27
Fig. 1-15	Supporting the Front of the Table	28
Fig. 1-16	Inserting the Maintenance Devices	28
Fig. 1-17	Brake Link Pin Positions	29
Fig. 1-18	Roller Assembly	31
Fig. 1-19	Equalizing Head Plate Assembly	33
Fig. 1-20	Adjusting the Tension on the Stabilization Chains	35
Fig. 1-21	Repacking the Hydraulic Ram	36
Fig. 1-22	Type 1 (Standard) Power Unit	40
Fig. 1-23	Type 2 Power Unit	40
Fig. 2-1	Working Safely Under the Lift Platform	42
Fig. 2-2	Control Enclosures	43
Fig. 2-3	Leveling the Base Frame	45
Fig. 2-4	Bracing Single-Mast Unit (Back to Wall)	46
Fig. 2-5	Bracing Single-Mast Unit (Side to Wall)	47
Fig. 2-6	Checking the Mast for Plumb	48
Fig. 2-7	Pushbutton Station and Interlock Connections - Two-Level Unit	49
Fig. 2-8	Pushbutton Station and Interlock Connections - Three-Level Unit	50
Fig. 2-9	Interlock Unit	52
Fig. 2-10	Mounting the Interlocks	53
Fig. 2-11	Limit Switches, Two-Level Unit	54
Fig. 2-12	Limit Switches, Three-Level Unit	55
Fig. 2-13	Stabilization Chain Mechanism	56
Fig. 2-14	Initial Adjustment - Stabilization Chains	57
Fig. 2-15	Installing the Ram Stop Assembly	58
Fig. 2-16	Optional Pressure Switch	58

LIST OF TABLES

Table 1-1	Relief and Check Valve Locations	Page 8
Table 1-2	Scheduled Maintenance	21
Table 1-3	Hydraulic Oil Specifications	22
Table 1-4	Flow Control Locations	34
Table 1-5	Relief Valve Locations	34
Table 1-6	Down Valve Locations	36
Table 1-7	Strainer Locations	37
Table 1-8	Check Valve Locations	37
Table 2-1	Electrical Interface	44
Table 2-2	Hydraulic Oil Specifications	44
Table 2-3	Flow Control Locations	57

Responsibility of Owners and Users

Inspection and Maintenance

The device shall be inspected and maintained in proper working order in accordance with Southworth's owner's manual.

Removal from Service

Any device not in safe operating condition such as, but not limited to, excessive leakage, missing rollers, pins, or fasteners, any bent or cracked structural members, cut or frayed electric, hydraulic, or pneumatic lines, damaged or malfunctioning controls or safety devices, etc. shall be removed from service until it is repaired to the original manufacturer's standards.

Deflection

It is the responsibility of the user/purchaser to advise the manufacturer where deflection may be critical to the application.

Repairs

All repairs shall be made by qualified personnel in conformance with Southworth's instructions.

Operators

Only trained personnel and authorized personnel shall be permitted to operate the lift.

Before Operation

Before using the device, the operator shall have:

- Read and/or had explained, and understood, the manufacturer's operating instructions and safety rules.
- Inspected the device for proper operation and condition. Any suspect item shall be carefully examined and a determination made by a qualified person as to whether it constitutes a hazard. All items not in conformance with Southworth's specification shall be corrected before further use of the equipment.

During Operation

The device shall only be used in accordance with this owner's manual.

- Do not overload.
- Ensure that all safety devices are operational and in place.

Modifications or Alterations

Modifications or alterations to any Southworth industrial positioning equipment shall be made only with written permission from Southworth.

SAFETY ALERT SYMBOLS AND SIGNAL WORDS

The safety of all persons operating, maintaining, repairing, or in the vicinity of this equipment is of paramount concern. This is a powerful machine with moving parts, and is capable of causing personal injury if proper precautions are not taken. Therefore, throughout this manual, certain hazards have been identified which may occur in the use of the machine, and there are appropriate instructions or precautions which should be taken to avoid these hazards. In some cases, there are consequences which may occur if instructions or precautions are not followed. Below are the symbols and signal words along with their definitions referenced from ANSI Z535.4 - Product Safety Signs and Labels.

Safety Alert Symbols

These are the safety alert symbols.. They are used to alert you to potential physical injury hazards. Obey all safety messages that follow this symbol to avoid possible injury or death.



For use with **DANGER** signal word
(Red Background)



For use with **WARNING** signal word
(Orange Background)



For use with **CAUTION** signal word
(Yellow Background)

Signal Words

The meaning of different signal words as defined by ANSI Standard Z535.4 indicates the relative seriousness of the hazardous situation.



(Red Background)

DANGER indicates a hazardous situation which, if not avoided, will result in death or serious injury.



(Orange Background)

WARNING indicates a hazardous situation which, if not avoided, could result in death or serious injury.



(Yellow Background)

CAUTION, used with the safety alert symbol, indicates a hazardous situation which, if not avoided, could result in minor or moderate injury.



(Blue Background)

NOTICE is used to address practices not related to personal injury.



(Green Background)

SAFETY INSTRUCTIONS (or equivalent) signs indicate safety-related instructions or procedures.

Section 1: Operation and Maintenance

NOTE: This manual is arranged into two sections. Section 1 covers operation and maintenance. Everyone who uses or maintains the machine should read Section 1. Section 2 includes installation instructions. This section will be most useful to workers who will install the machine.

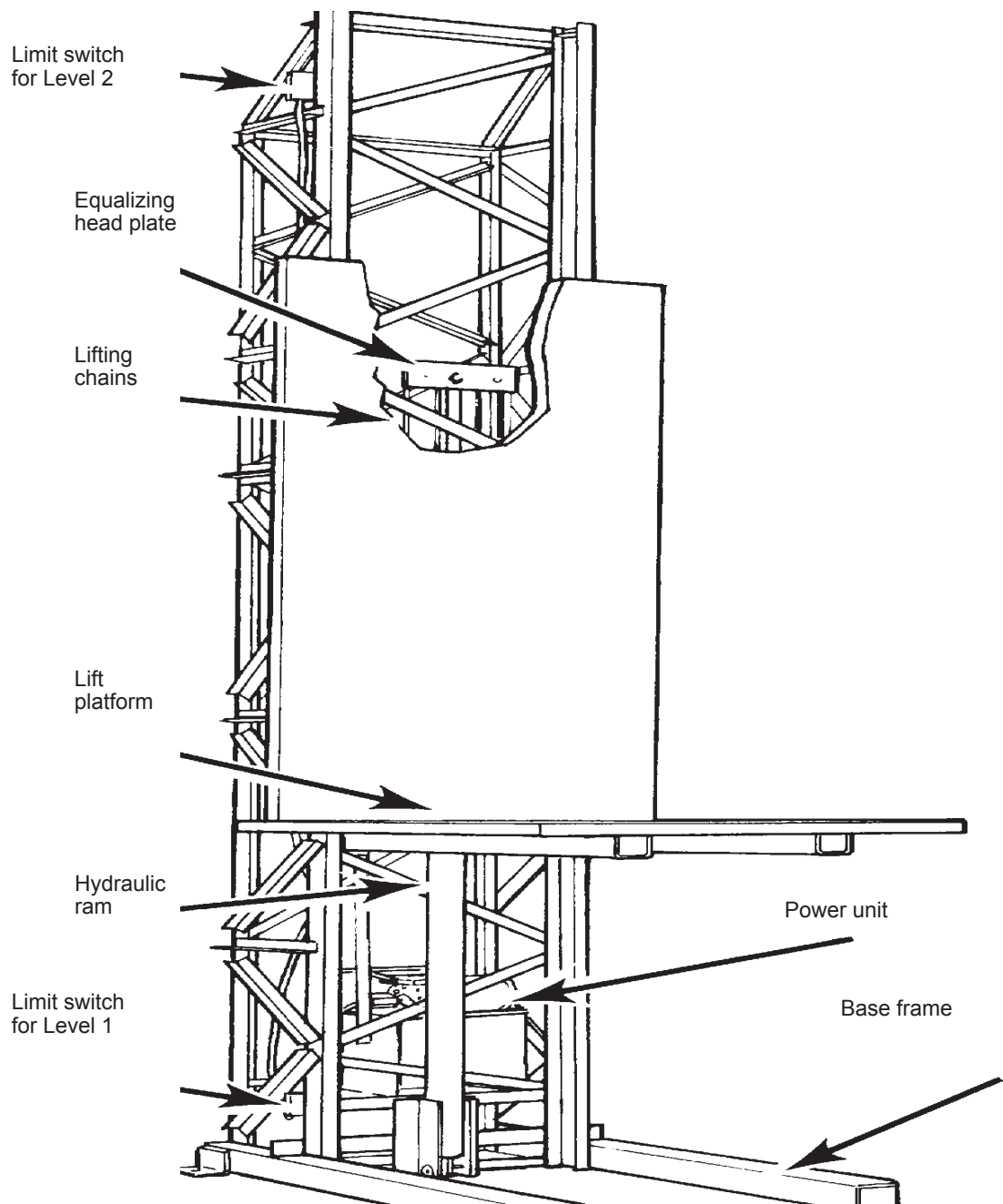

Fig. 1-1 – Parts Identification

Introduction

A Southworth Vertical Reciprocating Conveyor (or "VRC") makes it easy to move heavy loads from one floor level to another. In this manual, we will tell you how to install, operate and maintain a Southworth VRC. Figure 1-1 shows the important parts on a unit.

The lift mechanism uses a single-acting, positive-displacement hydraulic ram. Figure 1-2 shows how this type of cylinder operates. The hydraulic ram produces a smooth lifting action.

Figure 1-3 shows how the unit operates. The hydraulic ram raises the lift platform by acting on two lifting chains. One end of each chain is attached to the brake assembly

on the lift platform, and the other end is attached to the casing of the ram.

Each chain runs over one of the rollers on the equalizing head plate. As the ram extends, it raises the equalizing head plate, causing the lift platform to rise. This arrangement results in a 2:1 lifting ratio, so the rod travels just half as far as the lift platform.

Each VRC unit is supported by a vertical framework. For extra strength and stiffness, the framework uses a truss design.

Every Southworth VRC includes a number of features designed for long life and easy maintenance. Guide wheels are provided to keep the lift platform moving

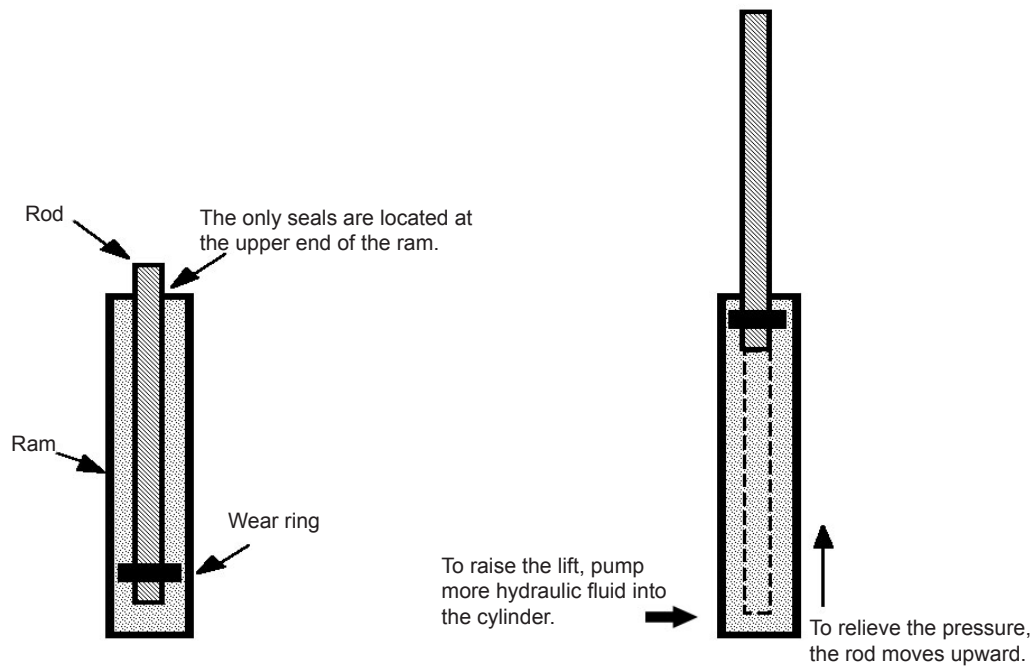

Fig. 1-2 – Ram Operating Principle

Type	Motor	Pump	Pressure relief and check valve location	See Fig.
Type 1 "standard"	3.2 hp	2.8 gpm	On pump	Fig. 1-25
Type 2	3.2 hp	3.9 gpm	Valve block	Fig. 1-26

Table 1-1 - Relief and Check Valve Locations

smoothly in the guide tracks. The wheel assemblies can be removed easily to simplify maintenance. On the hydraulic ram, the gland assembly may be completely removed. This makes it easier to repack the seals if they wear out. The rod may also be removed without dismounting the ram.

Figure 1-4 shows the hydraulic system on a typical Southworth VRC. The VRC may be fitted with one of three different power units.

The standard power unit includes a 3.2 hp motor and a 2.8 gpm gear pump. The solenoid-operated down valve, pressure relief valve and check valve are attached to the body of the gear pump. In this manual we will refer to this as a "Type 1" power unit. The "Type 2" unit also includes a 3.2 hp motor, but the pump is rated at 3.9 gpm. The lowering solenoid, pressure relief valve and

check valve are mounted in a separate valve block. The table below will help you to identify the two most common types of power units used on the VRC unit:

Power units rated for 5 hp, 7.5 hp and 10 hp are available to allow faster lifting speeds. These power units also use a horizontal arrangement, and include shafted TEFC motors with couplings and guards. These units also use the type of valve block previously described.

Southworth's product warranty is shown in the back of this manual. **THIS INSTRUCTION MANUAL IS NOT INTENDED TO BE OR TO CREATE ANY OTHER WARRANTY, EXPRESS OR IMPLIED, INCLUDING ANY IMPLIED WARRANTY OF MERCHANTABILITY OR FITNESS FOR A PARTICULAR PURPOSE, ALL OF WHICH ARE HEREBY EXPRESSLY EXCLUDED.**

A - Before Movement

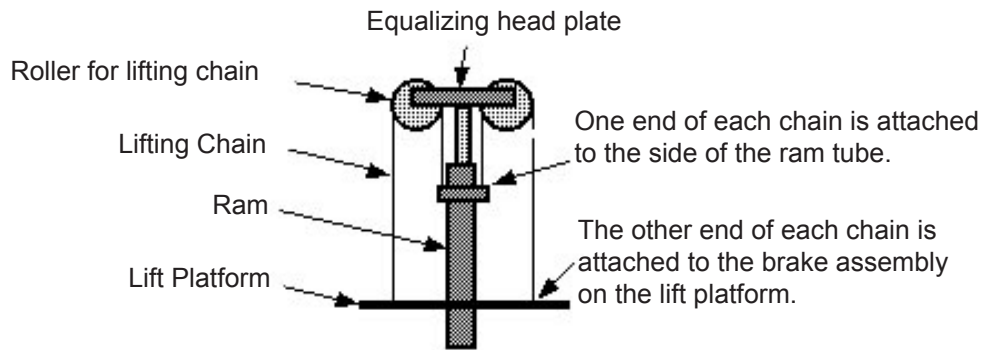

B - After Movement

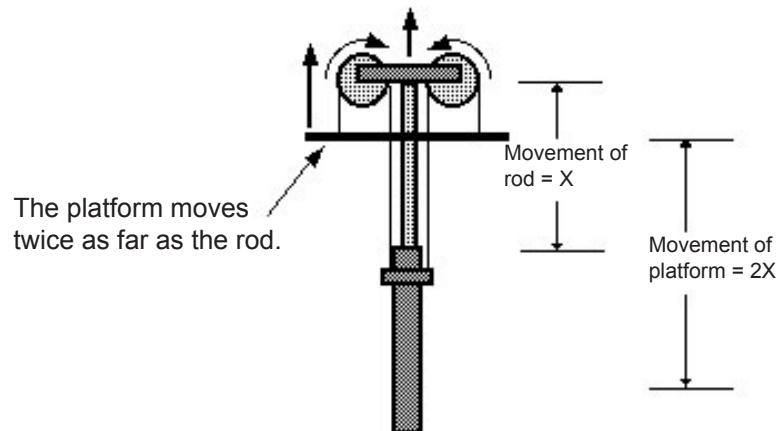

Fig. 1-3 – Lift Operating Principle

Vertical Reciprocating Conveyor

As set forth more specifically in the product warranty, Southworth's obligation under that warranty is limited to the repair or replacement of defective components, which shall be the buyer's sole remedy, and Southworth shall not be liable for any loss, injury, or damage to persons or property, nor for any direct, indirect, or consequential damage of any kind resulting from the Southworth VRC.

Safety

In general, Southworth is concerned about the safety of everyone who operates, maintains, repairs, or works near the Southworth VRC. It is a powerful machine with moving parts, and can cause serious personal injury if you do not take proper precautions.

Throughout this manual, we have included many safety precautions and warnings, and have pointed out some of the hazards which may occur as you use the machine. We have also listed the instructions or precautions you should take to avoid these hazards. In some

cases, we have also pointed out the consequences which may occur if you do not follow these instructions or precautions. On the product safety signs on this machine, the "signal words" are the words which indicate the degree of seriousness of possible hazards. The signal words on these product safety signs are DANGER, WARNING, and CAUTION:



DANGER Immediate hazard which will result in severe personal injury or death.



WARNING Hazard or unsafe practice which could result in severe personal injury or death.



CAUTION Hazard or unsafe practice which could result in minor personal injury or property damage.

In the interest of safety, please read this whole manual carefully. Please understand the material in this manual

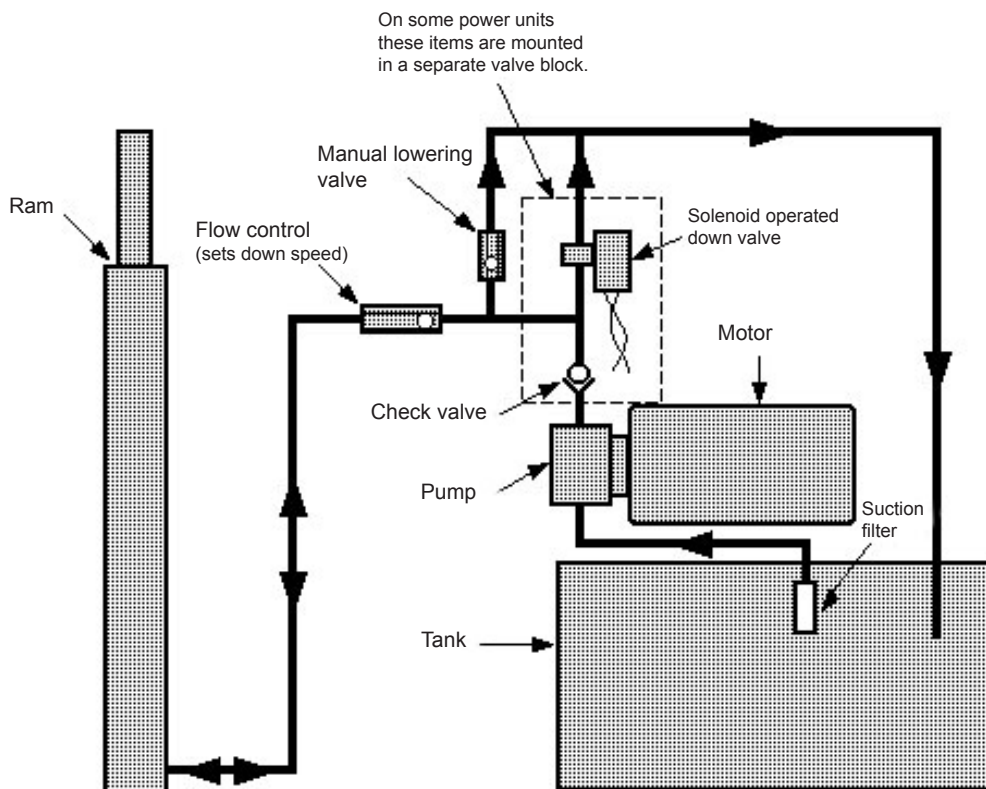

Fig. 1-4 – Hydraulic Diagram

before you install or use the Southworth VRC unit. Please follow all instructions and precautions in this manual completely.

Please be sure that everyone who uses or services the Southworth VRC has read and understood this manual. **Service and maintenance work should only be done by properly trained personnel.**

Southworth VRC lifts can be installed in a wide variety of industrial settings. The instructions included in this manual are not necessarily all-inclusive, because Southworth cannot anticipate all conceivable or unique situations. If you have questions about any of the instructions in this manual, please contact your dealer or Southworth Products Corporation.

Operating the Southworth VRC Unit

Please be sure that all persons operating the lift have been carefully trained to follow the operating procedures in this manual.

WARNING

Close all of the gates before you move the lift platform.

See Fig. 1-5. The unit should be fully enclosed, with a gate providing the only access at each level. Each gate should have an "interlock switch," as shown in the figure. Before the lift platform can move, all of the gates must be closed. All of the interlocks and gates must be installed before the unit is used in regular service. If the unit operates without the interlocks and gates installed, someone may fall into the space in which the lift operates. Someone may also be hit by the lift mechanism as it moves past an unprotected doorway. This could cause serious personal injury.

WARNING

Do not exceed the rated capacity of the lift.

Do not try to lift a load which exceeds the maximum rating for the unit. If you try this, the lift may fail suddenly. Someone may be hurt, and the lift and load may be damaged. The rated capacity for the unit is listed on a label on the lift platform.

WARNING

Never ride on the lift platform.

See Fig. 1-6. ASME standard #B20.1 is the applicable standard for vertical reciprocating conveyors. Section

5.12 states that, "No person shall ride a conveyor." Never allow anyone to ride on the Southworth VRC. Failure to comply with this instruction could result in serious personal injury. This vertical reciprocating conveyor, including the brake mechanism, is **not** designed to the same standards as a passenger elevator.

WARNING

Load the lift platform correctly.

On Southworth VRC units, place the load up against the back plate on the lift platform. See Fig. 1-7. Center the load side-to-side. Do not put a heavy load on the outer edge of the platform. This could create an eccentric loading condition for which the machine was not designed.

WARNING

Be sure the brake is working correctly.

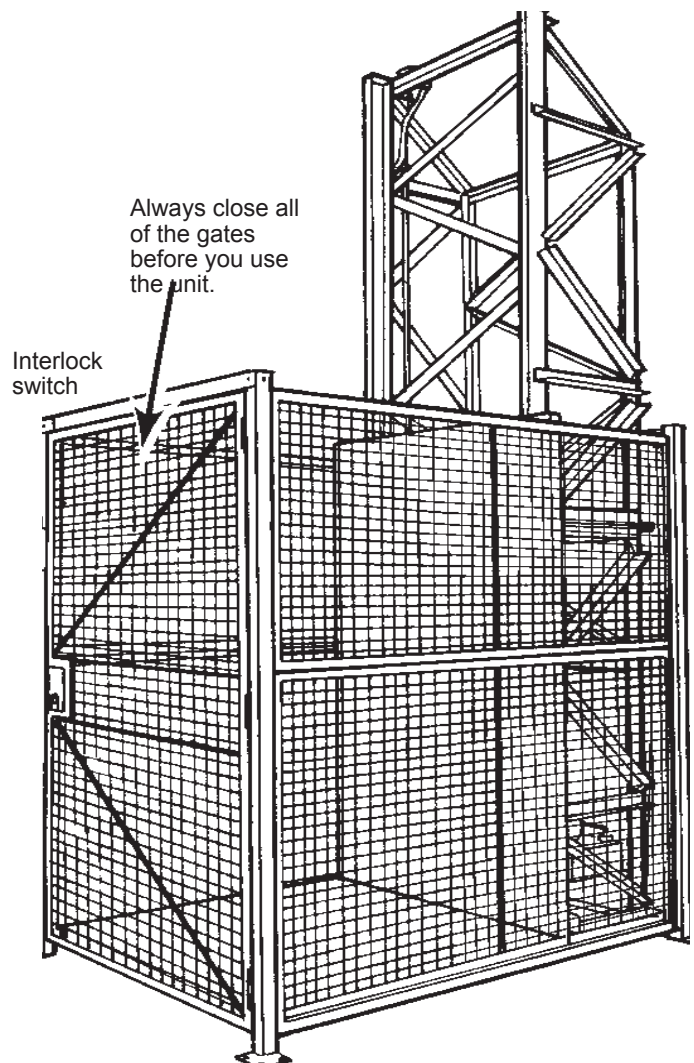

Fig. 1-5 – Close All of the Gates

Vertical Reciprocating Conveyor

The brake mechanism is designed to stop the lift platform from falling suddenly. This could happen if a lifting chain breaks or is slack. Figure 1-13 shows this assembly.

Here is how the mechanism works: On each side of the lift platform, the link bar is held in position by the lifting chain. If the lifting chain breaks, or becomes slack for any reason, the link bar will drop down. This will allow the spring to uncoil, rotating the shaft. This will cause the brake cam attached to the far end of the shaft to turn, and the teeth on the cam will grip the vertical track on the lift frame. This will stop the lift platform from dropping further. If properly maintained, the mechanism will work regardless of whether the platform is carrying a load.

The brake mechanism includes cams which bite firmly into the vertical tracks. Over time, the rollers on the lift platform may wear. The vertical tracks may also wear. Either kind of wear can impair the performance of the brake. You should be checking for this wear regularly. See the section on Maintenance Instructions. If you follow these instructions, you will spot this wear long before it can significantly affect the braking action. However, if the wear is allowed to continue, this can change the clearance between the brake cams and the vertical tracks. If this clearance is out of specification, the cams may not grip the vertical tracks, and the mechanism may not work. Failure to maintain the brake mechanism itself can also lead to a braking failure. **You can prevent any possible problem by checking the brakes, rollers, and tracks regularly, and replacing them if they are worn or otherwise impaired.**

Servicing the Southworth VRC Unit



Only authorized personnel should perform inspection or maintenance and service procedures. Unauthorized personnel attempting these procedures do so at the risk of personal injury or death.

Lower the Lift Platform

Before you begin to work on the unit, lower the lift platform completely. Once you have done this, the lift platform cannot drop suddenly. This is the safest way of working near the VRC unit, so you should lower the lift platform completely whenever you can.

Disconnect the Electric Supply



To avoid personal injury or death, turn off the

power and lock out the power at the primary power disconnect switch before service or maintenance per OSHA Lock-Out, Tag-Out procedures.

Be sure that nobody can start the VRC unit by accident. Whenever possible, turn off the main electrical disconnect before working on the machine. (Do this unless the maintenance procedure specifically requires that the unit have power.) Use a "lock out, tag out" procedure to prevent the switch from being turned on accidentally. To gain access through a locked gate, remove the interlock strike block. This should be done by qualified maintenance personnel only.

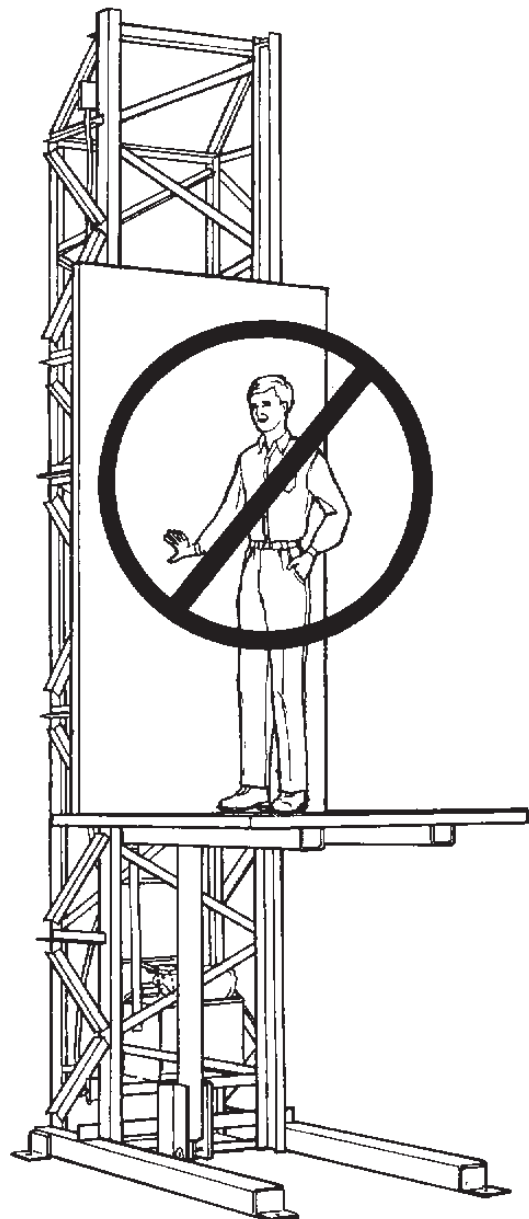

Fig. 1-6 – Do Not Ride on the Lift

Working Under the Lift Platform

⚠ DANGER

Never go under an unsupported platform! To avoid personal injury or death, always be sure the load has been removed from the platform and that it has been blocked adequately to prevent shifting or dropping unexpectedly!

To complete some maintenance jobs, you will have to work under the lift platform. Figure 1-18 shows the **only** safe way to do this. In the interest of safety, please follow **all** of these steps whenever you work under the lift:

- Before you work under the lift platform, make two maintenance devices. You will use these maintenance devices to support the lift platform while you are working under it. Cut two pieces of 4" x 4" lumber. (Hardwood or pine lumber will have sufficient strength.) Make them about 7 feet long so that you will have full headroom while working under the lift platform. Both devices should be the same length.
- When you are ready to work under the lift platform, remove any load from the platform.
- Raise the lift platform about 10 feet.
- Place each of the maintenance devices in position. Place the back of each device up against the vertical rail on the machine frame, as shown in Fig. 1-16. The bottom end of each device should rest on the floor. Using two clamps, hold each maintenance device in position so that it cannot move.

⚠ WARNING

As you insert or remove the maintenance devices, stand to the side of the lift. Do not stand under the lift platform. It is possible that the lift platform may drop suddenly, and you may be badly hurt. Do not stand under the lift platform until both of the maintenance devices are in place.

- Once the maintenance devices are in place, lower the lift platform so that it rests on the devices. Now the maintenance devices will prevent the lift from dropping suddenly.
- When you lower the platform onto the maintenance devices, this will also release the pressure in the hydraulic system. If you do not do this, pressure may remain in the hydraulic system.

⚠ WARNING

If you open a hydraulic fitting while the system is pressurized, the pressure may be released suddenly. You may be hurt by the released hydraulic oil, or by a part which is thrown outward by the pressure. If you release the pressure, and the lift platform is not resting on the maintenance devices, the platform may also drop suddenly. You may be badly hurt, or the lift may be damaged. To protect yourself, always follow the procedure we have described here. Be sure that nobody can start the VRC unit by accident. Always turn off the main electrical disconnect before working with the hydraulic system.

- Finish working under the lift platform. Turn the electrical supply back on, then raise the lift platform and remove the maintenance devices.
- Go through all of these steps every time you must work under the lift platform. Do this even if you will only be under the platform for a moment!

Operating Instructions

Please be sure that all persons operating the lift have been carefully trained to follow the operating procedures in this manual.

Rules for Operation

Please read the whole section on "Safety Instructions" before you operate the unit. The VRC unit has been designed to be as safe as possible for the operator. However, the unit is a powerful piece of machinery. You can be badly hurt if you bypass the interlock switches or break some of the other rules. Please check the following points.

⚠ WARNING

Close all of the gates before you move the lift platform. See Fig. 1-5. The unit should be fully enclosed, with a gate providing the only access at each level. Each gate should have an "interlock switch," as shown in the figure. Before the lift platform can move, all of the gates must be closed. All of the interlocks and gates must be installed before the unit is used in regular service. If the unit operates without the interlocks and gates

Vertical Reciprocating Conveyor

installed, someone may fall into the space in which the lift operates. Someone may also be hit by the lift mechanism as it moves past an unprotected doorway. This could cause serious personal injury.

WARNING

Do not exceed the rated capacity of the lift. Do not try to lift a load which exceeds the maximum rating for the unit. If you try this, the lift may fail suddenly. Someone may be hurt, and the lift and load may be damaged. The rated capacity for the unit is listed on a label on the lift platform.

WARNING

Never ride on the lift platform. See Fig. 1-6. ASME standard #B20.1 is the applicable standard for vertical reciprocating conveyors. Section 5.12 states that, "No person shall ride a conveyor." Never allow anyone to ride on the Southworth VRC. Failure to comply with this instruction could result in serious personal injury. This vertical reciprocating conveyor, including the brake mechanism, is not designed to the same standards as a passenger elevator.

WARNING

Load the lift platform correctly. On Southworth VRC units with one mast, place the load up against the back plate on the lift platform. See Fig. 1-7. Center the load side-to-side. Do not put a heavy load on the outer edge of the platform. This could create an eccentric loading condition for which the machine was not designed.

On a unit with two masts, place the load in the center of the lift platform. Center the load side-to-side. This could create an eccentric loading condition for which the machine was not designed.

WARNING

Be sure the brake mechanism is working correctly. The brake mechanism is designed to stop the lift platform from falling suddenly. This could happen if a lifting chain breaks or is slack. Figure 1-13 shows this assembly.

Fig. 1-7 – Load the Lift Correctly

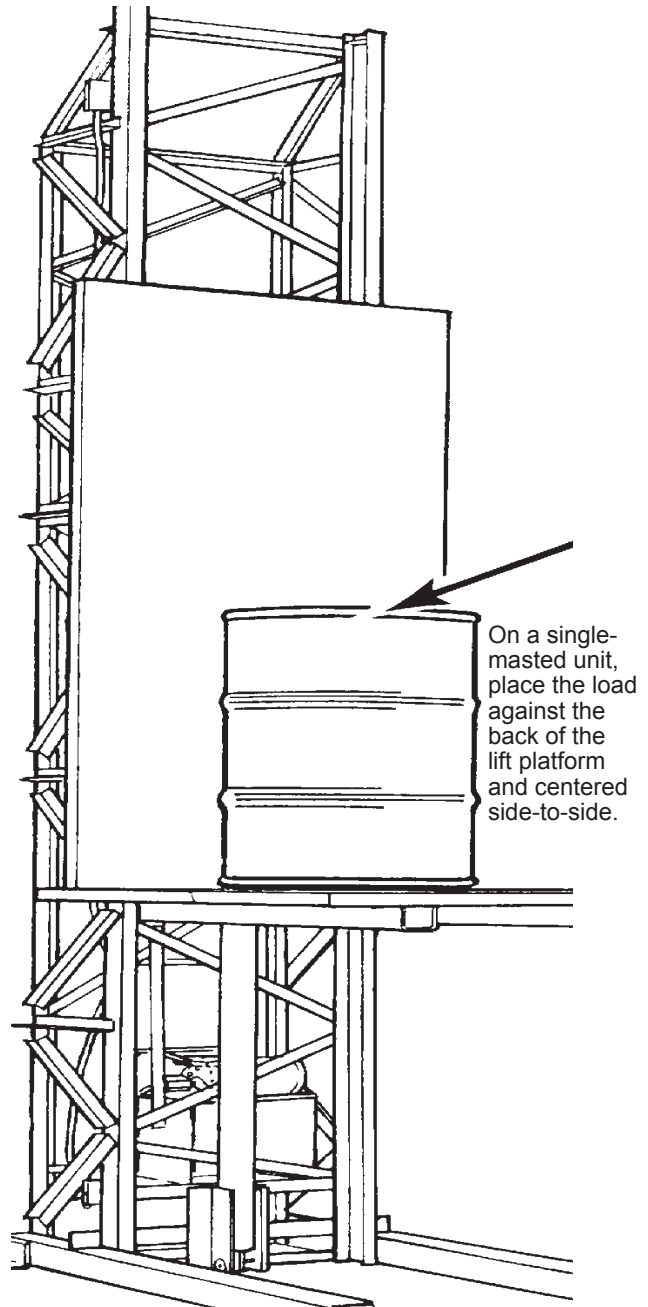

Check the warning labels.

Figures 1-8 through 1-10b show the warning labels which have been attached to the machine. These labels are included for your safety – be sure they are always in place. Do not paint over any labels. If one of the labels becomes damaged or torn, get a replacement from Southworth.

Fig. 1-8 – VRC Labels on Lift Platform
Important!

The part number is located on the lower right hand side of each label. Make sure surface is free of dirt and oil before applying self-adhering labels. Clean surface with soap and water or acetone if necessary before applying self-adhering labels. Please contact the customer service department at 1-800-743-1000 with any questions.

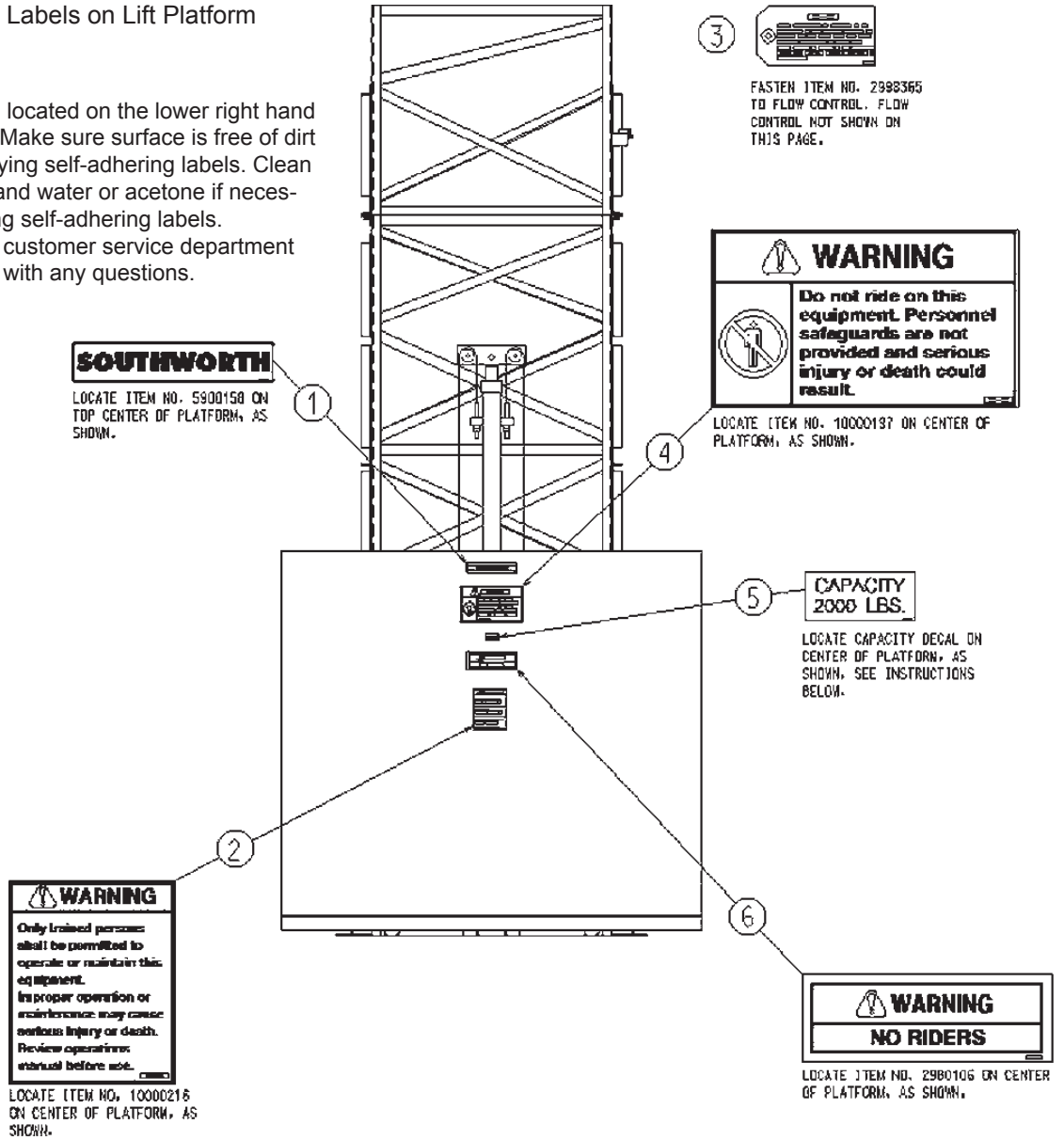

Item	Part#	Location
1	5900158	Locate on top center of platform, as shown.
2	10000216	Locate on center of platform, as shown.
3	2998365	Fasten to flow control. Flow control not shown.
4	10000197	Locate on center of platform, as shown.
5	Capacity Decals	
	Item no.	Capacity
	2998433	500#
	2998425	1000#
	2998434	1500#
	2998427	2000#
	2998435	2500#
	2998436	3000#
	2998437	3500#
	2998426	4000#
	Locate capacity decal specific to machine on center of platform, as shown.	
6	2980106	Locate on center of platform, as shown.

Vertical Reciprocating Conveyor

Fig. 1-9— VRC Labels on Frame and Power Unit

Important!

The part number is located on the lower right hand side of each label. Make sure surface is free of dirt and oil before applying self-adhering labels. Clean surface with soap and water or acetone if necessary before applying self-adhering labels. Please contact the Customer Service Department at 1-800-743-1000 with any questions.

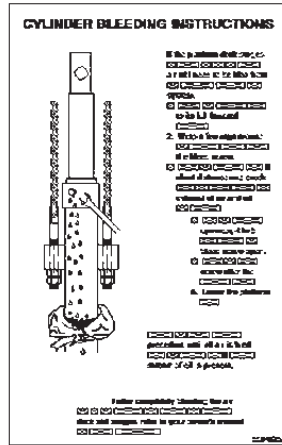

LOCATE ITEM NO. 5904615 ON RAM UNDER THE CHAIN ATTACHING BLOCK.

NOTICE: DO NOT EXHAUST LIFT TO FULL UPPER POSITIVE STOP. UPPER TRAVEL LIMIT SWITCH MUST BE CONNECTED TO PREVENT POSSIBLE STRUCTURAL DAMAGE. CHECK OPERATION OF UP LIMIT SWITCH AND ADJUST AS NECESSARY.

LOCATE ITEM NO. 2921026 ON OUTSIDE OF CONTROL PANEL AS SHOWN.

VIEW DETAIL A:A BELOW FOR LAYOUT OF DECALS ON HYDRAULIC POWER UNIT.

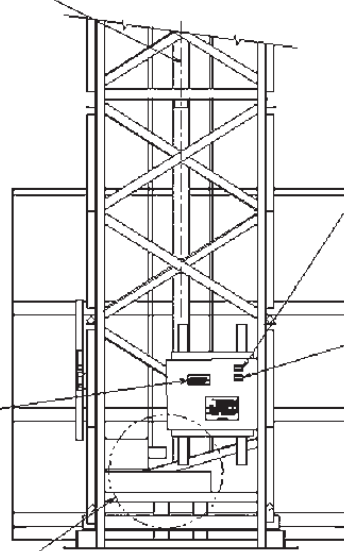

LOCATE POWER DECAL ON BOTH INSIDE AND OUTSIDE OF CONTROL PANEL. SEE INSTRUCTIONS BELOW.

LOCATE CONTROL DECAL ON BOTH INSIDE AND OUTSIDE OF CONTROL PANEL. SEE INSTRUCTIONS BELOW.

TANK TO BE FULL ONLY WHEN CYLINDER IS COLLAPSED.

LOCATE ITEM NO. 2986997 ON POWER UNIT AS SHOWN.

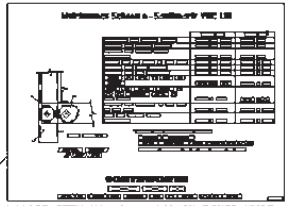

LOCATE ITEM NO. 10000149 ON POWER UNIT AS SHOWN.

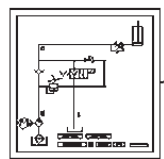

LOCATE ITEM NO. 5900754 ON POWER UNIT AS SHOWN.

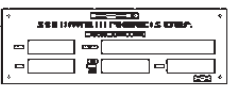

LOCATE ITEM NO. 2986968 ON POWER UNIT AS SHOWN.

Item	Part#	Location
7	5904615	Locate on ram under the chain attaching block.
8	2921026	Locate on outside of control panel as shown.
9	2986997	Locate on power unit as shown.
10	5900754	Locate on power unit as shown.
11	Power Decals	
	Item no.	Voltage
	2987000	115/1/60
	5900160	230/1/60
	2987001	208/3/60
	2987002	230/3/60
	Item no.	Voltage
	2987003	460/3/60
	5900162	575/3/60
	5900163	110/1/50
	5900164	220/1/50
	Item no.	Voltage
	2999416	380/3/50
	5900165	415/3/50
	2991783	12 VDC
	5900161	24 VDC
12	Locate one power decal specific to machine both inside and outside of control panel, as shown.	
	Control Decals	
	Item no.	Voltage
	2986999	115/1/60
	2986998	24/1/60
	Item no.	Voltage
	5900166	24 VDC
	5900167	110/1/50
	Locate control decal specific to machine on both inside and outside of control panel, as shown.	
13	10000149	Locate on power unit as shown.
14	2986968	Locate on power unit as shown.

Fig. 1-10 – VRC Label Location On Gates

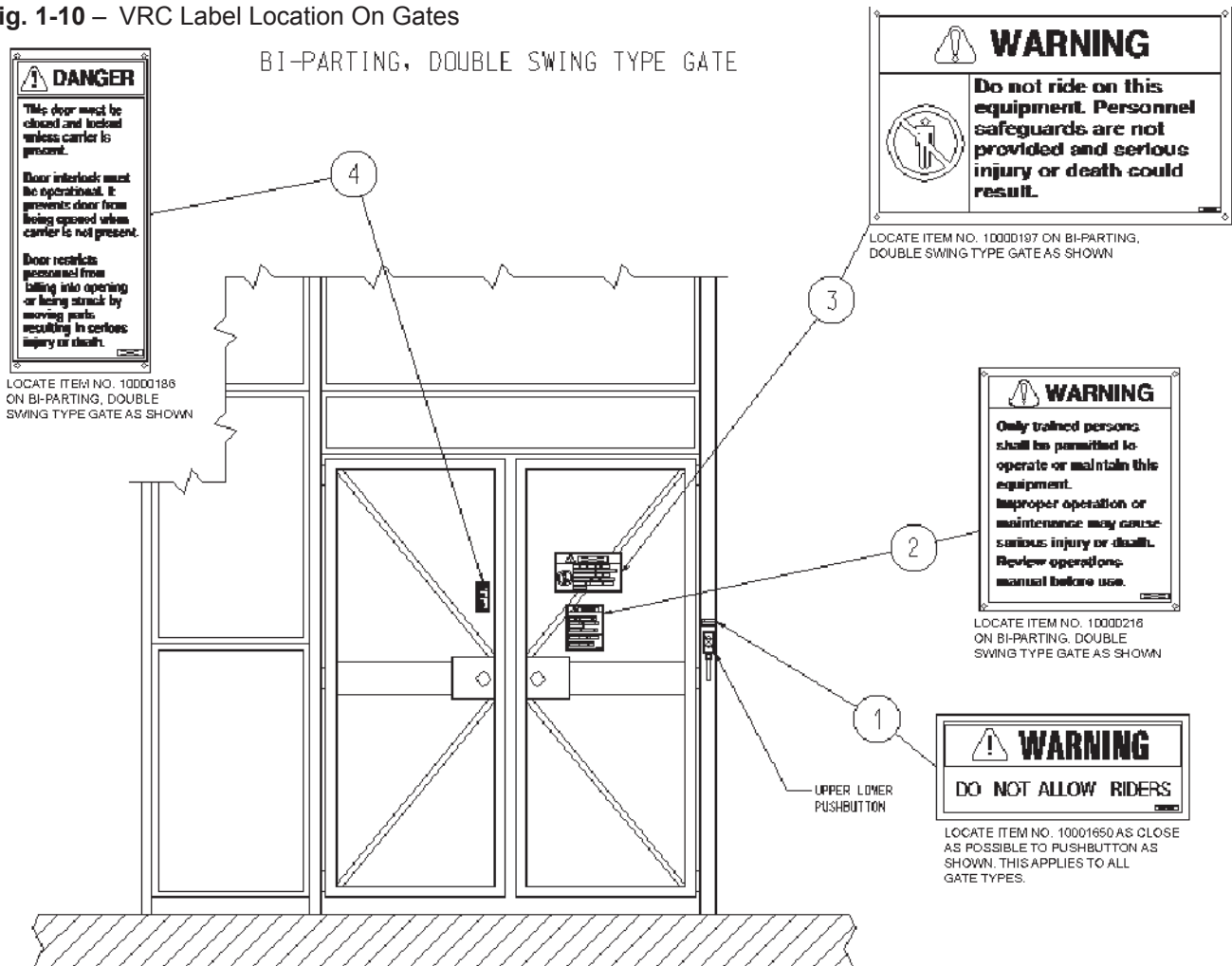

IMPORTANT!

- 1) IT IS THE RESPONSIBILITY OF THE INSTALLER TO AFFIX ALL PRECAUTIONARY LABELING WHICH IS PROVIDED WITH SOUTHWORTH VRC'S. SHOULD YOU HAVE ANY QUESTIONS PLEASE CALL 1-800-743-1000.
- 2) THERE SHOULD BE (1) ONE LABEL KIT FOR EACH GATE TO BE INSTALLED.
- 3) LOCATE LABELS ON GATES AS SHOWN ABOVE.
- 4) IF YOUR GATE IS DIFFERENT FROM THE BI-PARTING DOUBLE SWING TYPE GATE EXAMPLE ABOVE, REFER TO PICTURES ON THE NEXT PAGE FOR THE GATE WHICH MOST RESEMBLES YOUR TYPE GATE.
- 5) PLACE EACH LABEL WHERE THE NUMBERED BALLOON INDICATES AT EYE LEVEL WHERE IT CAN EASILY BE SEEN.
- 6) LABELS SHOULD BE AFFIXED IN A PERMANENT MANNER WHEN ATTACHED TO WIRE MESH. INSTALLER WILL NEED TO PROVIDE A SMOOTH FLAT SURFACE (IE SHEET METAL OR PLASTIC) FOR THE LABELS TO BE APPLIED TO. THESE FLAT SURFACES SHOULD BE BOLTED OR WIRED THROUGH THE MESH. MAKE SURE ALL SURFACES ARE CLEAN AND DRY WITH NO GREASE PRESENT BEFORE APPLYING THE ADHESIVE-BACKED LABELS.

Important!

The part number is located on the lower right hand side of each label. Make sure surface is free of dirt and oil before applying self-adhering labels. Clean surface with soap and water or acetone if necessary before applying self-adhering labels. Non-self adhering labels should be affixed in a permanent manner. When attached to wire mesh they should be bolted or wired through the mesh. Please contact the customer service department at 1-800-743-1000 with any questions.

Item	Part#	Location
1	10001850	Locate as close as possible to pushbutton as shown. This applies to all gate types.
2	10000216	Locate on bi-parting, double swing type gates as shown.
3	10000197	Locate on bi-parting, double swing type gates as shown.
4	10000186	Locate on bi-parting, double swing type gates as shown.

Vertical Reciprocating Conveyor

Fig. 1-10b –
VRC Labels
Location On
Different
Type Gates

Important!

The part number is located on the lower right hand side of each label. Make sure surface is free of dirt and oil before applying self-adhering labels. Clean surface with soap and water or acetone if necessary before applying self-adhering labels. Non-self adhering labels should be affixed in a permanent manner. When attached to wire mesh they should be bolted or wired through the mesh. Please contact the customer service department at 1-800-743-1000 with any questions.

DOUBLE PANEL, VERTICAL RISING TYPE GATE

10000186

10000197 (3)

10000216 (2)

1
LOCATE ITEM NO. 10001850 AS CLOSE AS POSSIBLE TO PUSHBUTTON AS SHOWN.

SINGLE PANEL, VERTICAL RISING TYPE GATE

10000197 (3)

10000186 (4)

10000216 (2)

1
LOCATE ITEM NO. 10001850 AS CLOSE AS POSSIBLE TO PUSHBUTTON AS SHOWN.

SINGLE SWING TYPE GATE (GATE SHOWN PARTIALLY OPEN)

10000197 (3)

10000216 (2)

1
LOCATE ITEM NO. 10001850 AS CLOSE AS POSSIBLE TO PUSHBUTTON AS SHOWN.

ROLL-UP TYPE DOOR

10000197 (3)

10000186 (4)

10000216 (2)

1
LOCATE ITEM NO. 10001850 AS CLOSE AS POSSIBLE TO PUSHBUTTON AS SHOWN.

LOCATE ITEMS NO. 2, 3, AND 4 ON HALL AS CLOSE AS POSSIBLE TO ROLL-UP DOOR AS SHOWN.

HORIZONTAL SLIDING TYPE GATE (GATE SHOWN PARTIALLY OPEN)

10000186 (4)

10000197 (3)

10000216 (2)

1
LOCATE ITEM NO. 10001850 AS CLOSE AS POSSIBLE TO PUSHBUTTON AS SHOWN.

IMPORTANT!

- 1) IT IS THE RESPONSIBILITY OF THE INSTALLER TO AFFIX ALL PRECAUTIONARY LABELING WHICH IS PROVIDED WITH SOUTHWORTH VRC'S. SHOULD YOU HAVE ANY QUESTIONS PLEASE CALL 1-800-743-1000.
- 2) THERE SHOULD BE (1) ONE LABEL KIT FOR EACH GATE TO BE INSTALLED.
- 3) LOCATE LABELS ON GATES AS SHOWN ABOVE.
- 4) PLACE EACH LABEL WHERE THE NUMBERED BALLOON INDICATES AT EYE LEVEL, WHERE IT CAN EASILY BE SEEN.
- 5) LABELS SHOULD BE AFFIXED IN A PERMANENT MANNER WHEN ATTACHED TO THE WIRE MESH. INSTALLER WILL NEED TO PROVIDE A SMOOTH FLAT SURFACE (IE. SHEET METAL OR PLASTIC) FOR THE LABELS TO BE APPLIED TO. THESE FLAT SURFACES SHOULD BE BOLTED OR WIRED THROUGH THE MESH. MAKE SURE ALL SURFACES ARE CLEAN AND DRY WITH NO GREASE PRESENT BEFORE APPLYING THE ADHESIVE-BACKED LABELS.

Item	Part#	Location
1	10001850	Locate as close as possible to pushbutton as shown. This applies to all gate types.
2	10000216	Refer to pictures above for the gate which most resembles your type gate. Locate as shown.
3	10000197	Refer to pictures above for the gate which most resembles your type gate. Locate as shown.
4	10000186	Refer to pictures above for the gate which most resembles your type gate. Locate as shown.

Using the Southworth VRC Unit

Please review the safety notes we have listed:

To start the VRC unit turn on the power at the main disconnect. This switch is usually mounted away from the control cabinet on the unit.

All of the gates must be closed before the lift platform will move.

Two kinds of controls are used on different versions of this lift:

“Maintained contact”: Once you press a control button, the control will continue to operate until the lift arrives at a stopping point. To stop the lift before a stopping point, you can press the E-Stop button.

“Momentary contact”: Each control will only operate as long as you are pressing the button. As soon as you release the button, the lift will stop.

To raise or lower a two-level unit:

- For a unit with maintained contact controls:
 - Press the Up or Down button. The lift will stop when it arrives at the next level.
- For a unit with momentary contact controls:
 - Press and hold the Up or Down button. The lift will stop when you release the button, or when it reaches the next floor level.

To raise or lower a unit with three or more levels:

- For a unit with maintained contact controls:
 - Press the control button for the level to which you want to send the lift. The lift will stop when it arrives at the next level.
- For a unit with momentary contact controls:
 - Press and hold the Up or Down button. The lift will stop when you release the button, or when it reaches the next floor level. To move to another floor level in the same direction, press and hold the button again.

⚠ CAUTION

The details of the operation sequence depend on the way your installation is wired. The operating sequence at your installation may be different.

⚠ CAUTION

If your unit is supplied with a standard TENV motor, it is rated for intermittent use – a maximum of 15 minutes per hour. Do not operate the unit continuously. This may cause the motor to overheat and burn out. If this happens, the machine will not operate.

Emergency Stop Function

On an installation with maintained-contact controls, there is an E-Stop switch on the control box at each floor level. In an emergency, you can stop the lift platform by using any of the E-Stop switches. To stop the platform, press the switch in. All of the E-Stop switches must be pulled out again before the platform will move.

Turning Off the Unit – End of Day

At the end of the day, always lower the lift platform to the lowest level. Do not leave the lift platform in a raised position.

Turn off the power at the main disconnect.

Lowering the Lift Platform with Power Off

You can lower the lift platform, even if the power is turned off. This may be helpful during a power failure. Before you do this, unload the lift platform if possible. Be sure everyone is clear of the lift platform.

⚠ WARNING

The interlocks will not work when the power is turned off. This means the lift platform can be lowered, even though one of the gates is open. Be careful to warn everyone near the unit and make sure everyone is clear before you lower the lift platform.

The manual lowering valve is located on one of the hydraulic lines which run between the tank and the hose to the ram. See Fig. 1-22 or 1-23. To lower the platform, turn the adjusting knob counterclockwise. Be sure to close the valve when you are finished. To do this, turn the knob clockwise as far as it will go.

Vertical Reciprocating Conveyor Maintenance Procedures

⚠️ WARNING

Only authorized personnel should perform inspection or maintenance and service procedures. Unauthorized personnel attempting these procedures do so at the risk of personal injury or death.

⚠️ DANGER

Failure to properly adhere to lift blocking procedures is to risk the sudden and uncontrolled descent of the lift during maintenance or inspection. A falling lift can cause severe injury or death.

This procedure describes the only factory-approved method of working under a lift. Follow these instructions EVERY time you plan to reach or enter bodily beneath the lift to perform service or maintenance - no matter how momentary that might be.

If the maintenance device(s) are damaged or missing, stop immediately and contact the factory for assistance. The manufacturer can not foresee, and is not liable for, failure to use the approved maintenance device(s) and procedures that have been provided.

Rules for Maintenance

Lowering the Lift Platform to Preferred Maintenance Level

The safest way to inspect or maintain a VRC unit is with the load removed and the lift carriage in the fully lowered position. When the carriage is fully lowered it has no potential to suddenly or unexpectedly shift or drop.

If the lift carriage cannot be lowered normally, contact the factory for assistance. If stalled or stuck, the carriage should be secured at its stuck position before attempting to walk on or under the platform.

⚠️ DANGER

Never go under an unsupported platform! To avoid personal injury or death, always be sure the load has been removed from the platform and that it has been blocked adequately to prevent shifting or dropping unexpectedly!

Please read the whole section on "Safety Instructions" before you maintain the unit. The VRC unit has been designed to be as safe as possible for the maintenance worker. However, the unit is a powerful piece of machinery. You can be badly hurt if you bypass the

interlock switches or break some of the other rules. Please check the following points.

Before you begin to work on the unit, lower the lift platform completely. Once you have done this, the lift platform cannot drop suddenly. This is the safest way of working near the VRC unit, so you should lower the lift platform completely whenever you can.

Be sure that nobody can start the VRC unit by accident. Whenever possible, turn off the main electrical disconnect before working on the machine. (Do this unless the maintenance procedure specifically requires that the unit have power.) Use a "lock out, tag out" procedure to prevent the switch from being turned on accidentally. To gain access through a locked gate, remove the interlock strike block. This should be done by qualified maintenance personnel only.

To complete some maintenance jobs, you will have to work under the lift platform. Figure 1-16 shows the only safe way to do this. In the interest of safety, please follow all of these steps whenever you work under the lift:

- Before you work under the lift platform, make two maintenance devices. You will use these maintenance devices to support the lift platform while you are working under it. Cut two pieces of 4" x 4" lumber. (Hardwood or pine lumber will have sufficient strength.) Make them about 7 feet long so that you will have full headroom while working under the lift platform. Both devices should be the same length.
- When you are ready to work under the lift platform, remove any load from the platform.
- Raise the lift platform about 10 feet.
- Place each of the maintenance devices in position. Place the back of each device up against the vertical rail on the machine frame, as shown in Fig. 1-16. The bottom end of each device should rest on the floor. Using two clamps, hold each maintenance device in position so that it cannot move.

⚠️ WARNING

As you insert or remove the maintenance devices, stand to the side of the lift. Do not stand under the lift platform. It is possible that the lift platform may drop suddenly, and you may be badly hurt. Do not stand under the lift platform until both of the maintenance devices are in place.

- Once the maintenance devices are in place, lower

the lift platform so that it rests on the devices. Now the maintenance devices will prevent the lift from dropping suddenly.

- When you lower the platform onto the maintenance devices, this will also release the pressure in the hydraulic system. If you do not do this, pressure may remain in the hydraulic system.

⚠ WARNING

If you open a hydraulic fitting while the system is pressurized, the pressure may be released suddenly. You may be hurt by the released hydraulic oil, or by a part which is thrown outward by the pressure. If you release the pressure, and the lift platform is not resting on the maintenance devices, the platform may also drop suddenly. You may be badly hurt, or the lift may be damaged. To protect yourself, always follow the procedure we have described here. Be sure that nobody can start the VRC unit by accident. Always turn off the main electrical disconnect before working with the hydraulic system.

- Finish working under the lift platform. Turn the electrical supply back on, then raise the lift platform

and remove the maintenance devices.

- Go through all of these steps every time you must work under the lift platform. Do this even if you will only be under the platform for a moment!

Scheduled Maintenance

See the table below for a summary of the regular maintenance which should be performed on the VRC unit. The table also lists the frequency of the maintenance procedures, based on the conditions in which the machine is used. Southworth has provided a copy of this table, which should be attached to the tank on the hydraulic power unit. For detailed maintenance instructions, see the following sections. Figure 1-12 shows the maintenance points.

Lubricating the Lifting Chains

Brush all parts of the chains with 30 W or heavier motor oil. Do this every week if the Southworth VRC is used in a corrosive environment.

Inspecting the Lifting Chains

The chains should be free of rust or corrosion. Run the lift platform up and down, and check the action of each chain as the links move over the load rollers.

Regular Maintenance Job	Frequency - General Duty	Frequency - Severe Duty*
Lubricate the lifting chains	Every 1-2 months	Every week
Inspect the lifting chains	Every 1-2 months	Every month
Inspect the brake mechanism	Every 1-2 months	Every month
Check the oil level in the tank	Every 1-2 months	Every 2 weeks
Inspect the mast frames	Every 1-2 months	Every 2 weeks
Inspect the lift platform	Every 1-2 months	Every 2 weeks
Grease the inside of each vertical track	Every 1-2 months	Every 2 weeks
Check for smooth motion as the lift platform moves up and down	Every 1-2 months	Every 2 weeks
Inspect the packing at the top of the ram	Every 6 months	Every 3 months
Test the brake mechanism	Every year	Every 6 months

Table 1-2 - Maintenance Schedule

*Severe duty applications include any of the following conditions:

- Corrosive environments
- Extreme temperatures (below 32°F or above 120°F)
- Frequent operation (30 or more cycles per day)

Vertical Reciprocating Conveyor

CAUTION

Stand clear of the lifting mechanism as you check the chains. Do not allow any clothing to become caught in the mechanism.

Each chain should move freely, without any sign of binding. Check the links carefully for damaged plates, pins or rollers. If the space around the unit is very dusty or dirty, clean the chains by wiping down each chain with a rag dipped in solvent. Finally, brush all parts of the chains with 30W or heavier motor oil.

Checking the Oil Level in the Tank

When the lift platform is lowered, the oil should be about $\frac{3}{4}$ inch below the top of the tank. If the level is low, add some hydraulic oil. Table 1-3 lists the specifications for the oil. If the oil level continues to drop over a period of time, check the system for an oil leak.

Inspecting the Mast Frames

The vertical tracks should be free of dirt or foreign materials. There should not be any metal-to-metal rubbing between the mast(s) and the platform carriage. Check the anchor bolts at the base of the unit. Check the welds on the parts of the mast.

Inspecting the Lift Platform

Check for loose hardware. Each of the guide wheels should be able to turn freely. The surface of each guide wheel should be smooth, and not show any signs of flaking. Try to move each wheel from side to side on its axle. You should not feel any clearance or “play” in the wheel bearings. If the bearings feel “gritty” or loose, they should be replaced. See the section on “Replacing the Roller Bearings.” (The bearings are sealed, and cannot be lubricated.)

Lubricating the Vertical Tracks

The vertical guides are located on the supporting masts, as shown in Fig. 1-12. As the lift platform rises and falls, the guide wheels roll up and down these vertical tracks. Coat the inside of each vertical track with axle grease. This will help the lift platform to move smoothly.

Type	Manufacturer
Conoco Super 32	Conoco
D.T.E. 24	Mobil Oil Corporation
NUTO H32	Exxon Corporation
Amoco AW32	Amoco Corporation

Table 1-3 – Hydraulic Oil Specifications

Inspecting the Ram Packing

Check for smooth motion as the lift platform moves up and down. Inspect the packing at the top of the ram. We’ve shown this part in Fig. 1-21. If you see more than a trace of oil here, the packing is beginning to leak, and should be replaced. See the section on “Replacing the Packing.”

Inspecting the Brake Mechanism

You should do this inspection at least every 2 months (1 month for severe-duty service). Also check the brake mechanism after each time the brakes operate. If you do not do this, the brake cams may begin to drag, increasing the chances that the brakes will engage.

Figure 1-13 shows the brake mechanism. To check this mechanism, start by unloading the lift platform.

Raise the lift platform to a height where you can check the lower rollers easily. On each side, check the clearance between the cam and the track, as shown in Fig. 1-14. Be careful not to put any part of your body under the lift platform as you do this.

WARNING

If the clearance on either side is smaller than the specification, this indicates excessive wear on the lower roller and/or track. Stop using the lift and replace the rollers immediately. Excessive wear can cause the brake mechanism to fail.

Raise the lift platform, and rest the outer end on a strong support, as shown in Fig. 1-15. Lower the lift platform so that the outer end is supported. On each side, check the clearance between the cam and the track, as shown in Fig. 1-14. Be careful not to put any part of your body under the lift platform as you do this.

WARNING

In this case, if the clearance on either side is larger than the specification, this indicates excessive wear on the lower roller and/or track. Stop using the lift and replace the rollers immediately.

Replace the rollers as required in paragraphs 2 or 3, and re-check the dimensions in accordance with both paragraphs. (For instructions, see the material on “Replacing the Roller Assembly” in this section.) If the dimensions are within specifications, you may continue to use the machine. If the dimensions are still too large, the tracks should be repaired or replaced. Contact Southworth for instructions.

Raise the lift platform, and insert the maintenance devices, as shown in Fig. 1-16.

Lower the lift platform carefully until it rests on the maintenance devices. Lower the platform a bit more until it stops. At this point the lifting chains should be slack. On each brake mechanism, the link bar should move downward. See Fig. 1-17. Each of the brake cams should rotate until it comes into contact with the track.

Turn off the main disconnect switch. Use the “lock-out, tag-out” procedure to keep anyone from starting the unit by accident.

Inspect each mechanism and each of the brake cams for signs of damage. Be sure the teeth on each cam are sharp, and have not been worn off. The brake cams should be free of grease, oil, or hydraulic fluid. Also check the rest of each mechanism for any loose or missing pieces. Clean away any dirt or corrosion on the parts. Be sure to clean the spaces between the teeth of the cams.

⚠️WARNING

If the brake cams do not rotate freely to contact the track frame, do not perform the drop-test described in the next section.

Move each assembly by hand. Lubricate all moving parts with machine oil or graphite. Do not lubricate the teeth on the brake cams. This would prevent them from gripping the rails.

Inspect the vertical rails. The rails may be damaged if the brake mechanism operates repeatedly on the same sections.

Turn on the power again. Raise the lift platform and remove the maintenance devices.

When the machine is operating normally, the brake mechanism will reset when the lift platform first moves upward. After you check the brake mechanism as described here, it is important to see that both brakes have reset. On each side, the link bar should be raised into the normal working position shown in Fig. 1-17.

If the rollers are worn, one of the link bars may be allowed to swing into or hang in the position shown in Fig. 1-11. This will prevent one of the brake mechanisms from resetting.

⚠️CAUTION

If one of the brakes does not reset, and you operate the lift, the brake may drag as the lift platform moves upward. This can cause the cams and vertical tracks to wear quickly. When you try to lower the lift, the worn tracks may cause the brake to engage, and the platform may be caught at the top of the lift. Do not operate the lift unless the brake mechanism is working correctly.

To reset one of the brake mechanisms, insert the maintenance devices as shown in Fig. 1-16. Go to the rear of the lift and work from inside the frame of the tower. *Never stand under the lift platform as you reset the brakes.* Force the link bar forward, toward the front of the lift, as shown in Fig. 1-11.

⚠️CAUTION

The link bar and lifting arm will snap into position, and may make a loud noise.

If the roller clearances are too great, or if the brake mechanisms are damaged, stop using the lift. The brakes may not operate if needed. Do not use the lift again until it has been repaired.

Replace the rollers, and check the clearances again.

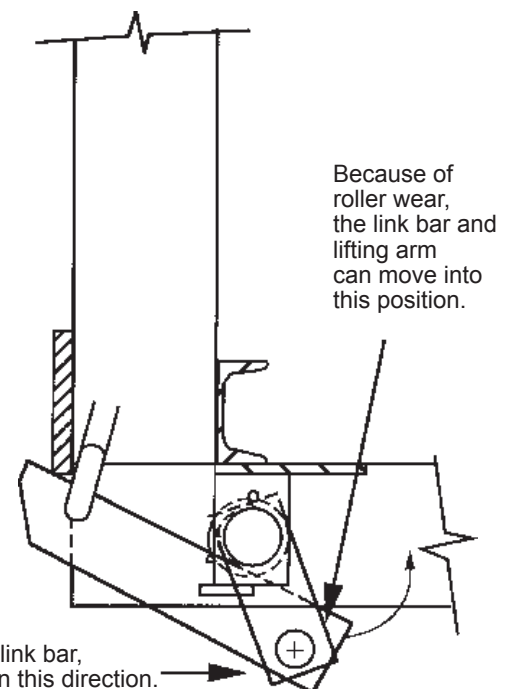

Fig. 1-11– Unusual Link Bar Position Caused by Roller Wear

Vertical Reciprocating Conveyor

Testing the Brake Mechanism

Note: You should do this test at least once a year. Perform the test every 6 months if the unit is used in a “severe duty” application. The unit faces severe duty if it is used in a corrosive environment, extreme temperatures, or operated more than 30 times a day. **Also do this test after each time the brakes engage.**

Before doing this test, inspect the brake mechanism. See the instructions in the last section. Be sure that both brakes have reset. See Step 12 in the last section. If necessary, reset both mechanisms using force.

This test should be performed with the lift platform **at its rated load capacity**. Each time you do this test, set the lift platform at a different height on the machine. This will prevent excessive wear on any one section of the vertical rails.

Place an adequate support (wood 4x4 or equivalent) under the front of the lift platform. See Fig. 1-15. (Each time you perform this test, use a support with a different length. If you are using a support made of wood, you can cut off about 5” after each test.)

Remove all tools and other objects from the space under the lift platform. Be sure that nobody is standing under the lift platform.

Lower the lift platform just enough so the chains are slack. The rear end of the lift platform should settle, and there should be about 6” of slack. Double-check that the brake cams on the brake mechanisms have rotated onto the tracks.

Carefully pull the support out of the space under the platform. Be careful to pull the support **away** from the lift. To pull the support, use a rope or chain which is long enough so that you do not have to stand under the lift platform. Pull with a fork-lift or a come-along, if necessary.

⚠WARNING

Do not stand under the lift platform as you do this. If the brake mechanism is not working properly, the lift platform may drop suddenly. The falling platform could cause serious injury or even death to a person underneath.

If the brake mechanism is working correctly, the platform will drop approximately 1”, then stop. The braking cams should engage right away.

If the brake mechanism does not stop the platform within 1” to 3”, then replace the platform rollers and retest. If any of the parts are worn, call the factory and order replacements.

If, after you replace the rollers, the brake mechanism still does not stop the platform, some of the brake parts should be replaced. Contact Southworth for instructions.

To release the brake mechanism, jog the hydraulic cylinder up slowly until the cams snap free. After this test, it is important to see that both brake mechanisms have reset. On each side, the link bar should be raised into the normal working position shown in Fig. 1-17.

If the rollers are worn, one of the link bars may be allowed to swing into the position shown in Fig. 1-11. This will prevent one of the brake mechanisms from resetting.

If one of the brake mechanisms does not reset, and you operate the lift, the brake may drag as the lift platform moves upward. When you try to lower the lift, the brake may engage, and the platform may be caught at the top of the lift.

Set the maintenance devices under the lift platform as show in Fig. 1-16. Turn off the main disconnect switch. Lock out and tag the switch. This will prevent someone else from starting the VRC unit by accident.

To reset one of the brake mechanisms, go to the rear of the lift. Work from inside the frame of the tower. **Never stand under the lift platform as you reset the brakes.** Force the link bar forward, toward the front of the lift.

⚠CAUTION

The link bar and lifting arm will snap into position, and may make a loud noise.

Replacing the Roller Assembly

1. The guide wheels are designed to allow the lift platform to move up and down smoothly. Each wheel assembly can be replaced easily if it wears out. See Fig. 1-18.
2. In each vertical track, about 5½’ above ground level, you will find a 1¾” diameter hole. Raise the platform until the axles are opposite the holes in the vertical tracks.
3. Set the maintenance devices under the lift platform as shown in Fig. 1-16. Turn off the main disconnect switch. Lock out and tag the switch. This will prevent someone else from starting the VRC unit by accident.
4. Expand the retaining ring at the end of the axle, and remove the ring.
5. Find the set screw, located in the set collar at the other end of the axle. Turn this screw out to release the set collar.

Single mast, overall view:

If the lift has stabilization chains, the upper chain rollers will be installed here.

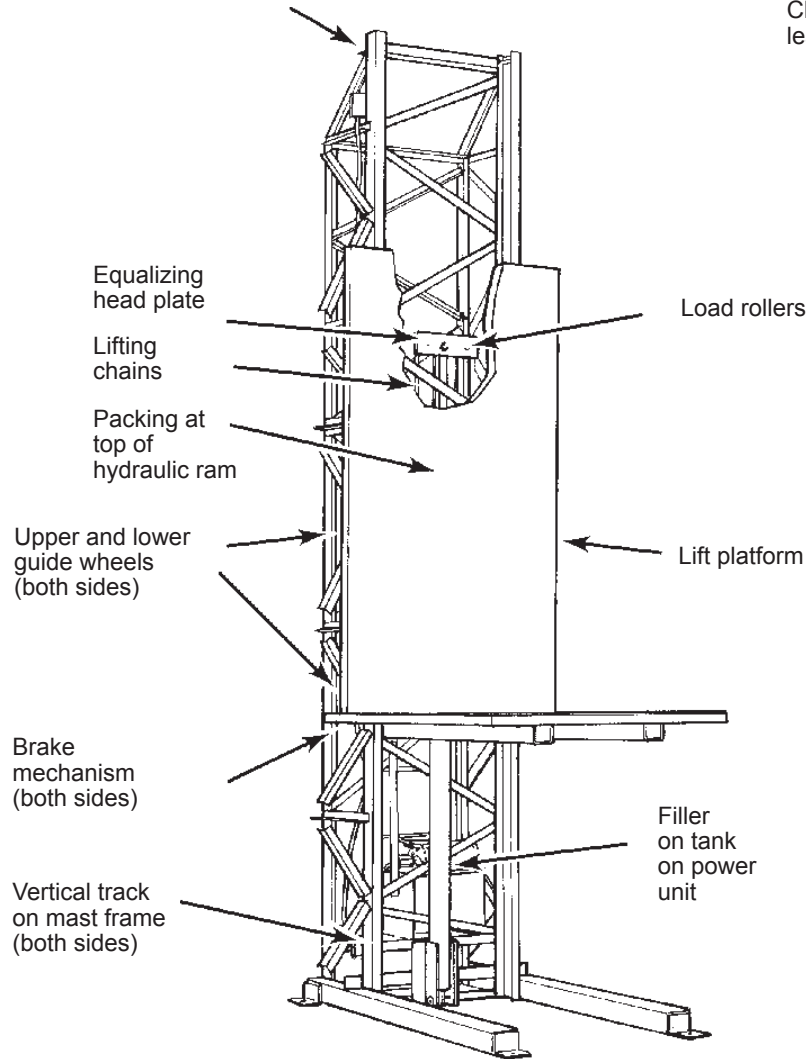

Top of hydraulic ram:

Check for leaks here

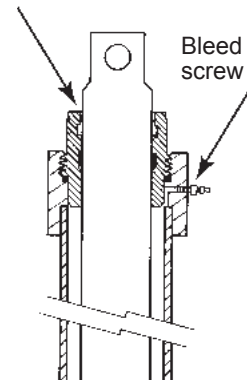

Hydraulic power unit (Type 1):

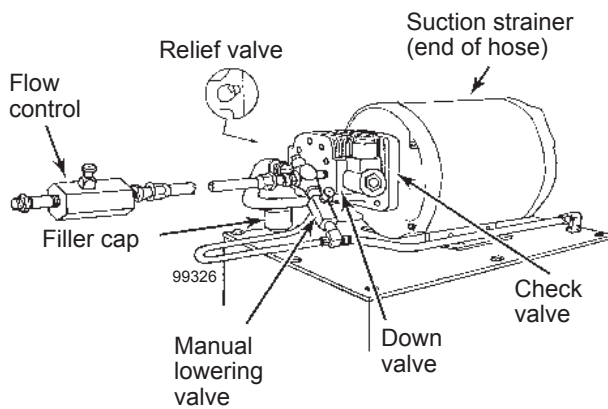

Hydraulic power unit (Type 2):

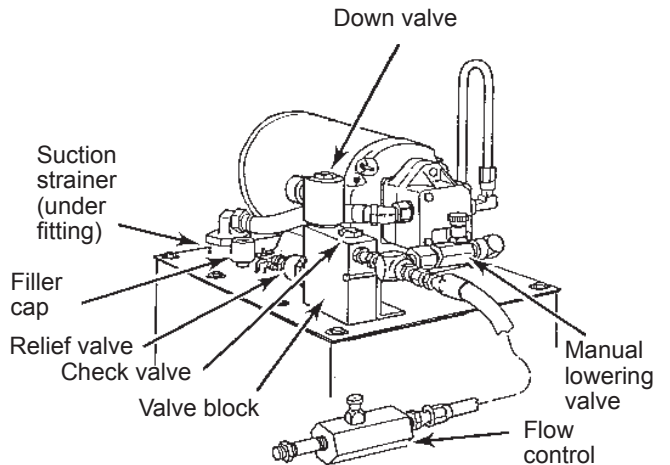

Fig. 1-12 – Maintenance Points, Single-Mast Unit

Vertical Reciprocating Conveyor

Link bar on right side,
viewed from rear:

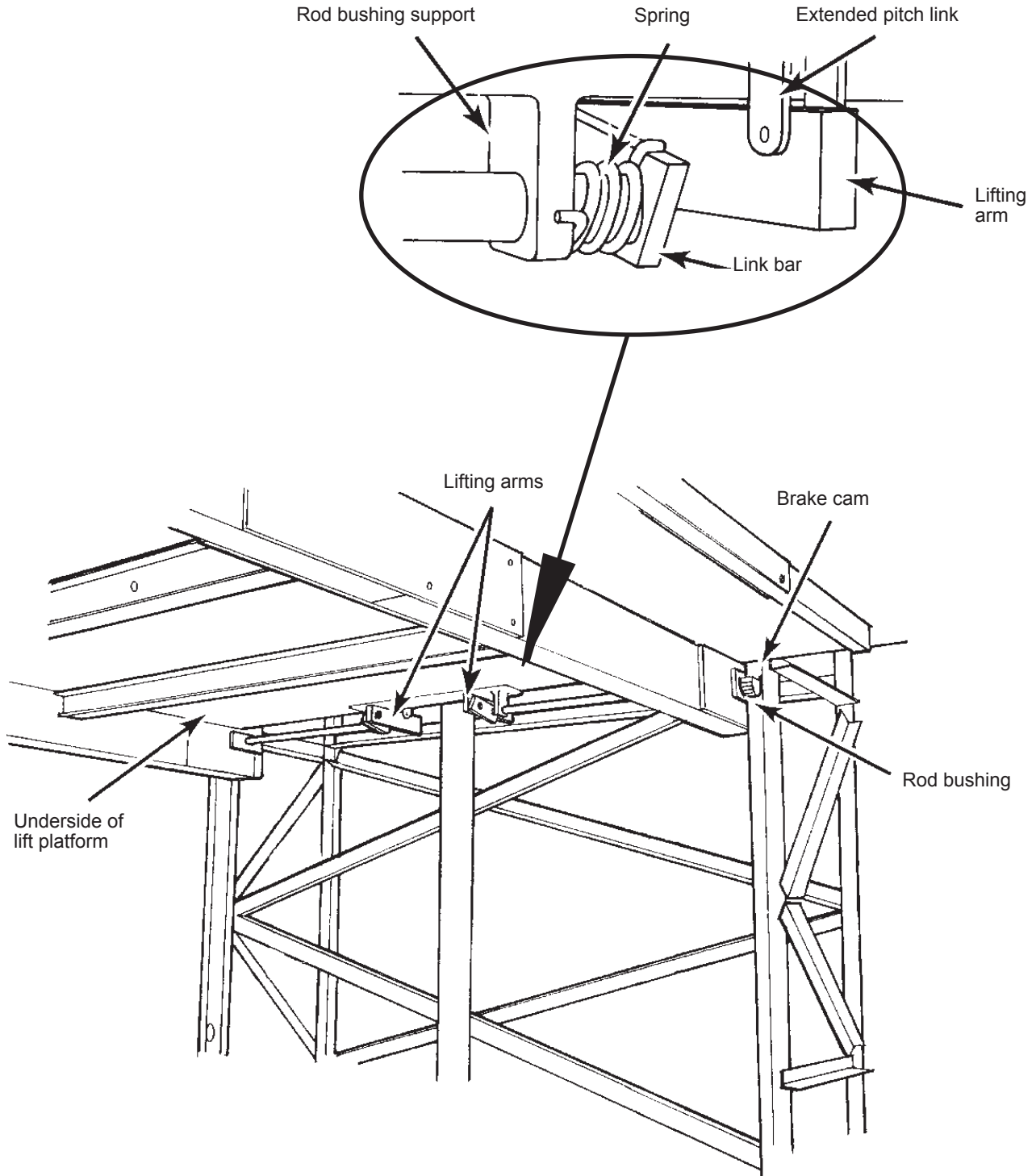
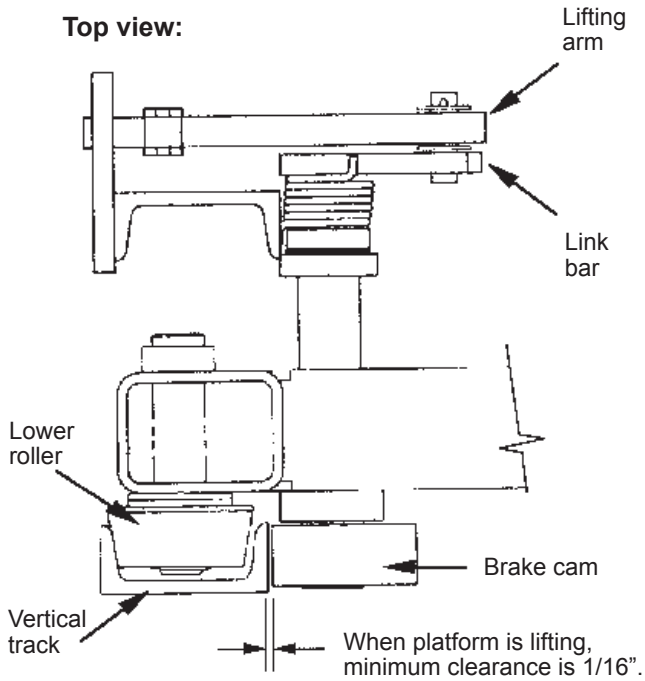

Fig. 1-13 – Brake Mechanism

A When Lifting

Top view:



Side view:

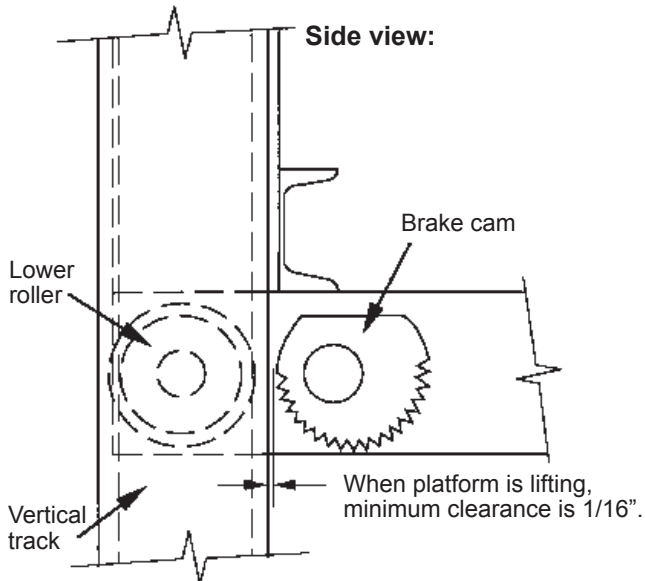

B Platform pulled forward (support under front edge)

Top view:

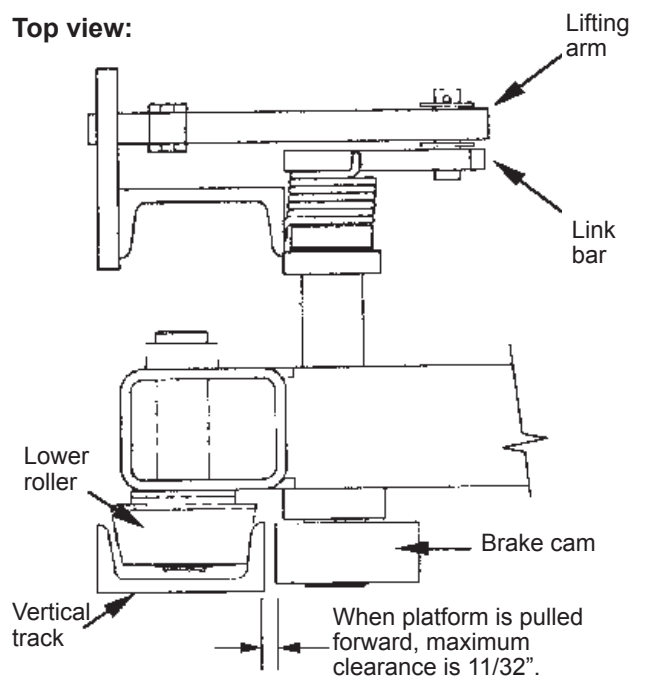

Side view:

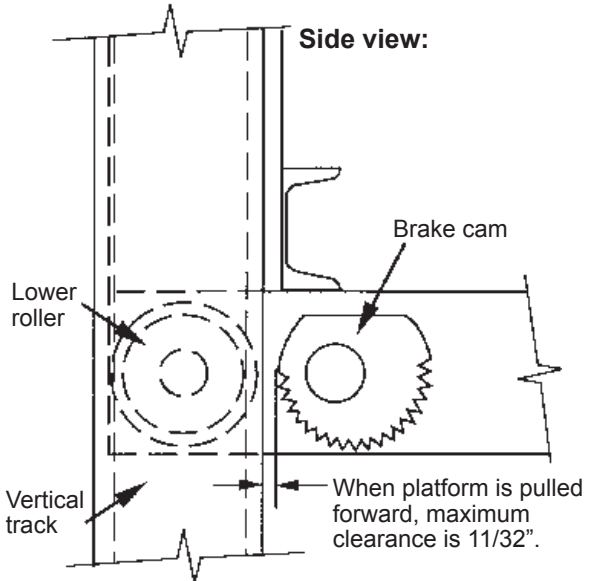

Fig. 1-14 – Roller Clearance

Vertical Reciprocating Conveyor

Fig. 1-15 – Supporting the Front of the Table

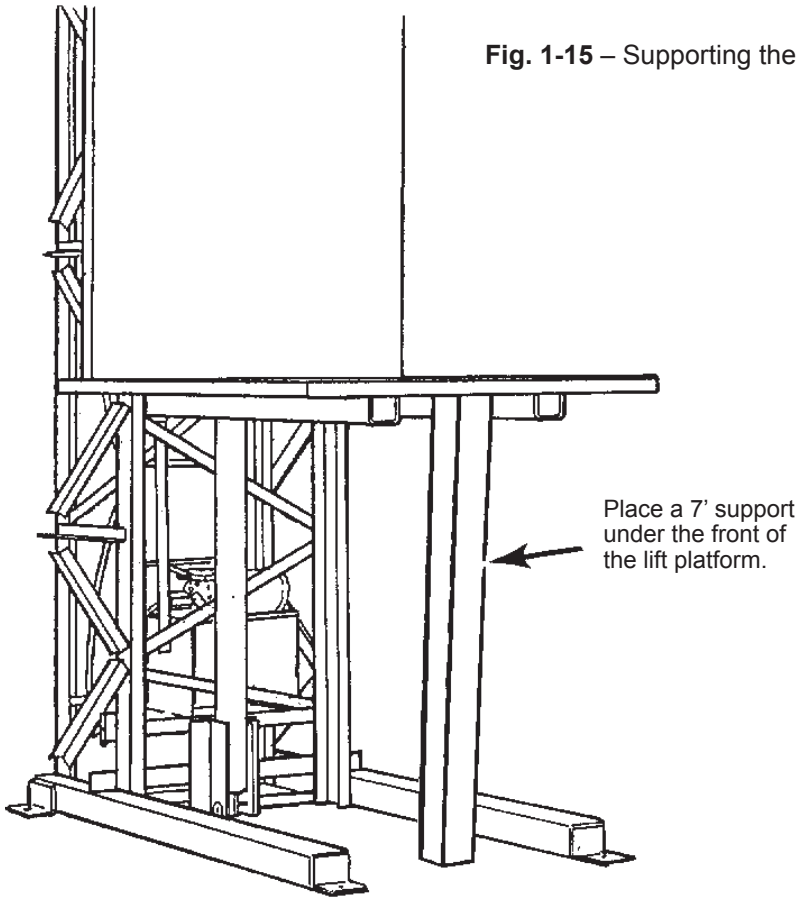
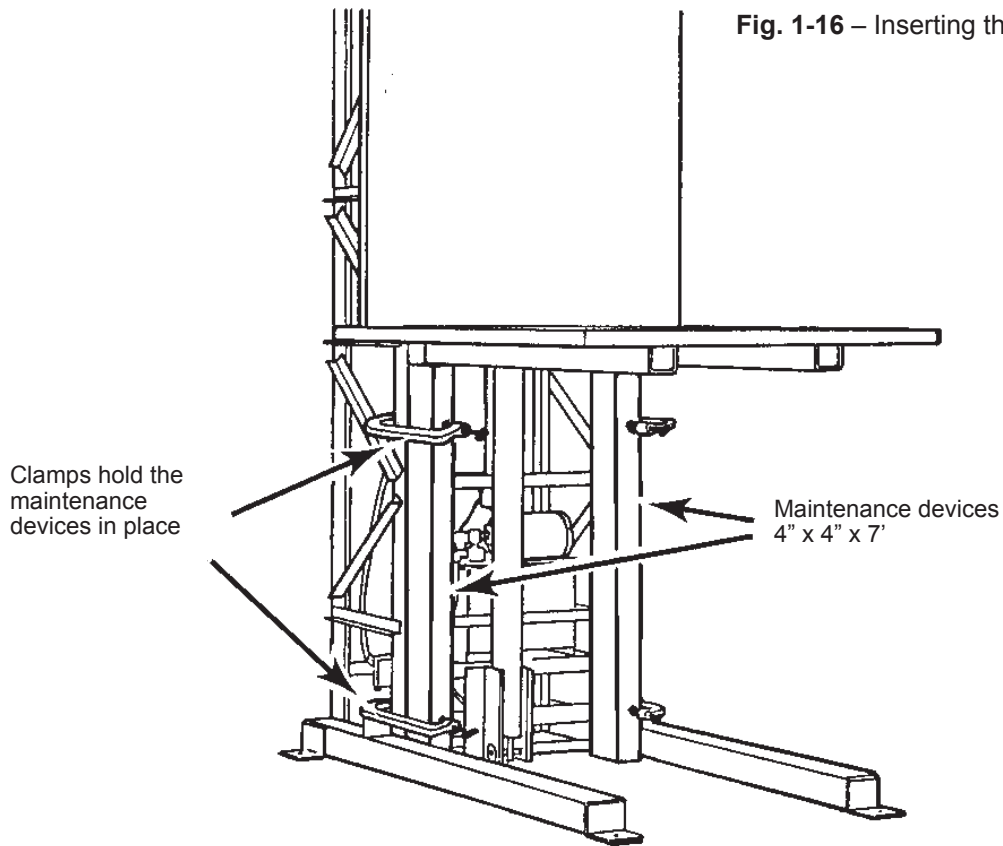

Fig. 1-16 – Inserting the Maintenance Devices



6. With a hammer and a brass pin, tap on the outer end of the axle until it is completely separated from the wheel and washers. Now you can slide the shaft toward the platform frame and remove the wheel. The wheel and washers will drop to the bottom of the side channel.
7. Each wheel includes a bushing. Normally, when the wheel is worn, the bushing is worn also. The whole assembly should be replaced as a set.
8. Hold the new wheel and washers in place on the end of the axle. Slide the end of the axle through the holes in the wheel and washers. Fit the retaining ring into place on the end of the axle. At the other end of the axle, snug the set collar up against the frame of the lift platform, and tighten the set screw. Be sure the wheel can turn freely.
9. Turn on the main disconnect. Raise the lift platform to release the maintenance devices. Remove the devices, and run the unit through a few cycles. Check the wheel assembly to be sure it is turning freely.

Replacing the Lifting Chains

1. The lifting chains carry the whole weight of the lift platform and the load. Therefore, it is very important

that these chains be in good shape. If any one of the lifting chains is damaged, replace all of the chains as a set. A chain should be replaced if:

- Any strand has stretched more than 3%. Use a chain wear scale to check the distance between pins.
 - The links are rusted or corroded.
 - Some of the links have damaged plates, pins or rollers.
 - Some of the links move stiffly when the chain section is turned around a wheel.
2. When you replace the chains, also replace the connecting links at each end of each chain. You can order replacement chains and connecting links from Southworth. See the section on "Ordering Replacement Parts" at the end of this manual.
 3. Do **not** use a degreaser to clean new chains. This will remove the lubricant inside the chain rollers, and cause the chain to wear more quickly. Do not paint the new chains. The lubricant used on the chains may dissolve the paint, and paint chips may clog up the working parts of the chain.
 4. After replacement, check the tension on each chain. See the section on "Adjusting the Lifting Chains."

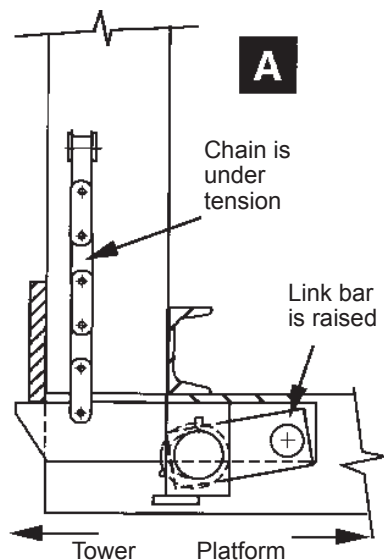

Brake link bar and lifting arm in normal (working) position, with brake mechanism not engaged:

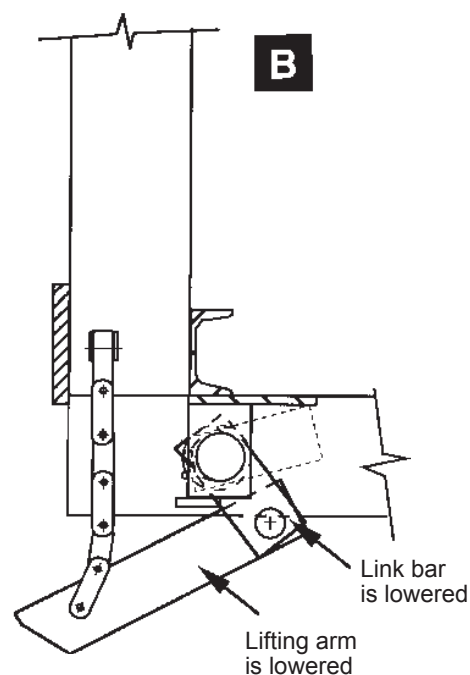

Brake link bar and lifting arm in rotated position with brake mechanism engaged due to broken or slack chain:

Fig. 1-17 – Brake Link Pin Positions

Vertical Reciprocating Conveyor

Adjusting the Lifting Chains

CAUTION

If the lifting chains are not adjusted correctly, the brake mechanism may engage incorrectly. The lifting platform may be tilted as it moves, and this can affect the efficiency of the unit.

1. The lifting chains pass over the equalizing head plate. This head plate is designed to maintain equal pressure on the lifting chains. If the head plate becomes tilted, or if the chains on one side become slack when the lift platform is lowered, you should adjust the lifting chains. (This will be visible from the rear of the unit as it is operating.) We have shown the head plate assembly in Fig. 1-19.
2. Lower the lift platform and check that the cylinder is completely bottomed out. It is important that the platform be resting on the floor when you make this adjustment. Use the manual lowering valve to be sure the cylinder is completely bottomed out. (This control will energize the down valve and release the pressure from the hydraulic ram.) The brake link pin should be in the position shown in Fig. 1-17. (If the adjustment is incorrect, the brake link may be in the position shown in Fig. 1-17, or could snap into the position shown in Fig. 1-11.) If the brake mechanism is out of position, try to reset it by lifting and lowering the lift platform. You may also need to reset it as shown in Fig. 1-11. Remember to stay out from under the lift platform as you do this.
3. Turn off the main disconnect. This will prevent someone else from starting the lift by accident. On each of the adjusting mechanisms, loosen the jam nut. (This is the lower nut on each assembly.) Once the jam nut is loose, you will be able to turn the adjusting nut (the upper nut) on each assembly.
4. If you can't lower the lift platform completely, the lifting chains are too tight. To correct this, you will have to make each chain assembly a little longer. On each adjusting mechanism, turn each adjusting nut to the left so the nut moves downward on the threaded shaft. Turn the nut on each assembly the same amount, so the equalizing head plate remains level. Continue doing this until the lift platform is completely lowered.
5. If the equalizing head plate is tilting to one side, you will have to lengthen one chain assembly, and shorten the other, until the head plate is level. If one side of the head plate is low, make the chain assembly on that side a bit longer. On the adjusting mechanism, turn the adjusting nut to the left so the nut moves downward on the threaded shaft. If the other side of the head plate is high, make the chain assembly on that side a bit shorter.
On the adjusting mechanism, turn the adjusting

nut to the right so the nut moves upward on the threaded shaft.

6. Once you have made the adjustments, tighten each of the jam nuts to keep the adjusting nuts from moving. A cotter pin is inserted in the lower end of each threaded shaft. Replace these pins if they have been removed or damaged.

CAUTION

Failure to secure the jam nuts and cotter pins may allow the chains to slip out of adjustment.

Replacing the Head Plate Load Rollers or Bearings

CAUTION

If the head plate rollers or bearings are worn, this can allow a chain to slip a tooth on one of the rollers. This will affect the efficiency of the lift.

1. Both of the lifting chains pass over the equalizing head plate. During lifting, this head plate is designed to maintain equal upward lifting pressure on the two chains. We have shown the head plate assembly in Fig. 1-19.
2. To check the condition of the load rollers, lower the lift platform completely. By pulling on the chain sections as they pass over each load roller, you should be able to determine whether there is any wear or "play" in the roller bearings. The roller should sit in place firmly, without any excess free movement. If one of the rollers is worn, you should replace them both as a set.
3. To change the load rollers, you must remove the head plate. Lower the lift platform. Turn off the main disconnect switch. This will prevent someone else from starting the unit by accident.
4. On each of the adjusting mechanisms, loosen the jam nut. (This is the lower nut on each assembly.) Once the jam nut is loose, you will be able to turn the adjusting nut (the upper nut) on each assembly.
5. Place a small torpedo level on top of the head plates. Loosen the adjustments for both of the lifting chains. On each adjusting mechanism, turn each adjusting nut to the left so the nut moves downward on the threaded shaft. Adjust the nut on each assembly so that the equalizing head plate remains level.
6. Now you can remove the load rollers. Each roller is held in place by a hex-head cap screw. Undo the nut on each cap screw. Remove the nut and lockwasher. Pull each cap screw out of the assembly, and the load roller will fall out.

7. Spin each load roller by hand. It should turn smoothly and easily. Check for excessive free play in each bearing. Inspect the outer diameter of each load roller. A roller should be replaced if the guide teeth are damaged or excessively worn.
8. Replace the load rollers and/or bearings as necessary. On each side, replace the cap screw, lockwasher, and nut.
9. Now you can re-tighten the lifting chains. On each adjusting mechanism, turn each adjusting nut to the right so the nut moves upward on the threaded shaft. Turn the nut on each assembly the same amount, so the equalizing head plate remains level. Follow the procedure listed in the section on "Adjusting the Lifting Chains."
10. Once you have made the adjustments, tighten each of the jam nuts to keep the adjusting nuts from moving. Finally, replace the cotter pins in the lower end of each threaded shaft.

Adjusting the Stabilization Chains

1. Some large Southworth VRC units are equipped with stabilization chains. These chains are designed to keep the lift platform steady as the unit lifts loads which are very heavy or off-centered. (Note that some lifts have **two** sets of chains: the **stabilization** chains and the **lifting** chains. The lifting chains are connected to the hydraulic ram.)
2. If these chains are not adjusted correctly, the lift platform may not be steady as it operates. Instead, the platform may "walk" or chatter as it moves.
3. If your lift has these chains and you need to make this adjustment, lower the platform completely. Check to see that the platform is level in all directions.

WARNING

For maximum safety and accuracy, the stabilization chains should be adjusted only when the platform is lowered completely.

4. Next, change the tension on each side using the **lower** adjustments (Do not try to change the upper adjustments. The chain sections here will still be too tight.) See Fig. 1-20. The tension on each set of stabilization chains should be the same. Check the chain tension using the method shown in the figure. When the tension is correct, you should be able to squeeze the chain sections together firmly so they just touch.
5. If the chain sections do not touch, you should loosen the chain a bit. If the chain sections move together too easily, tighten the chain. The lower adjusting mechanism for each chain is located where the chain is attached to the back of the lift platform. Each lower adjusting mechanism includes a threaded rod, a pair of locking nuts, and a cotter pin.
6. To make an adjustment, back off the upper locking nut by turning it to the left (clockwise). To tighten the chain, turn the lower locking nut to the right. To loosen the chain, turn the lower locking nut to the left. Check the adjustment by gripping the chain sections again, as shown in Fig. 1-20.
7. To hold the adjustment, bring the upper locking nut down against the lower nut. Turn the upper locking nut to the right (counter-clockwise) to jam the two nuts together.

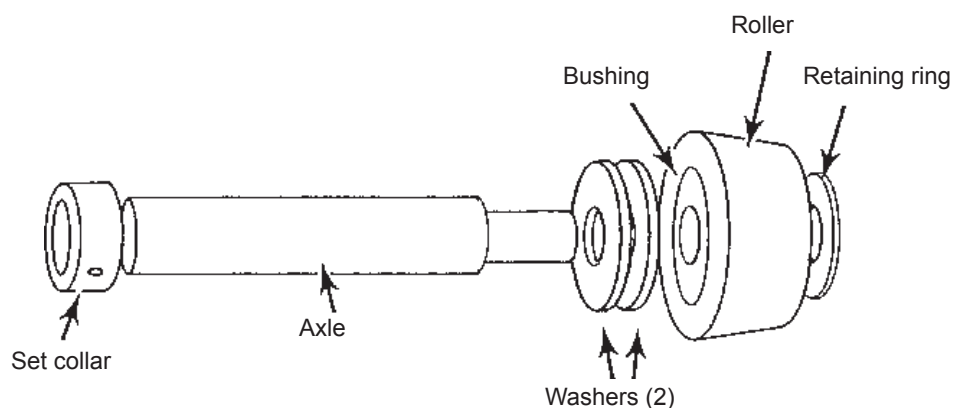

Fig. 1-18 – Roller Assembly

Vertical Reciprocating Conveyor

Replacing the Ram Gland Packing

CAUTION

Hydraulic fluid leaking onto the floor may be slippery. If a unit is operated with a leaking ram, the lift platform may not stop at the correct levels.

1. If you notice any hydraulic fluid leaking around the rod, the gland packing should be replaced. Figure 1-21 shows the packing used on the VRC unit. The gland nut is made of bronze. The primary lipseal is mounted in the lower part of the gland nut, and a double wiper is mounted in the upper part. The upper end of the ram is designed so the gland nut can be completely removed. This means you can service the gland nut at the workbench. This arrangement also makes it possible to remove the rod for inspection or replacement.
2. Lower the lift platform as far as possible. Turn off the main disconnect switch. This will keep anyone from operating the unit by accident.
3. Remove the equalizing head plate assembly from the top of the ram. See Fig. 1-19. Undo the hex head cap screws on either side of the assembly and disconnect the lifting chains. In the center of the assembly, remove one of the cotter pins and pull out the eye pin. Lift the head plate assembly off of the end of the ram.
4. Check the upper end of the rod. Sometimes burrs may develop, or metal chips may collect here.
These chips may damage the new packing seals when you re-install the gland nut. It is best to remove them now. Trim away any excess metal with a fine-tooth file, and wipe away any loose metal chips.
5. Remove the gland nut. To loosen the nut, turn it counterclockwise.
6. Slide the gland nut off of the end of the rod.
7. Pull the seals out of the grooves in the inside of the gland nut. If you intend to re-use the gland nut, be very careful as you do this. Do not make any nicks or burrs on the inside diameter of the gland nut. To pry out the seals, you can use a small screwdriver with the corners rounded off. (This will help to prevent nicking the seal.) Once you have removed the seals, clean out the grooves with a rag soaked in solvent.
8. Inspect the inside diameter of the gland nut for signs of wear. You should not see any vertical scratches or bright, worn areas on the inside diameter. If the gland nut is worn, install the seals in a new nut.
9. If the gland nut is not worn, replace just the seals. Wipe each seal, and each seal groove with clean

hydraulic oil. Install the wiper ring in the groove in the upper end of the gland nut. Be sure the back of the wiper ring is seated against the bottom of the groove.

10. Fold the backup washer a bit and fit it into the groove for the packing seal.
Be sure the back of the washer is seated against the bottom of the groove. Install the lip seal on top of the backup washer. The lip on the seal should be nearest the lower end of the gland nut, as shown in Fig. 1-21.
11. An O-ring is mounted below the threads on the gland nut. This ring keeps the hydraulic fluid from leaking through the threads on the nut. Inspect the O-ring. If it is not cut or nicked, and if the fluid has not been leaking past, you can re-use it. Otherwise, replace the O-ring.
12. Before you replace the gland nut, check the top of the rod again for any burrs. If you try to slide the gland nut over any burrs, the new seals will be damaged, and the ram will leak. Remove any burrs with a fine-tooth file and wipe away any metal chips.
13. Lubricate the inside of the gland nut with clean hydraulic fluid. Be sure to lubricate both of the seals. Also lubricate the upper part of the rod.
14. Be sure the O-ring is mounted on the outside of the gland nut, just below the threads, as shown in Fig. 1-21. Thread the gland nut into the top of the ram casing. Tighten it by turning the nut clockwise.
15. The packing seals will move into position when you apply pressure to the ram. You do not have to make any other adjustments to the seals.
16. Replace the equalizing head plate assembly. Reverse the procedure described in Step 3 above. Attach the lifting chains to the head plate assembly. Check the lifting chains as described in the section on "Adjusting the Lifting Chains."
17. Run the lift platform up and down a few times to test the new seals. You should not see more than a trace of hydraulic fluid at the upper end of the rod. If the lift platform jumps or surges as it moves up, there may be air in the hydraulic fluid. See the section on "Bleeding the Air from the System."

Bleeding the Air from the System

1. The hydraulic fluid should always be free of air bubbles. Air can be compressed, and this can put a bit of "spring" in the system and cause the rod to move with a jerky, jumping motion. Air can get into the system whenever you open one of the hydraulic fittings. If just a small amount of air gets into the

system, this will not usually affect performance. This small amount of air will eventually disappear by itself. However, if you open the gland nut at the top of the ram, or replace one of the hoses or valves, more air may get into the system. Regardless of where the air gets into the system, it tends to collect at the upper end of the ram.

2. To begin bleeding the system, lower the lift platform completely.
3. Find the bleed screw on the upper end of the rod casing. See Fig. 1-21.
4. When you open the bleed screw, try to keep the hydraulic fluid from dripping down the side of the cylinder and making a mess. Just below the bleed screw, wrap a few rags around the outside of the rod casing.
5. Raise the lift platform 4 or 5 feet. Open the bleed screw by turning it counterclockwise. A mixture of air and hydraulic fluid will escape.
6. Stop the platform after it has moved 4 or 5 feet. Close the bleed screw by turning it clockwise.
7. Lower the platform, then run the platform up and down several times to check the lifting action. If the platform continues to “jump,” there is still some air in the system. Repeat steps 5 and 6 again. You may have to do this 4 or 5 times to get all of the air out of the system.

Adjusting the Flow Control Valve

1. If the lift platform is lowering too quickly or too slowly, you can change the “down speed” by adjusting the flow control valve.

WARNING

Do not change the setting on the flow control valve unless the lift platform has been completely lowered. Do not try to adjust the flow control while pressing the “down” button, or while the lift platform is moving. If you try this, the lift platform may drop suddenly, and you may be seriously hurt. This is especially important on a lift which has the hydraulic power unit mounted in a pit.

2. To find the flow control, see Table 1-4 on the next page and refer to the correct illustration for your power unit (Fig. 1-22 or 1-23.)
3. If you want the lift platform to lower more slowly, turn the control clockwise up to 1/4 turn at a time. Make the adjustment only after you have lowered the lift platform – never while the platform is moving. If you want the lift platform to lower more quickly, turn the control counterclockwise up to 1/4 turn. Again, do this only after you have lowered the lift platform completely. Do not move the control in either direction more than 1/4 turn at a time.

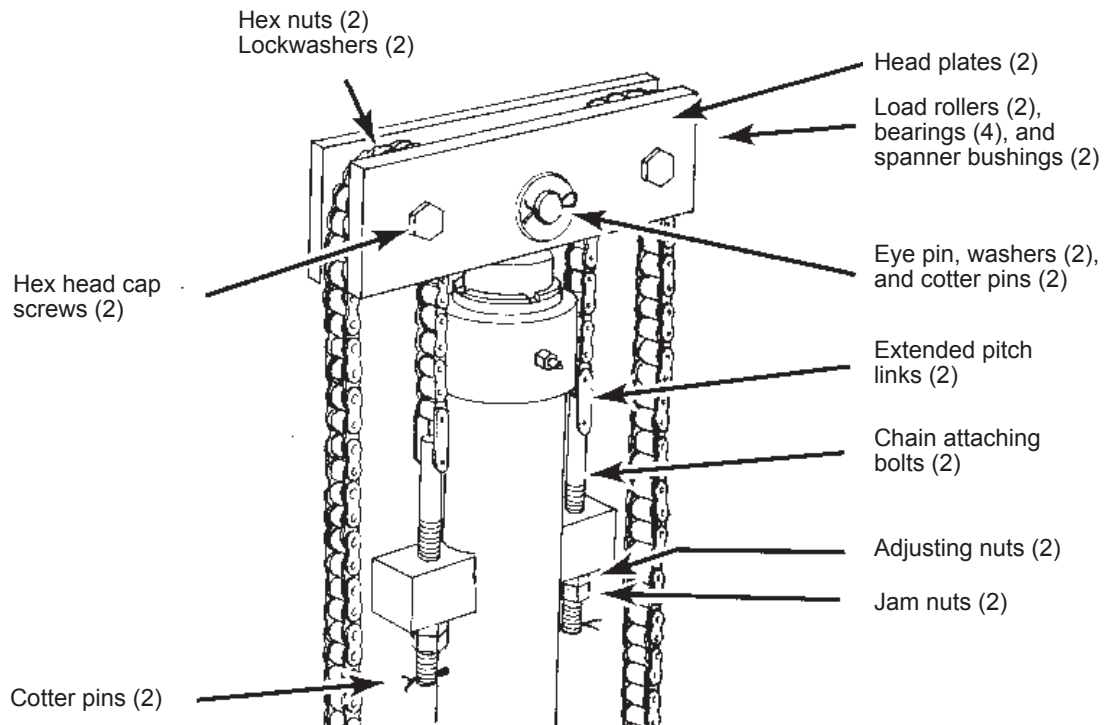

Fig. 1-19 – Equalizing Head Plate Assembly

Vertical Reciprocating Conveyor

- Operate the VRC unit, and check the speed as the lift platform moves down. You may have to adjust the control knob again. Lower the platform completely, and follow the instructions listed here, before you change the setting on the valve.

Adjusting the Relief Valve

- The relief valve is an important safety feature. This valve is designed to open when a load which is greater than the rated capacity is placed on the lift platform. When the lift mechanism tries to lift a weight, the pressure builds up inside the hydraulic system. If too great a weight is placed on the platform, the hydraulic pressure may be too great for some of the parts in the hydraulic system. Before the pressure reaches this point, the relief valve is designed to open and release the pressure. The excess hydraulic fluid flows from the pump back to the tank, without going to the ram.

⚠ WARNING

This power unit contains a hydraulic pump that is capable of developing excessive pressure. A pressure relief valve is used to set the pressure at the desired level. Tampering with, adjusting, modifying or removing the relief valve is extremely dangerous and is not recommended. Only a trained hydraulics technician, using a calibrated hydraulic pressure gauge to assure the proper pressure setting is achieved, should make adjustments to the relief valve.

⚠ CAUTION

Do not allow the VRC unit to operate with the relief valve open. Heat will build up quickly

in the pump, and this will damage some of the pump parts.

- Before each VRC unit is shipped, the relief valve is pre-set at the factory. You should not have to change the setting unless the unit will not lift the rated load, or you replace the relief valve itself.
- To find the relief valve, see Table 1-5 and refer to the correct illustration for your power unit (Fig. 1-22 or 1-23.)
- To adjust the relief setting, load the lift platform with a weight that is about 110% of the rated capacity of the VRC unit. For example, on a unit rated for 4,000 lb., place a load of 4,400 lb. on the platform.
- To make the adjustment on a Type 1 power unit, (Please note that the cap that covers the pressure relief adjustment must be on and tight with the sealing surfaces serviceable and clean before running the lift. Before making any initial adjustment ensure that the cap was already on, tight and has clean serviceable sealing surfaces at the cap to pump connection. Make sure to test after each adjustment with the cap on and sealed. Any questions or concerns call Southworth service. In all cases inspect the sealing surfaces, cap to pump connection point, and verify they are in good condition. Some caps seal with a metal washer and some with an O-ring), remove the cover cap over the relief valve adjustment. This will expose the adjustment screw. Press the up button. If the unit will not pick up the large test load, turn the screw in until the lift platform just begins to raise the load. The relief valve should be set so the valve will start to relieve with a 10% overload. When the adjustment is correct, replace the cover cap.

Type	Motor	Pump	Flow control valve location	See Fig.
Type 1 'standard'	3.2 hp	2.8 gpm	On ram	Fig. 1-25
Type 2	3.2 hp	3.9 gpm	On ram	Fig. 1-26

Table 1-4 – Flow Control Locations

Type	Motor	Pump	Relief valve location	See Fig.
Type 1 'standard'	3.2 hp	2.8 gpm	In pump	Fig. 1-25
Type 2	3.2 hp	3.9 gpm	Valve block	Fig. 1-26

Table 1-5 – Relief Valve Locations

Fig. 1-20 – Adjusting the Tension on the Stabilization Chains

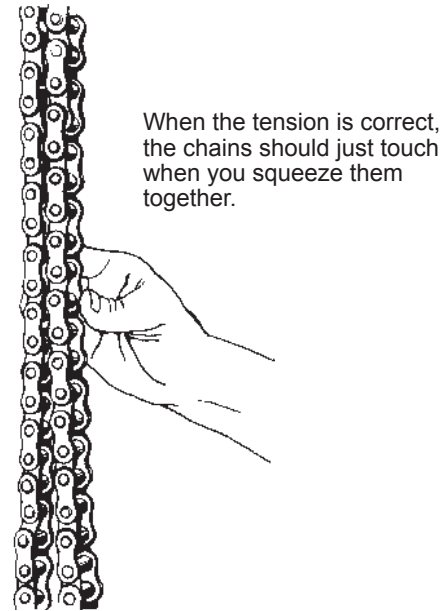
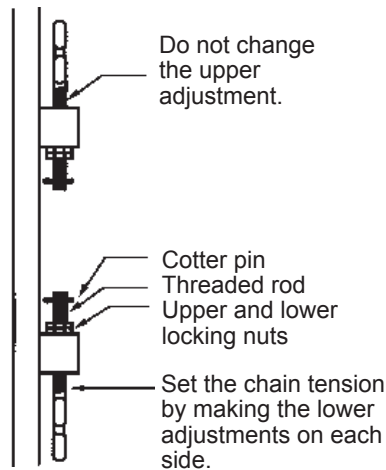

6. On a Type 2 power unit, the end of the relief valve may be covered with a plastic locking material. Peel this material away so you can turn the hex-head screw and the locking nut on the end of the valve assembly. Back off the locking nut by turning it counterclockwise. Next, press the up button. If the unit will not pick up the large test load, turn the hex-head screw in until the lift platform just begins to raise the load. The relief valve should be set so the valve will start to relieve with a 10% overload. When the adjustment is correct, hold the hex-head screw in position and tighten the locking nut. Turn the nut clockwise to lock in the setting. If possible, re-coat the end of the assembly with plastic locking material.

Checking the Down Valve

1. If the lift is not lowering when the down button is pressed, there may be a problem with the down valve. When the controller tells the lift mechanism to lower the platform, it opens the down valve. This valve allows the hydraulic fluid to flow out of the ram, and back to the tank.
2. To find the down valve, see Table 1-6 and refer to the correct illustration for your power unit (Fig. 1-22 or 1-23.)
3. Whenever the lift platform is lowering, the coil on the down valve should be energized. The coil uses 110V or 24V AC. Check for this voltage with a voltmeter. If the voltage does not appear, look for an electrical problem in the control system.
4. If the coil is working properly, the resistance should

read between 8 and 10 K Ω when tested with an ohmmeter. A reading of infinite ohms indicates a broken wire in the coil and a reading of less than normal indicates a short in the coil.

5. If the coil appears to be working, the down valve mechanism may be stuck shut or stuck open.
If this is the case, use the manual lowering valve to lower the lift platform to the full down position, relieving all hydraulic pressure in the system. (To open the manual valve, turn the knob counterclockwise. Once the platform has been lowered, turn the knob clockwise to close the valve.)
6. Turn off the main disconnect switch. This will keep anyone from operating the VRC unit by accident.
7. Unscrew the down valve. Hydraulic contamination is not uncommon. The smallest piece of dirt can cause the down valve to malfunction. **Remember that kerosene is flammable. Do not use it near an open flame.** Clean the plunger and seat with kerosene. Check that the plunger is able to move freely. If the valve still does not work correctly once it has been cleaned, replace it.

Cleaning the Suction Strainer

1. The strainer is located on the intake side of the pump. If the strainer is plugged, the unit may not lift the rated capacity. This can also cause excessive noise or vibration while the unit is operating. A blocked strainer can cause cavitation in the pump.
2. To find the suction strainer, see Table 1-7 and refer

Vertical Reciprocating Conveyor

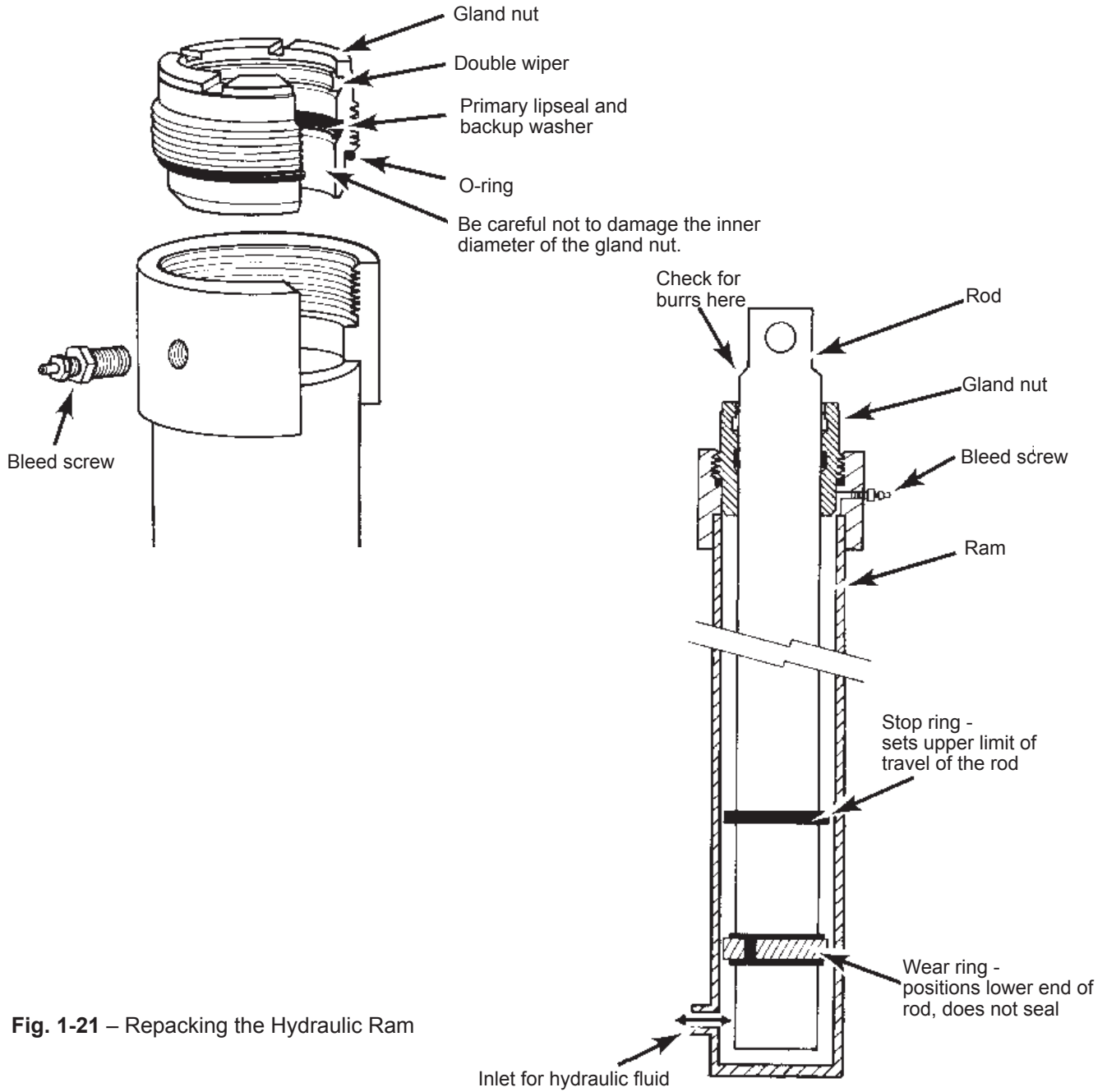

Fig. 1-21 – Repacking the Hydraulic Ram

Type	Motor	Pump	Down valve location	See Fig.
Type 1 'standard'	3.2 hp	2.8 gpm	On pump	Fig. 1-25
Type 2	3.2 hp	3.9 gpm	Valve block	Fig. 1-26

Table 1-6 – Down Valve Locations

Type	Motor	Pump	Strainer location	See Fig.
Type 1 'standard'	3.2 hp	2.8 gpm	On tank	Fig. 1-25
Type 2	3.2 hp	3.9 gpm	On tank	Fig. 1-26

Table 1-7 – Strainer Locations

Type	Motor	Pump	Check valve location	See Fig.
Type 1 'standard'	3.2 hp	2.8 gpm	Beside down valve	Fig. 1-25
Type 2	3.2 hp	3.9 gpm	On valve body	Fig. 1-26

Table 1-8 – Check Valve Locations

- to the correct illustration for your power unit (Fig. 1-22 or 1-23.)
3. To clean the strainer, lower the lift platform completely. Turn off the main disconnect switch so nobody can start the unit by accident.
 4. Unscrew the fitting at the end of the suction hose, and remove the strainer. Rinse the strainer with kerosene and blow it clean with compressed air. Replace the strainer before operating the unit again.

Cleaning the Check Valve

1. If the check valve is not seating correctly, the lift will not hold a load, and the lift platform will drift downward. Dirt on the valve seat will prevent the valve from closing fully.
2. To find the check valve, see Table 1-8 and refer to the correct illustration for your power unit (Fig. 1-22 or 1-23).
3. Lower the lift platform completely to release any pressure in the hydraulic system. Turn off the main disconnect switch so nobody can start the unit by accident.
4. Remove the check valve cap and inspect the valve for contamination which may be preventing it from closing. You may be able to restore the seal by lightly rapping the ball into the seat using a 1/4" diameter rod and a small hammer.

5. If this does not correct the problem, contact Southworth Products Corp. for further instructions.

Troubleshooting

Mechanical Problems

The equalizing head plate is not level

- Be sure the brake link pin on each side is in the normal working position. See Fig. 1-17. If the link on one side has not released, reset it manually. See Fig. 1-11.
- The lifting chains should be re-adjusted. See the section on "Adjusting the Lifting Chains."

One or both of the lifting chains are slack

- This can happen if one of the chains stretches, or if one of the adjusting mechanisms slips. It can also occur if the chains are out of adjustment in relation to the platform, so that the platform reaches the floor before the ram is completely lowered. In either case, the lifting chains should be re-adjusted. See the section on "Adjusting the Lifting Chains."

The platform guide wheels are binding

- One of the guide wheel assemblies may be damaged. See the section on "Inspecting and Replacing the Guide Wheels."

Vertical Reciprocating Conveyor

- Lubricate the inside of each vertical channel with heavy axle grease.



Be careful not to lubricate the surface of the vertical channel where the brake mechanism engages. This can interfere with the action of the brake mechanism.

The brake mechanism engages when the platform is moving down

- The lift platform may be moving down too quickly. The brake mechanism should only operate in an emergency, when the platform drops suddenly. To change the speed when the lift platform is lowering, see the section on “Adjusting the Flow Control.”
- The platform may be binding. Inspect each of the channel rails, and be sure the side rollers are not blocked.

The brake link pin is not in the normal position

- The platform rollers or vertical tracks may be worn. See Fig. 1-17 and Fig. 1-11. Read “Inspecting the Brake Mechanism” and “Testing the Brake Mechanism.”
- This can also occur if the chains are out of adjustment in relation to the platform, so that the platform reaches the floor before the ram is completely lowered. In this case, the lifting chains should be re-adjusted. See the section on “Adjusting the Lifting Chains.”

The lift platform bounces when not moving

You may notice this when you are loading or unloading the lift platform.

- The base of the VRC unit may not be supported well enough. The base frame should be supported at least every 15 inches. See Fig. 2-3 in Section 2 - “Installation.”
- Be sure that the bottom of the ram is supported.
- The ram should be free to move a bit as the lift platform moves up and down. Be sure that the ram is not attached to the frame anywhere except at the eye at the bottom of the ram.

The upper part of the mast moves when the platform is raised

- On a VRC unit with a single mast, the upper part of the mast should be attached to the building structure. On a double mast unit, only one mast should be attached. (This allows the second mast some freedom to move as the unit reacts to changing load situations.) See Section 2, “Installation.”
- On a VRC unit with one mast, the load should be placed against the back of the lift platform and centered side-to-side. See Fig. 1-7. On a unit with two masts, the load should be placed in the center

of the lift platform. .

There is a loud noise when the lift platform starts moving up

- The lifting chains may be out of adjustment. See the section on “Adjusting the Lifting Chains.”
- The suction strainer may be plugged. See the section on “Cleaning the Suction Strainer.”

When loaded, the platform does not lower completely

- Something may be blocking the vertical channels below the bottom rollers. Raise the platform and insert the maintenance devices as shown in Fig. 1-18, then remove any debris.
- There may be some debris under the lift platform. As the platform lowers, this may be causing the brake mechanism to engage. Raise the platform and insert the maintenance devices as shown in Fig. 1-16, then remove any debris. If necessary, reset the brake as shown in Fig. 1-11.

Electrical / Hydraulic Problems

The lift platform does not raise or lower, motor not running –

- Before the lift platform can move in either direction, all of the E-Stop switches must be pulled out. Check each of these switches.
- Check the main disconnect switch and all of the fuses.
- The lift platform will not move unless all of the gates are closed and interlocked. Sometimes one of the gates can become bent. If a gate does not close correctly, this can keep one of the interlock switches from working.

The lift platform does not raise, motor is running

- On a VRC unit wired for three-phase AC, the motor may not be turning in the correct direction. If the motor is turning in the wrong direction, swap any two of the power leads to the motor.
- The relief valve may be operating. The relief valve should operate only when you try to lift a load greater than the rated capacity of the unit. To check the setting, see the section on “Setting the Relief Valve.”
- The manual down valve may be open. Close the valve by tuning it clockwise.
- On a unit with an optional ram stop and pressure switch, the pressure switch may be set too low. See the section on “Installing the Ram Stop.”

The lift platform rises slowly

- The suction strainer may be partially plugged. See the section on “Cleaning the Suction Strainer.”
- Check the vented filler cap on the tank. The

breather passages may be plugged. To clean, soak the cap or plug in kerosene, then air-dry before replacing the part. **Remember that kerosene is flammable.** Do not use it near an open flame.

- The oil level may be low. When the platform is lowered, the oil level should be about $\frac{3}{4}$ " below the top of the tank. Check the level at the vented filler cap on the tank. See Fig. 1-22 or 1-23.
- The manual down valve may be open. Close the valve by tuning it clockwise.

The lift platform moves unevenly when moving up

- Check the vented filler cap on the tank. See Fig. 1-22 or 1-23. The breather passages may be plugged. To clean, soak the cap or plug in kerosene, then air-dry before replacing the part. Remember that kerosene is flammable. Do not use it near an open flame.
- The oil level may be low. When the platform is raised, the oil level should be about $\frac{3}{4}$ " above the bottom of the tank. Check the level at the vented filler cap on the tank. See Fig. 1-22 or 1-23.
- There may be some air inside the hydraulic system. See the section on "Bleeding the System."
- If you have just replaced the seals at the upper end of the cylinder, the new seals may be causing the problem. The problem may disappear when the new seals have "worn in."
- The cylinder rod may be binding. See the section on "Replacing the Ram Gland Packing."
- On a machine with an optional pressure switch (Fig. 2-16), the pressure setting may be too low. Try a higher setting.

The lift platform drops too fast or too slow

- See the section on "Adjusting the Flow Control Valve."

The lift platform does not lower

- The flow control valve may be completely closed. See the section on "Adjusting the Flow Control Valve."
- The down valve may not be operating. See the section on "Checking the Down Valve."

The lift platform drifts downward

- One of the hydraulic fittings may be leaking. Inspect them all, and tighten if necessary.
- The seals at the upper end of the cylinder may be leaking. See the section on "Replacing the Ram Gland Packing."
- The down valve may not be seating correctly. See the section on "Checking the Down Valve."
- The manual down valve may be open slightly. Close it by turning the control knob clockwise.

- The check valve may not be seating correctly. See the section on "Cleaning the Check Valve."

Oil leaks from the top of the ram

- If the oil is leaking around the top of the rod, the seals in the gland nut may be worn. See the section on "Replacing the Ram Gland Packing." Do not try to reduce the leakage by tightening the gland nut. This will only over-compress the O-ring under the gland nut. See Fig. 1-21.
- If the oil is leaking from the threads around the gland nut, the O-ring under the nut may be damaged. Remove the gland nut as described in the section on "Replacing the Ram Gland Packing." Replace the O-ring.

Vertical Reciprocating Conveyor

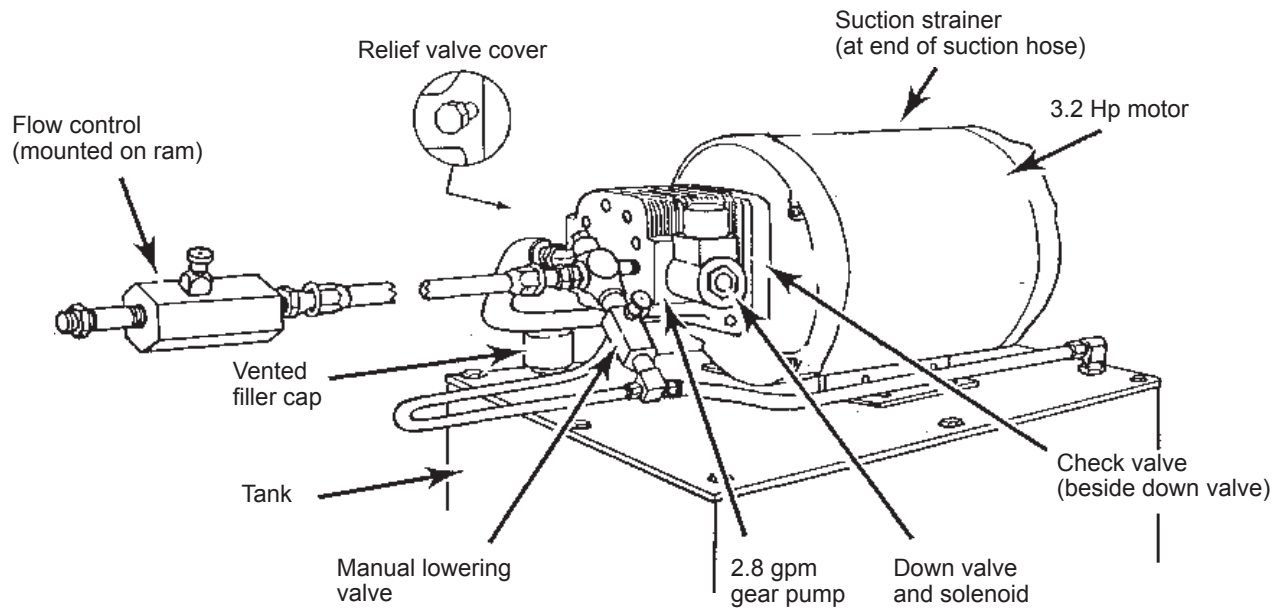

Fig. 1-22 – Type 1 (Standard) Power Unit

NOTE: The Type 1 “standard” power unit includes a 3.2 hp motor and a 2.8 gpm gear pump. The lowering solenoid and pressure relief valve and check valve are attached to the body of the gear pump.

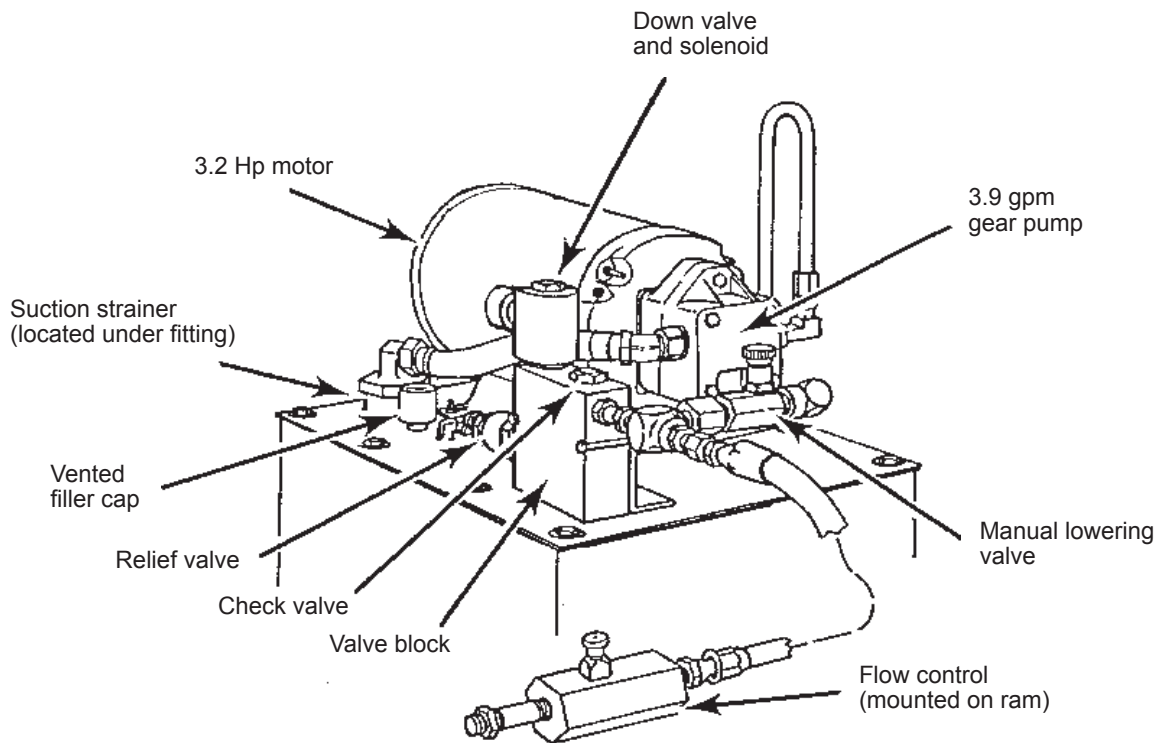

Fig. 1-23 – Type 2 Power Unit

NOTE: The Type 2 unit includes a 3.2 hp motor, and a gear pump rated at 3.9 gpm. The lowering solenoid, pressure relief valve and check valve are mounted in a separate valve block.

Parts Information

Ordering Replacement Parts

Southworth has carefully chosen appropriate components for your VRC unit. Replacement parts should be identical to the original equipment. Southworth will not be responsible for equipment failures resulting from the use of incorrect replacement parts or from unauthorized modifications to the machine.

Southworth can supply all replacement parts for your VRC unit. Refer to the illustrations in this section for help in identifying key parts of the VRC unit, as well as the illustrations listed below:

Fig. 1-1	Single-Mast Unit	page 6
Fig. 1-13	Brake Mechanism	page 25
Fig. 1-19	Equalizing Head Plate	page 32
Fig. 1-22	Type 1 Power Unit	page 39
Fig. 1-23	Type 2 Power Unit	page 39

With your order, please include the model number and the serial number of the unit. You will find these numbers on the name plate which is attached to the hydraulic tank cover.

To order replacement parts, please call Southworth's Parts Department at (207) 878-0700 or (800) 743-1000. Parts are shipped subject to the following terms:

- FOB our factory
- Returns only with the approval of our parts department.
- Payment net 30 days (except parts covered by warranty).
- Freight collect (except parts covered by warranty).
- The warranty for repair parts is 30 days from date of shipment.

Parts replaced under warranty are on a "charge-credit" basis. We will invoice you when we ship the replacement part, then credit you when you return the worn or damaged part, and we verify that it is covered by our warranty. Labor is not covered under warranty for Parts orders.

Parts Department
Southworth Products Corp

Telephone: (207) 878-0700
or (800) 743-1000
FAX: (207) 797-4734
parts@southworthproducts.com

Section 2 – Installation Instructions

Note

This manual is arranged into two sections. Section 1 covers operation and maintenance. Everyone who uses or maintains the machine should read Section 1. Section 2 includes installation instructions. This section will be most useful to workers who will install the machine.

Before Beginning the Installation

1. Please read all of these installation instructions carefully. Be sure to read and understand all of the safety warnings and precautions **before** starting the installation process.
2. Before you start to install the VRC unit, check for local codes and ordinances which may apply. It is your responsibility to get any necessary permits.
3. If your unit is designed to be installed in a pit, check the pit before you start the installation. Measure the length and width of the base of the unit, then measure the pit, and be sure the pit allows 1" clearance on all sides of the lift platform. Does the pit have a 90° angle at each corner? To check, measure across the opposite corners of the pit.

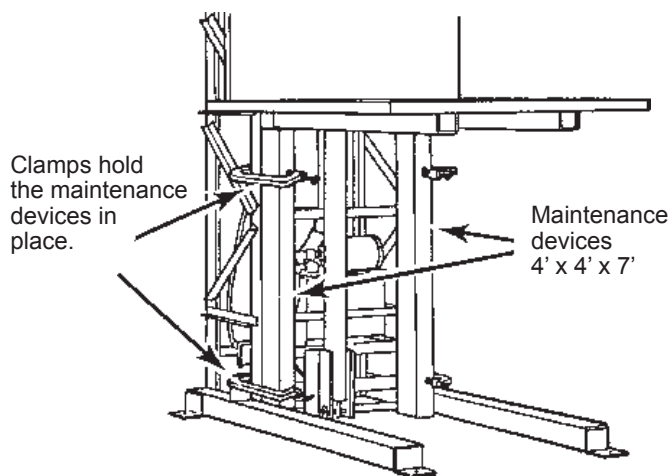

Fig. 2-1 – Working Safely Under the Lift Platform

The measurement on each diagonal should be the same, within 1/2 inch. The walls of the pit should be vertical. Check with a carpenter's level.

4. Be sure you will have easy access to the power unit once the unit has been installed. You must be able to refill the hydraulic tank, and replace the motor, pump, and hydraulic valves. If the power unit will be installed in a shaft or well, it should be possible to climb down the mast to reach the power unit. It may be helpful to install a door or access panel to make this possible.
5. If the power unit will be mounted away from the VRC unit (an "external power unit"), check the mounting position for the power unit. The power unit should be sheltered from the weather. The power unit is not sensitive to humidity, but it should be protected from rain. If the power unit will be exposed to very cold temperatures (below 0°F), use a special low-viscosity oil. Please contact Southworth for details. The power unit should be mounted within 30 feet of the VRC unit to minimize the pressure drop in the hydraulic system. Be sure the hydraulic lines have been installed properly.

Installation Quick Reference Chart

Inspect ship loose items & read ship loose instructions	Pg. 44
Temporary hydraulic & electrical hook up ..	Pg. 45
Fill the hydraulic tank with oil	Pg. 45
Align the unit	Pg. 47
Grout under base frame and install shim under cylinder	Pg. 47
Leveling and bracing the mast	Pg. 47
Make permanent hydraulic and electrical hook up	Pg. 48
Install push-button stations	Pg. 48
Install gates & interlocks	Pg. 49
Install limit switch arms & adjust	Pg. 51
Adjust lifting chains	Pg. 29
Adjust stabilizer chains (if equipped)	Pg. 30
Inspect and test safety brake mechanism ..	Pg. 21
Install ram stop and adjust pressure switch (if equipped)	Pg. 55
Operate lift to ensure proper operation	Pg. 56

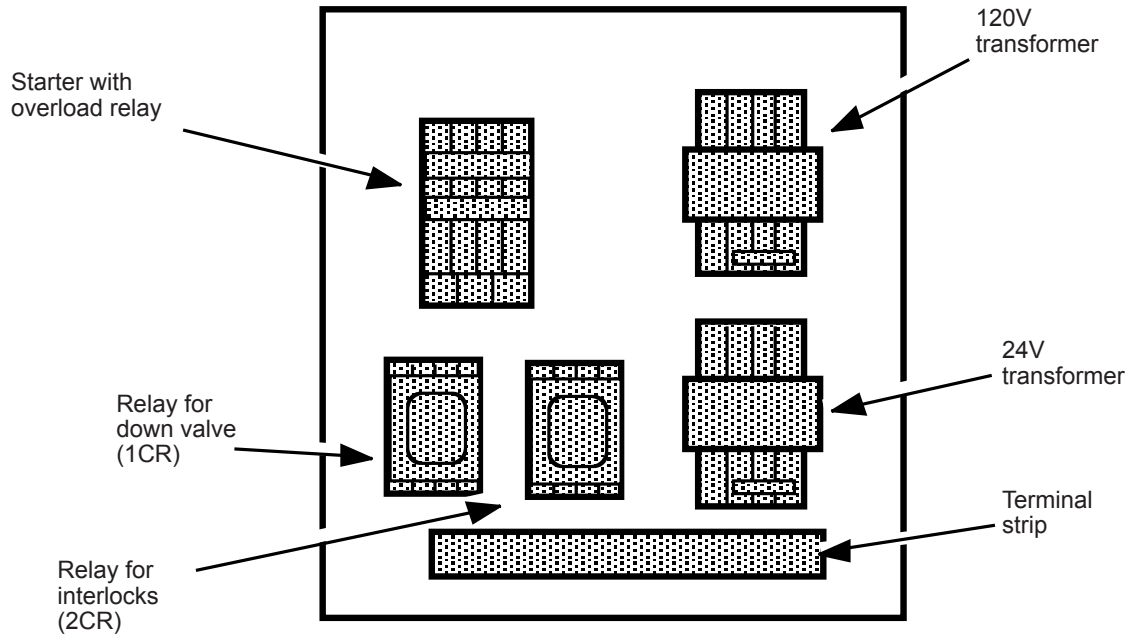

Three-level units:

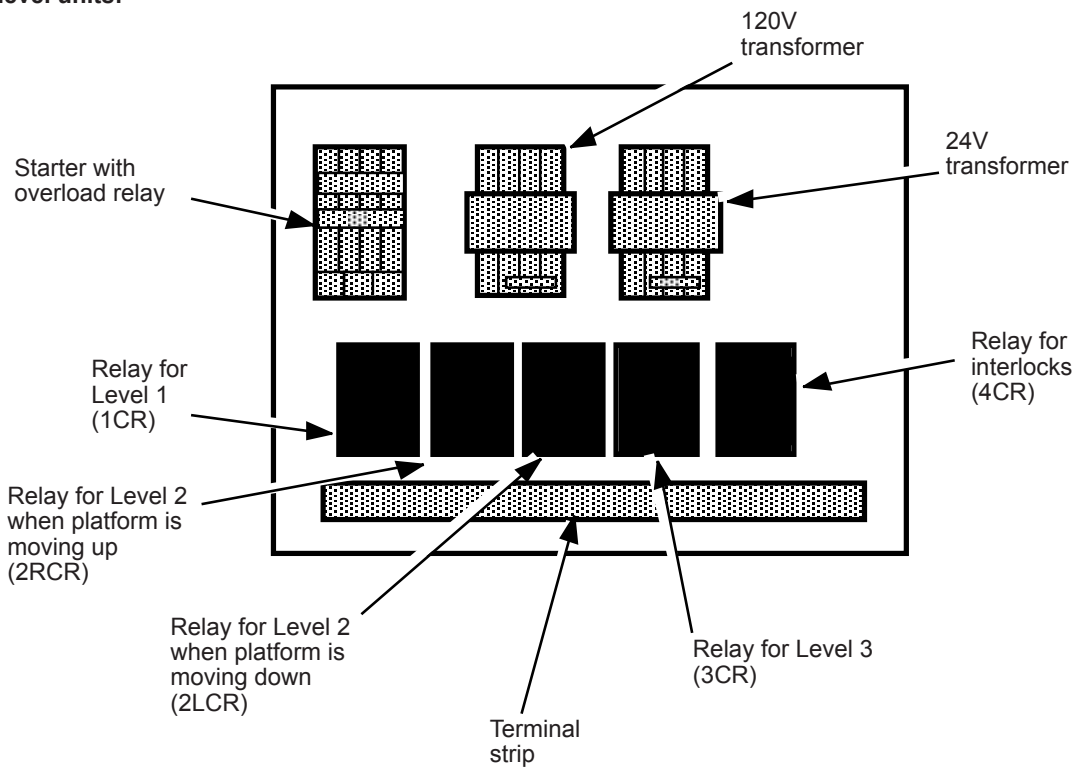

Fig. 2-2 – Control Enclosures

Vertical Reciprocating Conveyor

⚠WARNING

Protect the power unit from rain or moisture. If the electrical parts in the power unit get wet, workers may be seriously hurt, or even killed, by electrical shock. Also, the electrical parts may fail if they are wet.

⚠WARNING

The electric motor can create sparks. Do not install the power unit in an area where ignitable gases or dusts may be present, or there will be a risk of fire or explosion.

6. You will need these tools to install a VRC unit with an internal power unit:
- A device that can lift the VRC unit safely. The lifting device should have at least a 4000 lb. capacity. You can use a crane, fork lift, portable electric lift, come-along or chain fall.
 - Shims and lag bolts.
 - A masonry drill and bit to drill the holes for the lag bolts.

- Wooden maintenance devices to hold the unit in the “full up” position, as shown in Fig. 2-1.
 - Plumb line and level.
 - Welder and cutting torch for attaching braces to the frame of the unit.
 - Sledge hammer, crowbar and general mechanic’s tools.
 - A power supply with the specified voltage, including fuses or circuit breakers as specified in Table 2-1.
7. If you are installing a VRC unit with an external power unit, in addition to the above tools, you will also need:
- A compressed air source for clearing the hydraulic lines.
 - Extra hydraulic oil for flushing the underground lines and filling the tank. See Table 2-2 for the oil specifications.

Motor Voltage	Required Fuse - 1.5 HP Motor	Required Fuse - 3.2 HP Motor	Wire Gauge - 1.5 HP Motor	Wire Gauge - 3.2 HP Motor
115/1/60	25 Amp	40 Amp	12 AWG	8 AWG
230/1/60	15 Amp	20 Amp	14 AWG	12 AWG
208/3/60	-	12 Amp	-	14 AWG
230/3/60	-	12 Amp	-	14 AWG
460/3/60	-	6 Amp	-	14 AWG
575/3/60	-	5 Amp	-	14 AWG

Table 2-1 – Electrical Interface (Supplied by customer)

Type	Manufacturer
Conoco 32	Conoco
Citgo AW32	Citgo
D.T.E. 24	Mobil Oil Corporation
NUTO H32	Exxon Corporation
Amoco AW32	Amoco Corporation

Table 2-2 - Hydraulic Oil Specifications

If the lift will be used at normal ambient temperatures, Southworth supplies the unit with Conoco 32. This may be replaced by any other good quality oil with 150 SSU at 100°F and rust and oxidation inhibitors and anti-wear properties. The lubricants listed in Table 2-2 are equivalent to Conoco 32.

If the lift will be used at ambient temperatures below 0°F, use Type 15 aircraft hydraulic oil or transmission fluid.

CAUTION

It is very important to keep the hydraulic oil free of dirt, dust, metal chips, water, and other contamination. Most of the problems with hydraulic systems are caused by contamination in the oil.

Preparing the Unit

1. Remove the shipping material and unskid the unit. Be sure you have received all of the parts listed on the Bill of Lading. Some additional parts are packed in the corrugated box stored inside the mast assembly. Compare these "shipped loose" items with the enclosed checklist. Check for any damage which may have occurred during shipping. If you

do notice any damage, file a claim with the freight company. Also contact Southworth and describe the damage.

2. On the front cover of this manual, write down the model number, serial number, and date the VRC unit is placed in service. You can find the model number and serial number on the name plate. This plate is mounted on the hydraulic reservoir.
3. Measure all of the doorways and openings the unit must pass through. Be sure each section will fit through these openings.
4. Move the base section of the unit into position. Be sure to support the underside of the base section. At this point, do not bolt the base to the floor.
5. Now you can assemble the sections of the mast(s). The mast sections will be marked, so it should be obvious how they should be assembled.

At either side of each section, you will find a section of the channel for the carriage rollers. When the mast is assembled, the carriage rollers should move smoothly up and down the tracks. Before you bolt each section in place, be sure these channel sections are lined up correctly. For further instructions, see the instruction sheet included with the "shipped loose" items.

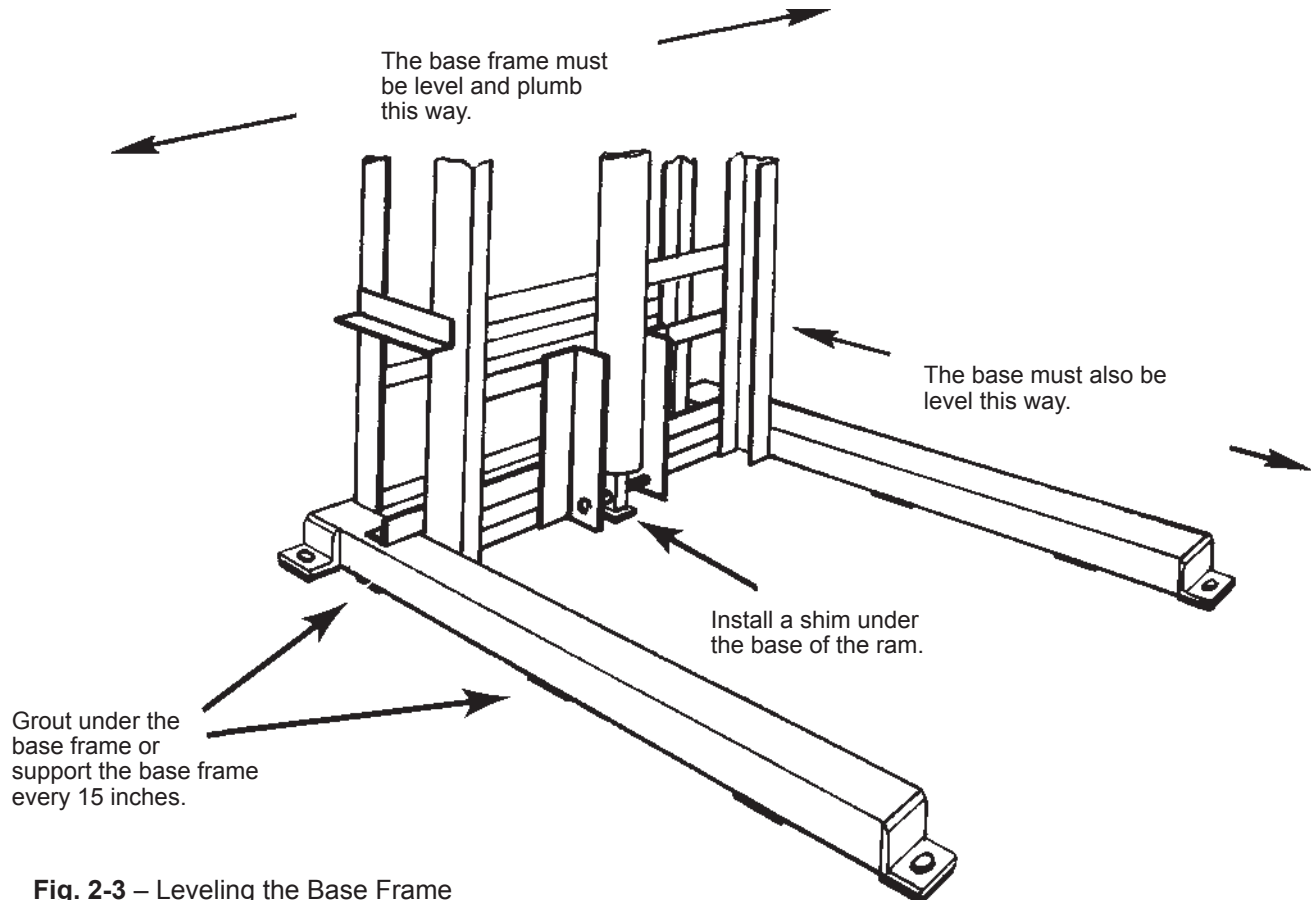

Fig. 2-3 – Leveling the Base Frame

Vertical Reciprocating Conveyor

The wires for the limit switches run along the side of the mast, and are protected by metal conduit. These wires are broken at each of the mast section joints. At each section joint, re-connect these wires. Match the number tags on the wires.

Temporary Hydraulic and Electrical Connections

⚠ DANGER

The unit may use a power supply of up to 575 Volts AC. This voltage can kill you. Do not work with the electrical power or parts unless you are a qualified electrician. Follow all applicable state codes.

1. The machine is shipped with a plastic shipping plug in the reservoir. This must be replaced with the filler breather cap supplied with the “shipped loose” items.

⚠ CAUTION

If the tank is not vented and you operate the lift, the pump may be damaged.

2. Check the oil level in the tank on the hydraulic power unit. Refer to the sight gauge on the tank. When the lift platform is lowered, the oil should be about $\frac{3}{4}$ inch from the top of the tank. Be sure to use oil with the correct specifications. See Table 2-2.
3. Make temporary power connections to the lift. See Fig. 2-2. Incoming three-phase power should be terminated at the terminals marked L1, L2 and L3

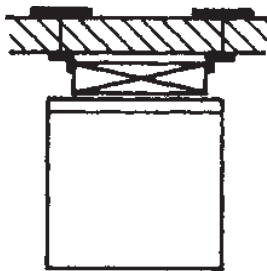

on the motor starter. For single-phase applications, use terminals L1 and L2 only. These temporary connections will allow you to operate the lift during installation.

⚠ WARNING

The fusing requirements are shown in Table 2-1. To avoid fire danger, follow these requirements.

4. In order to verify that the incoming power is connected properly and that the pump rotation is correct, jog the pump motor by manually operating the motor starter. This is done by depressing the colored insert located on the front face of the motor starter. The lift platform should start to rise when the pump motor is engaged. If the lift platform does not rise after two or three seconds, disengage the starter. Swap the connections of two of the incoming power leads and jog the starter again. If the platform still does not rise, see the troubleshooting instructions at the end of the manual.

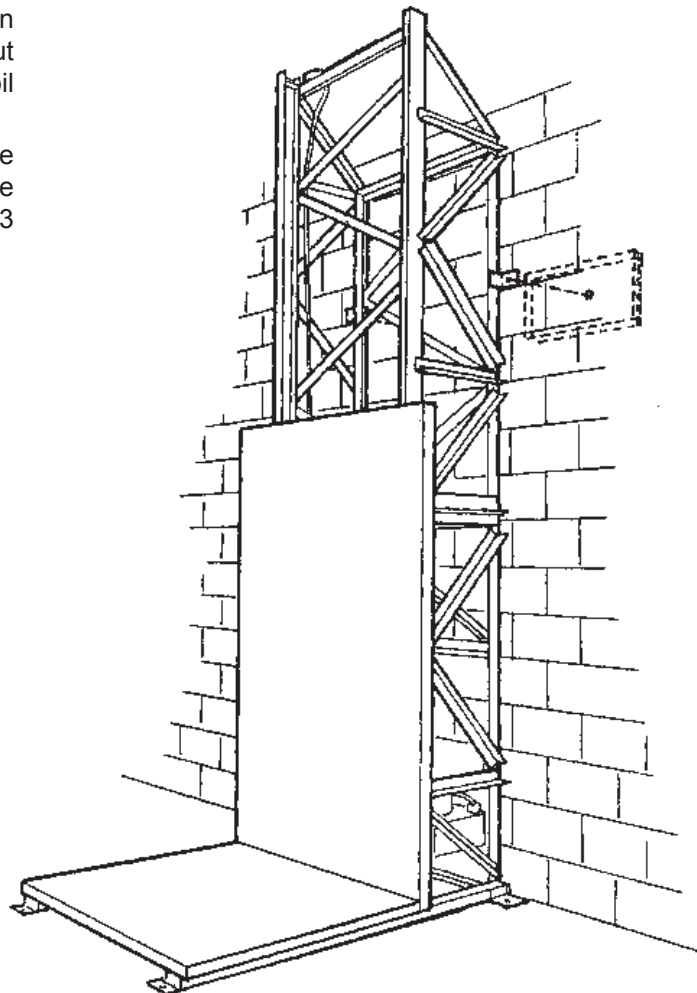

Fig. 2-4 – Bracing, Single-Mast Unit (Back to Wall)

⚠ CAUTION

If you have a unit designed for three-phase AC and you connect power so the motor runs backwards, the lift will not operate, and you may damage the pump. Do not operate the lift for more than 2 or 3 seconds if you think the motor might be turning backwards.

- For installing and testing the VRC unit, it may be necessary to run the unit before the push-button stations and interlocks have been installed. You can make some temporary connections which will allow you to both raise and lower the lift platform during installation. Shut off the power to the panel and install jumpers to temporarily bypass the interlocks. Only a trained electrician should do this. Remember to remove the jumpers after testing.

⚠ WARNING

Use these temporary connections only during installation! During installation and testing, be sure everyone working around the unit knows that the interlocks are not installed. Whenever the VRC unit is left unsupervised, make sure that the incoming power has been disconnected and locked out. This will prevent anyone from inadvertently operating the unit.

- To raise the lift platform before the interlocks and the push-button stations have been installed, manually engage the motor starter. The lift will stop raising when the motor starter is released. A jumper wire is required in order to lower the lift. The jumper allows you to “jump” power to the solenoid-operated down valve located in the power unit. Wear rubber gloves while holding the jumper wire. Touch the ends of the jumper to terminal 1 and terminal 13 on the terminal strip inside the control panel. The lift will lower while the jumper is in place. Removing the jumper will stop the lift.

⚠ WARNING

When operating the lift on a temporary basis, the end-of-travel limit switches are bypassed. Do not continue to operate the lift if the platform moves beyond the normal limits of travel. If the lift is at its upper end of travel, the pump will overheat if you allow it to continue running. This will damage the pump. Everyone working near the lift must be careful to stay away from the lift while it is moving. Once the interlocks and the push-button stations have been installed, do not use this method to operate the lift.

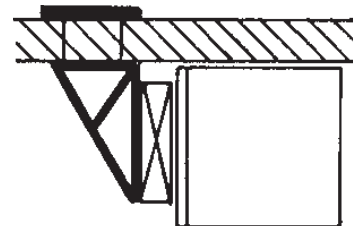
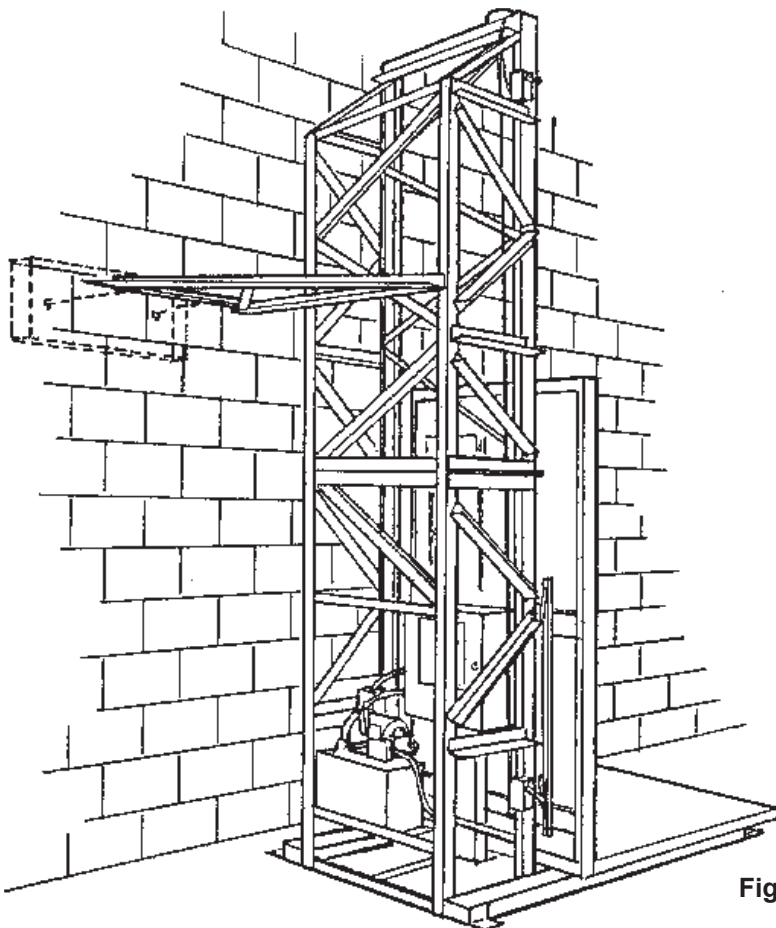

Fig. 2-5 – Bracing, Single-Mast Unit (Side to Wall)

Vertical Reciprocating Conveyor

Aligning the Unit

1. The floor below the unit must be strong and stable enough to support both the lift unit and the load. It may be necessary to reinforce the floor before you install the unit.

⚠WARNING

If the floor surface is not stable or strong enough to support the lift and the load, or to hold the base frame in place, the unit may fail suddenly. The mast may pull loose from the floor supports, or the base frame may be able to move. This can cause severe personal and/or property damage.

2. Check the alignment of the base of the unit. The base frame must be level in both dimensions (left/right and forward/back). See Fig. 2-3. Also be sure the base of the unit is well supported. If possible, grout under the whole base frame with cement. If this is not possible, there should be a strong support point at least every 15 inches along each base rail. You may use sheet metal shims for this purpose. There should also be a support under the lower end of the ram. See Fig. 2-3.
3. Raise the lift platform, and check the distance from the edge of the platform to the edge of each floor. At each level, the edge of the lift platform should be within 1" of the edge of the floor. You may have to move the base a bit (left/right or forward/back) to get the best compromise on these clearances.
4. When you are through adjusting the position of the base, re-check the level in two dimensions. This is very important to the smooth operation of the lift.

⚠WARNING

If the base is not completely level, the lift may not operate correctly. This may cause the lift platform to rack or bind as it moves. If the mast is 1" out of position at the base, the difference can be increased to 10" or more at the top. This can put very large loads on the frame members in the base and mast. In extreme cases, a non-level installation can cause the base frame or mast to break free of the floor supports.

5. When you are sure the base is level, install the lag bolts. For extra support, grout under the members of the base frame with cement. This will keep the frame from flexing as the unit operates.
6. Make up one or more braces. See Fig. 2-4 or 2-5. Always place one brace near the top of the mast. Make the braces of 2" x 2" x 1/4" angle iron. Find locations on the mast where the braces will be opposite floor beams or other strong parts of the building structure. If necessary, reinforce the wall

material using a strong board or plate, and bolt through this. Weld or bolt each brace to the mast. At this point, do not attach the other end of each brace to the building.

⚠CAUTION

Do not weld the hydraulic ram to the mast. The ram should be free to move a bit as the lift operates. If the ram cannot move freely, it will wear more quickly.

7. With the plumb line, be sure the mast is vertical. Check the front and side of the mast, as shown in Fig. 2-6. When measured from the top of the mast to the bottom, the side of the mast should be within 1/4 inch of vertical. The front of the mast should be within 1/2 inch of vertical. The closer the mast is to true vertical, the smoother the lift will operate.
8. When you are sure the mast is really vertical, attach the brace(s) to the building structure.

Check for plumb on two sides of the mast.

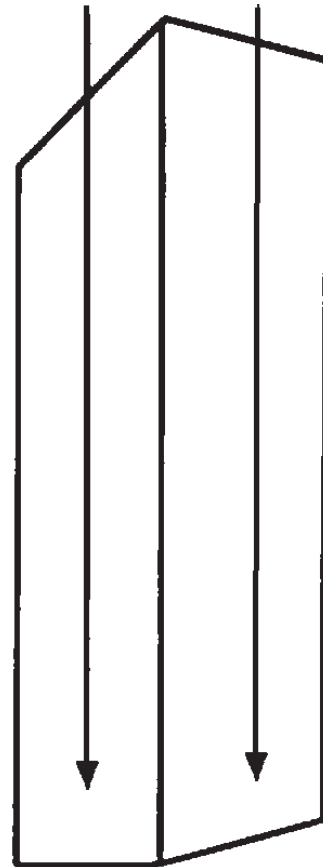

Fig. 2-6 – Checking the Mast for Plumb

Main Power Connections

⚠ DANGER

The unit may use a power supply of up to 575 Volts AC. This voltage can kill you. Do not work with the electrical power or parts unless you are a qualified electrician.

1. The customer must provide and install the main disconnect for this machine. The switch should include a lock-out/tag-out feature.
2. Make the permanent AC service connections.

Hydraulic Connections

(This section is for machines with external power units only. If you have a VRC unit with an internal power unit, go to the next section.)

1. Place the power unit in the position where it will operate. Bolt or lag the power unit securely. Run the hydraulic line between the power unit and the VRC unit. Do not connect the hydraulic line yet.
2. Blow out the hydraulic line with compressed air before connecting it to the power unit.

3. If preferred, the VRC unit may be hard-piped to the power unit. Use Schedule 80 pipe or better.

⚠ CAUTION

It is very important to keep the hydraulic oil free of dirt, dust, metal chips, water, and other contamination. Most of the problems with hydraulic systems are caused by contamination in the oil. Be sure to blow out all hydraulic lines with compressed air before connecting the external power unit.

Installing the Pushbutton Stations

1. Remove the temporary jumper wires on the terminal strip in the main control box.
2. The pushbutton stations are packed in with the other parts of the unit. Mount each station securely. Codes require that each station be mounted more than an arm's length away from the lift platform. This makes it impossible for someone to activate the lift while riding on the lift platform.

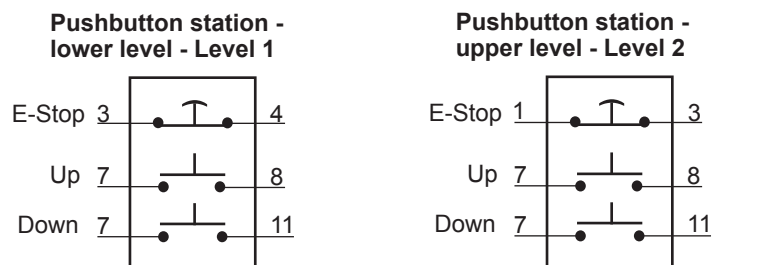

Note: The numbers shown here appear on the wires and on the installation schematics.

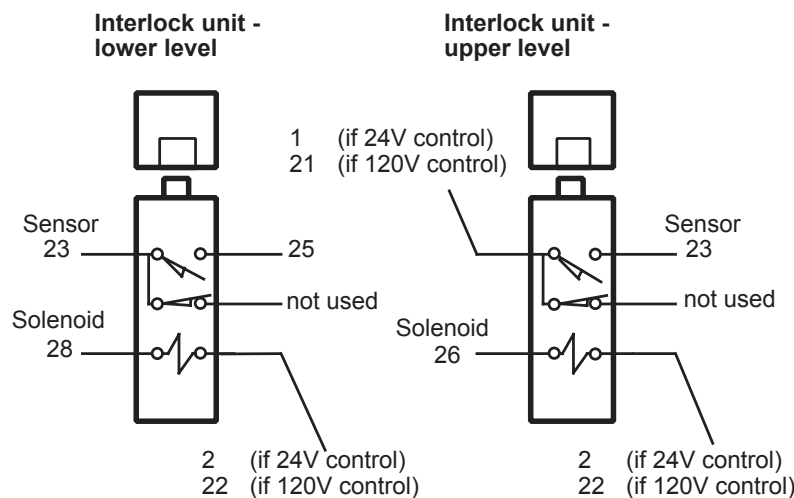

Fig. 2-7 – Pushbutton Station and Interlock Connections – Two-Level Unit

Vertical Reciprocating Conveyor



Never allow anyone to ride on the Southworth VRC. Failure to comply with this instruction could result in serious personal injury.

This vertical reciprocating conveyor, including the brake mechanism, is not designed to the same safety standards as a passenger elevator.

- Figure 2-7 shows the connections for a two-level lift. For a three-level lift, see Fig. 2-8. Run each control wire from the pushbutton station to the main control panel. Use 16 AWG wire for all control wiring (supplied by installer). Wire in the pushbutton stations according to the applicable codes. For the best possible protection against accidental damage to the wires, run the wires through metal conduit.

- To connect the pushbutton stations, run the wires from the numbered contact in the pushbutton station to the terminal with the corresponding number on the terminal strip in the main control panel. For example, on the station for Level 1, wire number 3 carries the signal from the E-Stop switch. Connect this wire to terminal 3 on the terminal strip.

Before you install each wire, double-check the wiring diagram. If there is a difference between the figures in this manual and the wiring diagram, use the connections shown on the wiring diagram.

Installing the Gates and Interlocks

- You must install gates at each floor level. (See ANSI standard B20.1.) Once the wiring is complete, you should not be able to move the lift platform unless

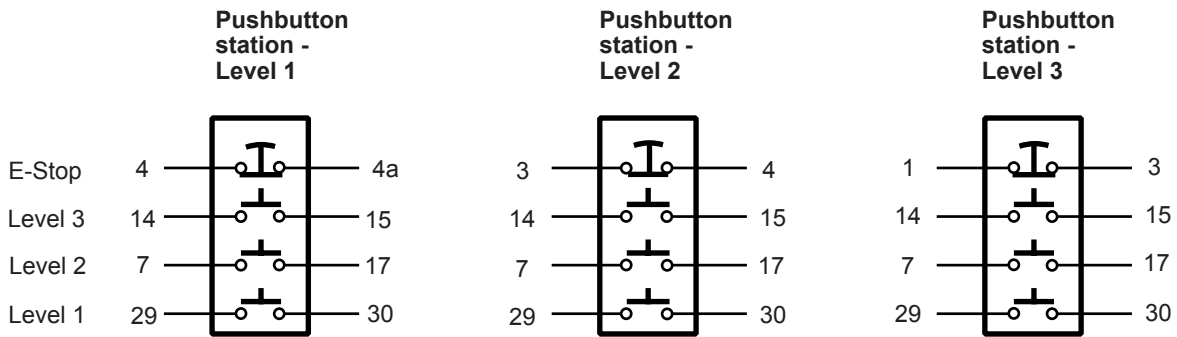

Note: The numbers shown here appear on the wires and on the installation schematics.

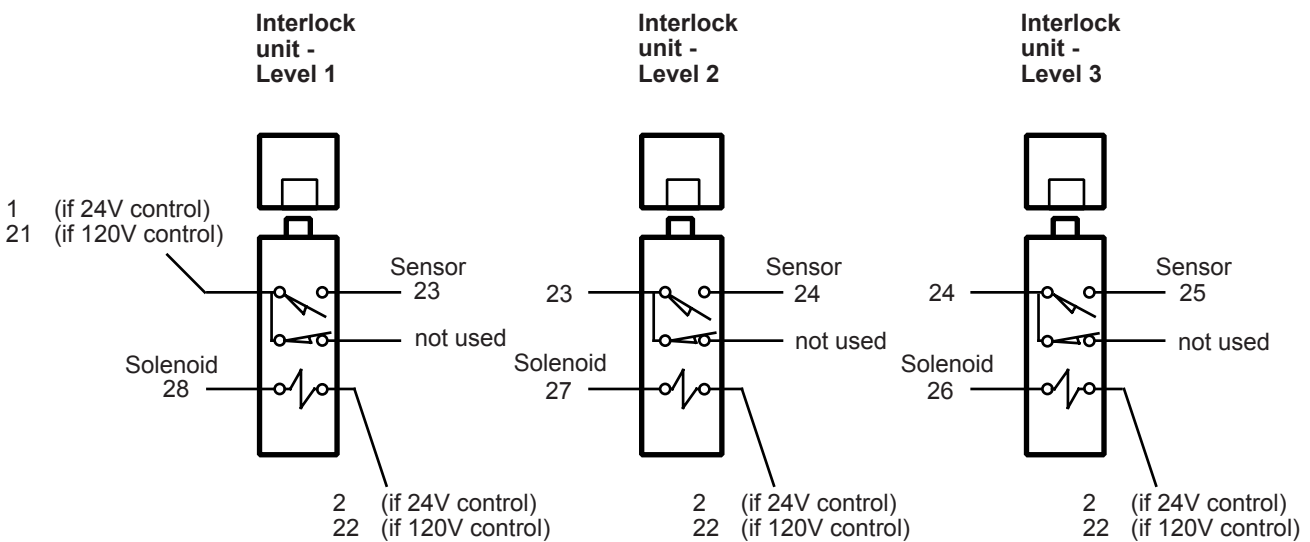

Fig. 2-8 – Pushbutton Station and Interlock Connections – Three-Level Unit

the gates on all floor levels are closed. When the lift platform stops at a floor level, you should be able to open the gate for just that floor. This is a very important feature.

⚠️WARNING

If you do not install the gates, someone may be caught between the moving lift platform and the edge of the floor. This can cause severe injury or death. The gates will keep everyone away from the moving parts of the unit. The interlocks will keep the unit from moving unless all of the gates are closed.

- Figure 2-9 shows one of the interlock units. The locking pin is moved in and out by a solenoid. Below the locking pin, the unit has a position sensing switch. The unit also includes a matching strike block.

When the unit is installed, the locking block is usually mounted on the gate, and the main part of the unit is mounted on the gate frame. Figure 2-10 shows some common mounting arrangements. (Sometimes, the main part of the unit may be mounted on the gate itself, but this is more complicated.)

The interlock unit has two functions: it serves as a physical interlock, and also sends a signal to the control system. When the gate is closed, one of the magnets on the block lines up with the position sensor switch. The switch then sends a signal to the control system that says, "This gate is completely closed." When the controller gets this signal from all levels, it allows the lift to operate.

Each locking solenoid is normally de-energized, and the locking pin is usually extended. The locking pin fits into the hole in the strike block, and this keeps anyone from opening the gate.

When the lift platform stops at a certain floor level, the control system energizes the solenoid for that floor. This causes the locking pin to pull back, and unlock the gate for just that one floor.

The controller uses a limit switch to signal when the lift platform has reached a certain floor. For example, when the platform is stopped at Level 1, the limit switch for that floor is actuated. This allows the controller to energize the solenoid for that level, and unlock the gate.

- It is easiest to mount the locking block on the gate, and the main part of the interlock device on the frame around the gate. Place the unit on the side of the gate farthest from the hinges.
- On an installation with a bi-swung gate, mount the interlock opposite the gate which closes last. This way, the locking pin will hold both gates in place.

⚠️WARNING

Incorrect installation will violate the ANSI standards, defeat the protection of the interlock, and pose a risk of serious injury or death.

- On an installation with a sliding gate, the interlock should be mounted on a line 90° to the line of motion of the gate. Be sure the locking pin will actually hold the gate in place.
- It is important to align the strike block with the main part of the interlock. The hole in the strike block should line up with the locking pin. The hole in the strike block is a bit oversized to make this easier.
- The parts which hold the interlock and the strike block in place should not be able to bend or move. If the gate is not very strong, it may be bent easily. This can prevent the interlock and the block from lining up, and keep the lift from operating. If the gate seems weak, reinforce the part of the gate which holds the interlock or strike block.

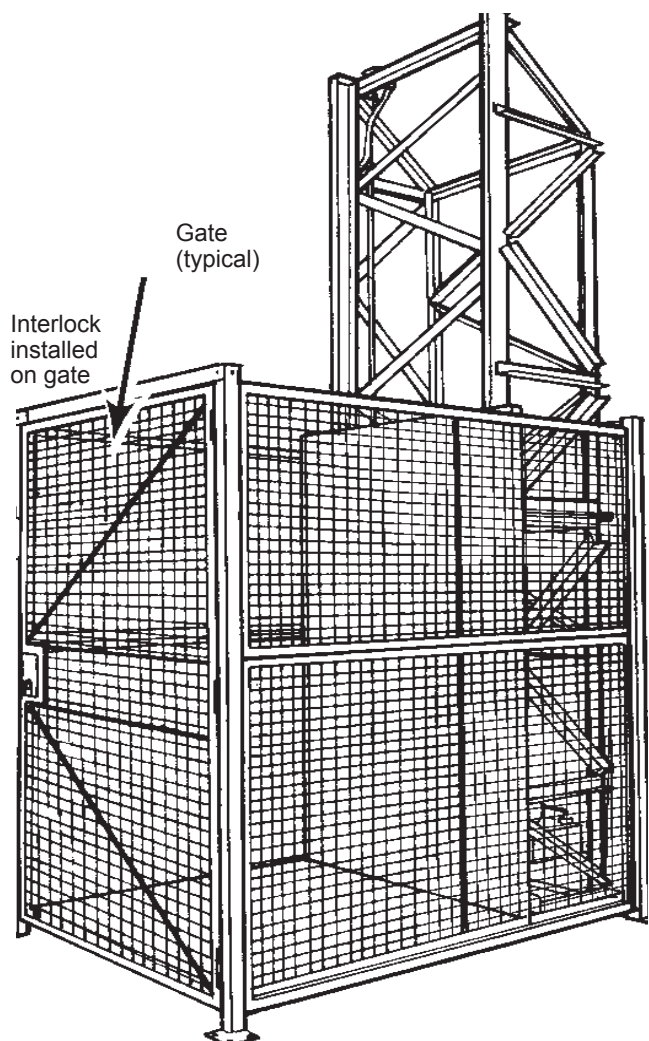

Vertical Reciprocating Conveyor

8. To connect the interlock units, match the number on each wire with the terminal on the terminal strip. For a two-level unit, see Fig. 2-7. If you have a three-level unit, see Fig. 2-8.

Adjusting the Limit Switches – Two-Level Unit

1. At each level, the lift platform should stop at the same level as the floor. On a two-level unit, there are two limit switches which control the platform stopping positions. See Fig. 2-11. To make large adjustments in the stopping point, you can move the two striker plates on the back of the lift platform. The lower striker plate sets the stopping position at the lower floor level. The upper striker plate sets the stopping position at the upper floor level. These strikers are mounted on tracks. To change the stopping position of the lift platform at a certain level, move the striker up or down in the track.
2. Start by setting the stopping position at the lower floor level. Raise the platform a bit, then lower it until it stops. (On a system with maintained contact switches, once the Down button has been pressed, the platform will move until it trips the floor level switch. On a unit with momentary contacts, you must press and hold the Down button until the

platform stops. In either case, the platform will stop when it reaches the floor level switch.)

If the platform stops below the floor level, move the lower striker down a bit. If the platform stops a bit too high, move the lower striker up. Keep making adjustments until the platform stops within about 1" of the correct floor level.

3. Now you can set the stopping position at the upper floor level. The limit switch for this level is triggered by the upper striker plate. Adjust the upper strike plate accordingly.

Adjusting the Limit Switches – Three-Level Unit

1. At each level, the lift platform should stop at the same level as the floor. On a three-level unit, there are four limit switches which control the platform stopping positions. See Fig. 2-12. There is one switch at Level 1, and one at Level 3. These switches are tripped by two striker plates, located on the left side of the rear of the lift platform.

There are also two switches for Level 2. See Fig. 2-12. These switches are activated by two strikers which are located on the right side of the lift platform.

2. Start by setting the stopping position for Level 1.

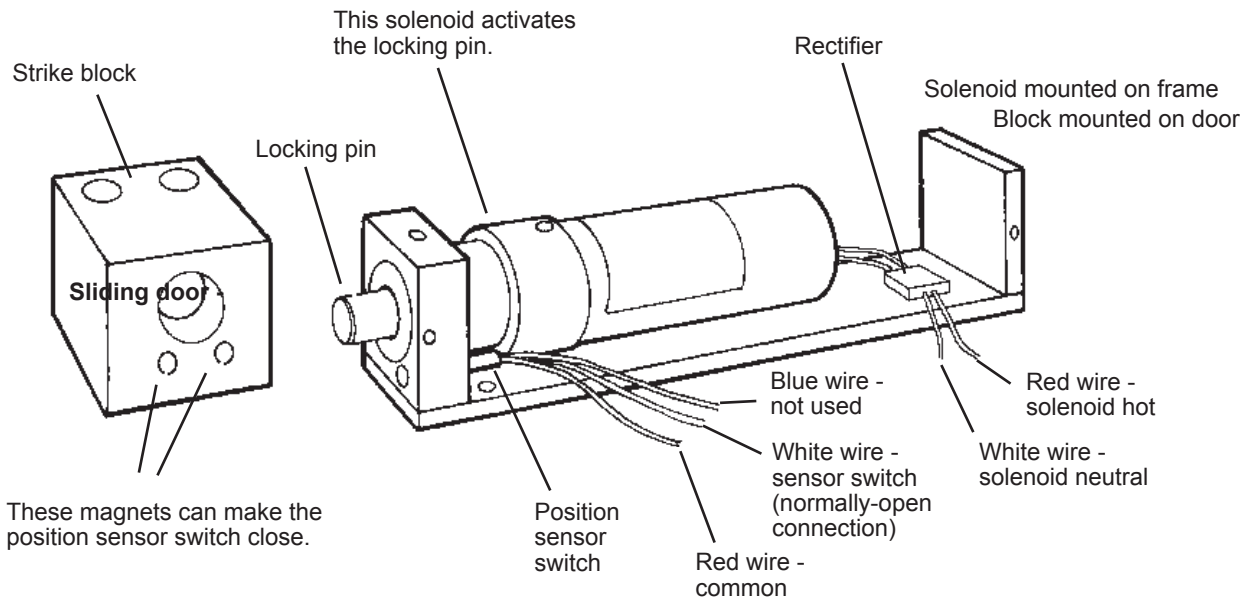

Fig. 2-9 – Interlock Unit

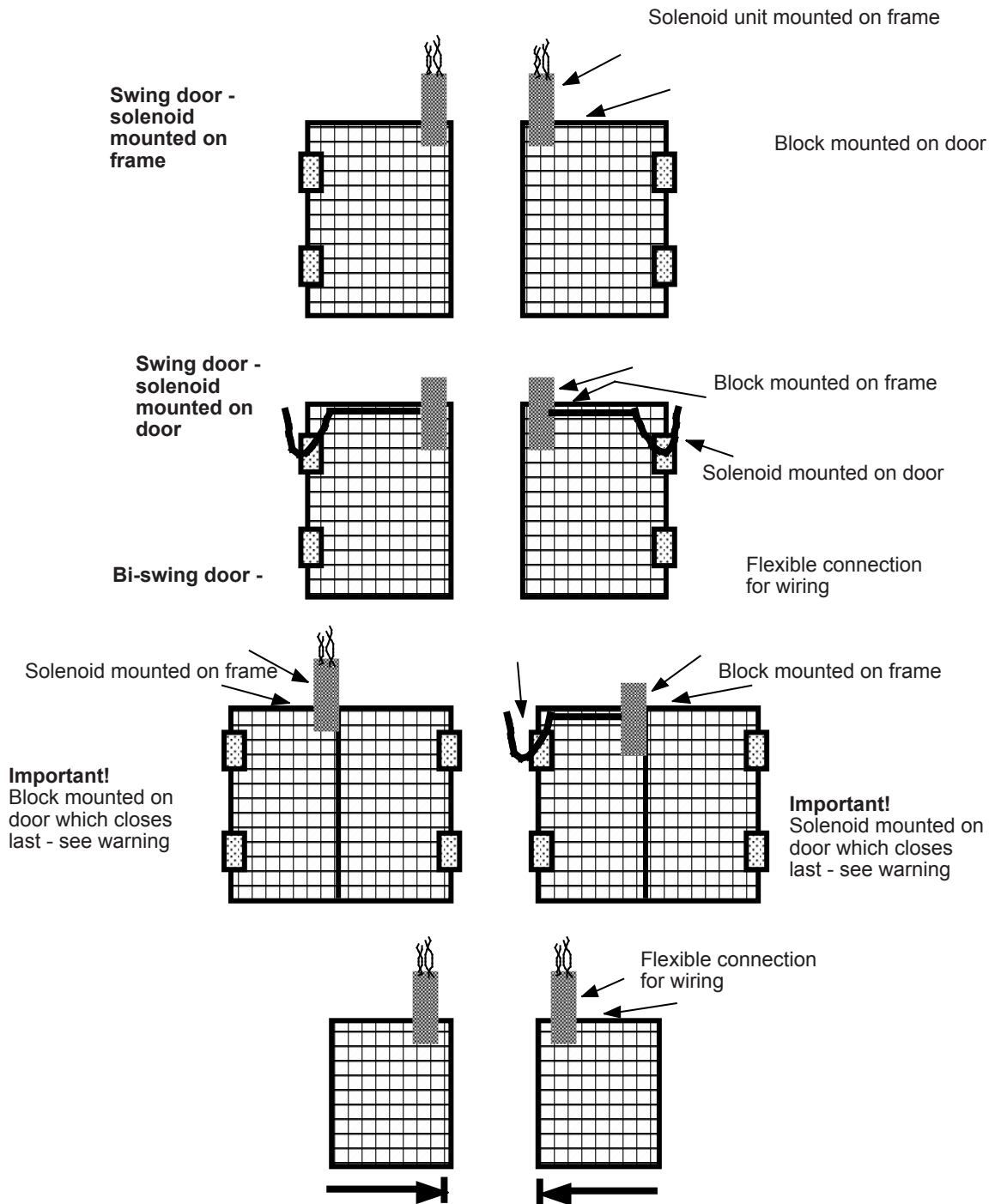

Fig. 2-10 – Mounting the Interlocks

Vertical Reciprocating Conveyor

Raise the platform a bit, then lower it until it stops. (On a system with maintained contact switches, once the Down button has been pressed, the platform will move until it trips the floor level switch. On a unit with momentary contacts, you must press and hold the Down button until the platform stops. In either case, the platform will stop when it reaches the floor level switch.)

The striker which controls this stopping position is the lower striker on the left-hand side of the lift platform. If the platform stops below the floor level, move the lower striker down a bit. If the platform stops a bit too high, move the lower striker up. Keep making adjustments until the platform stops within about 1" of the correct floor level.

3. Now you can set the stopping position for Level 3. The limit switch for this level is triggered by the upper striker plate on the left side of the platform.
4. Next, make the adjustments for Level 2. There are two separate switches. One switch sets the stopping position when the lift platform is moving up (2LSR), and the other sets the stopping position when the platform is moving down (2LSL). The striker located on the inner channel sets the stopping positions when the platform is moving down. The striker in the outer channel sets the stopping positions when the platform is moving up.

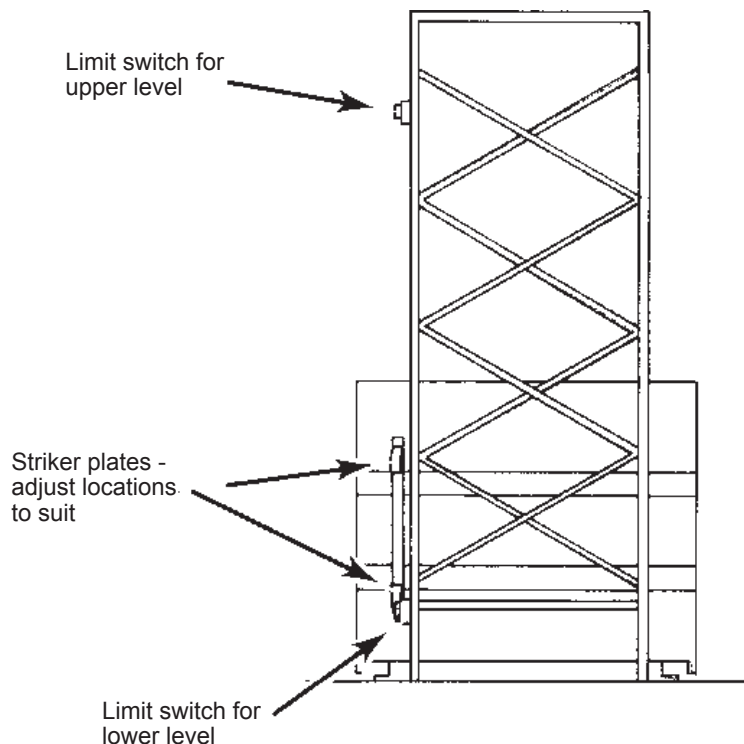

Fig. 2-11 – Limit Switches, Two-Level Unit

Adjusting the Stabilization Chains

1. Some large VRC units are equipped with stabilization chains. See Fig. 2-13. These chains are designed to keep the lift platform steady as the unit lifts loads which are very heavy or off-centered. (Note that some lifts have **two** sets of chains: the **stabilization** chains and the **lifting** chains. The lifting chains are connected to the hydraulic ram.)
2. If your lift has these chains and you want to make this adjustment, lower the platform completely. Check to see that the platform is level in all directions.



The chains should be adjusted only when the platform is lowered completely, and is level.

3. On each chain, make the **upper** adjustment first. See Fig. 2-14. On the ends of the upper torsion shaft, there are two sprockets. See Fig. 2-13. When the shaft is assembled, the teeth on these sprockets may not be aligned (they may not be "in phase"). The upper chain adjustments on each side are designed to correct for this. Begin by making the upper adjustment for the stabilization chain on one side of the mechanism. On the upper adjustment on the first side of the mechanism, set the lock nuts near the middle of the adjusting bolt. (At this point,

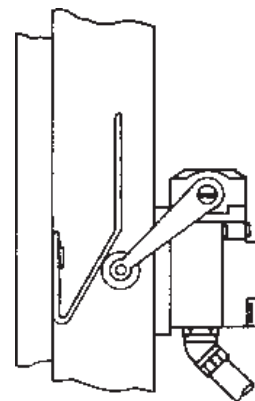

Detail - Side view of the limit switch for the lower level, shown when the lifting platform is at the lower level

Fig. 2-12 – Limit Switches, Three-Level Unit

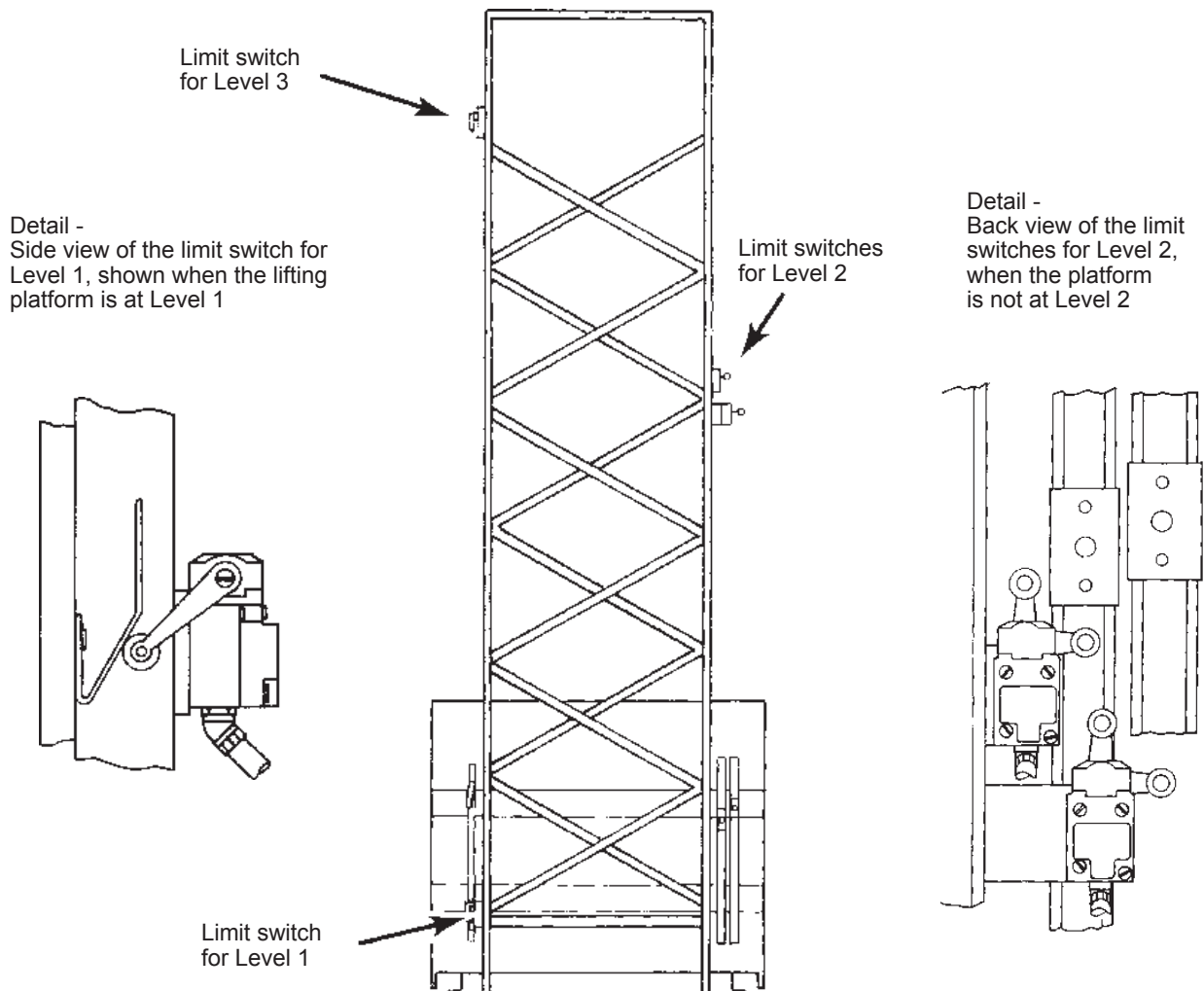

the lock nuts should be touching, but not tightened together.) See Fig. 2-14. On the other side of the mechanism, set the upper adjustment so there is no torque on the upper torsion shaft. The rollers for this second chain should sit evenly in the teeth on the sprocket, without pulling forward or back. Tighten the lock nuts on both sides. (Turn the upper nut down against the lower nut so the two nuts lock together.)

4. Next, make the lower adjustment on each side. To change the tension on a chain, always change the **lower** adjustment (This will preserve the settings on the upper adjustments.)

The tension on each set of stabilization chains should be the same. Check the chain tension using the method shown in Fig. 2-14. When the tension

is correct, you should be able to squeeze the chain sections together so they just touch.

5. If the chain sections do not touch, you should loosen the chain a bit. If the chain sections move together too easily, tighten the chain. The lower adjusting mechanism for each chain is located where the chain is attached to the back of the lift platform. Each lower adjusting mechanism includes a threaded rod, a pair of locking nuts, and a cotter pin.
6. To make an adjustment, back off the lower nut by turning it to the left. To tighten the chain, turn the upper nut to the right. To loosen the chain, turn the upper nut to the left. Check the adjustment again by gripping the chain sections again, as shown in Fig. 2-14.

Vertical Reciprocating Conveyor

7. To hold the adjustment, bring the lower nut up against the upper nut. Turn the lower nut to the right to lock the two nuts together.

Installing the Ram Stop and Adjusting the Pressure Switch

VRC units will exhibit deflection of the platform between the unloaded and loaded conditions. This is caused by compression of the hydraulic oil, and by deflection of the structure. The deflection will be most noticeable when the platform is at the upper level. The degree of deflection will vary with the rated load capacity of the unit, the platform size, and the height of the highest floor level.

Some VRC units are supplied with a pressure switch and ram stop assembly. These parts are used to stop the platform at the highest floor level. The pressure switch and ram stop also pressurize the system to eliminate platform deflection resulting from compression of the hydraulic oil. As the hydraulic pressure in the system rises above a pre-set limit, the pressure switch opens, turning off the power unit. This should happen at the same time the platform reaches the highest floor level.

The ram stop assembly is shipped loose for location at final installation. Install the ram stop and adjust the pressure switch using the following instructions:

CAUTION

On units with a pressure switch, the upper travel limit switch is only wired for a door interlock signal. The upper limit switch will not stop the platform from rising. Until the ram stop has been completely installed, the upward travel of the platform can only be stopped by using the Emergency Stop button.

1. Raise the platform until it is $\frac{1}{8}$ " below the highest floor level. This will allow for a bit of "drift" as the platform is stopping.
2. Position the ram stop to rest on the flat bar welded to the top of the cylinder ram eye.
3. Securely clamp the ram stop to the $\frac{1}{2}$ " x 6" mounting bar located on the upper mast section.
4. Lower the platform. Weld the ram stop securely to the mounting plate.
5. Lower the platform to its lowest level. Load the platform with a load which equals the rated capacity.
6. Figure 2-16 shows the pressure switch. On the pressure switch, remove the cap from the range setting adjustment screw. Turn the screw out as far as possible. This will allow the pressure switch to open at the lowest pressure.

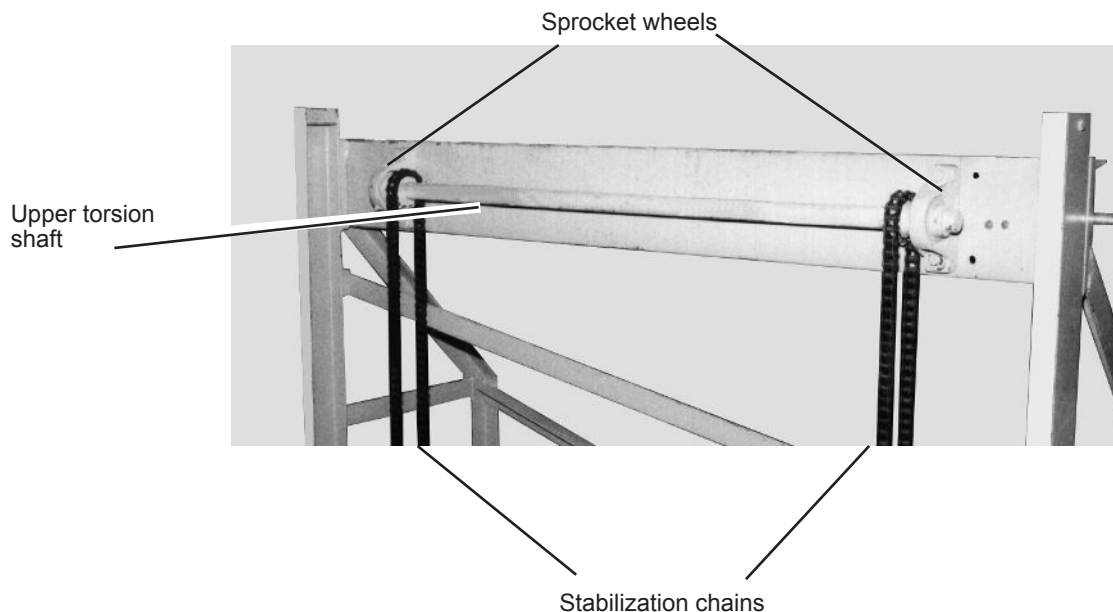
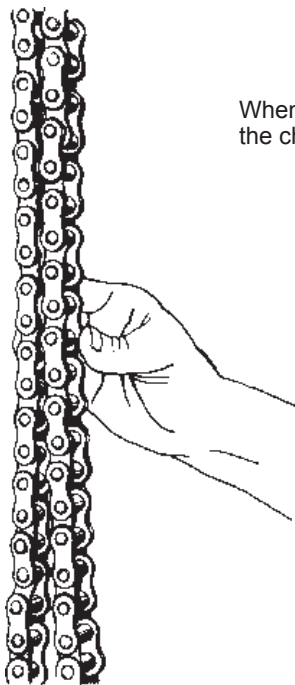
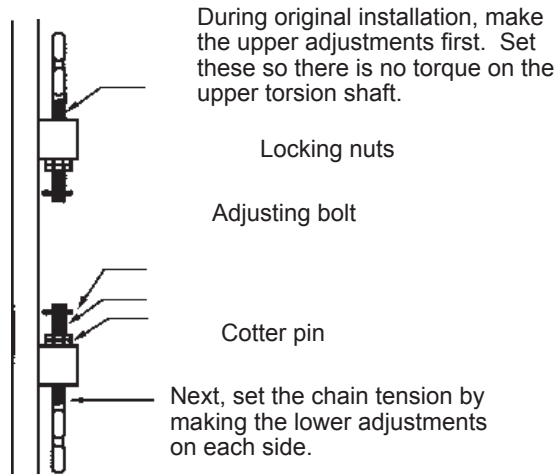

Fig. 2-13 – Stabilization Chain Mechanism

Fig. 2-14 – Initial Adjustment - Stabilization Chains



7. Press the Up pushbutton, or the button which will send the lift to the highest level. If the platform does not rise, turn in the pressure adjustment screw until the platform begins to move.
8. As the platform is rising, note the hydraulic pressure in the system. Check the pressure gauge on the hydraulic power unit.
9. When the end of the cylinder reaches the ram stop, the power unit will stop. Note the system pressure at this point. If the pressure switch is set correctly, this pressure should be 15% above the pressure when the lift is rising. If it is not, adjust the setting on the pressure switch. Turn the adjustment screw in (to increase the pressure) or out (to decrease the pressure).
10. Repeat steps 7 through 9 and check the pressures again. Continue to adjust and test until the pressure switch operates at 15% above the pressure when the lift is rising.
11. When the final pressure is correct, replace the cap over the range adjustment screw.

Testing

1. Clear the area around the VRC unit. Remove any loose wires, lumber, or other materials which might get in the way of the lift platform as it raises or lowers.
2. Warn others to stay away from the unit. Operate the lift platform through its full range of travel. The platform should rise smoothly with a quiet humming sound, and lower smoothly and quietly by gravity control knob again. Check the clearances around the lift platform.

Table 2-3 - Flow Control Locations

Type	Motor	Pump	Flow control valve location	See Fig.
Type 1 'standard'	3.2 hp	2.8 gpm	On ram	Fig. 1-25
Type 2	3.2 hp	3.9 gpm	On ram	Fig. 1-26

Vertical Reciprocating Conveyor

Completing the Installation

1. The down speed of the unit is adjustable. If the lift platform is lowering too quickly or too slowly, you can change the “down speed” by adjusting the flow control. Choose a down speed setting which suits your needs.

⚠WARNING

Do not change the setting on the flow control valve unless the lift platform has been completely lowered. Do not try to adjust the flow control while pressing the “down” button, or while the lift platform is moving. If you try this, the lift platform may drop suddenly, and you may be hurt.

2. To find the flow control, refer to the correct illustration for your power unit. See Table 2-3.
3. If you want the lift platform to lower more slowly, turn the knob on the flow control valve clockwise up to 1/4 turn at a time. Do this only after you have lowered the lift platform – never while the platform is moving. If you want the lift platform to lower more quickly, turn the control counterclockwise up to 1/4 turn. Do not move the control more than 1/4 turn at a time. This will avoid large, sudden changes in the down speed.

4. Operate the unit, and check the speed as the lift platform moves down. You may have to adjust the control knob again. Lower the platform completely before you change the setting on the flow control valve.
5. Test the unit with the rated load. If the lift platform does not rise, and you hear a loud squealing noise, the pressure relief valve is operating. See the section on “Adjusting the Relief Valve.”

⚠WARNING

Do not continue to use the unit if the relief valve opens – the pump will overheat very quickly, and may be permanently damaged. To adjust the relief valve, follow the procedure described in “Adjusting the Relief Valve” located in the Maintenance Procedures section of this manual.

6. As a final step, clean up all spilled hydraulic fluid. Spilled hydraulic oil is slippery, and may present a fire hazard. If you clean up any spilled fluid, you will be able to tell right away if the unit begins to leak.

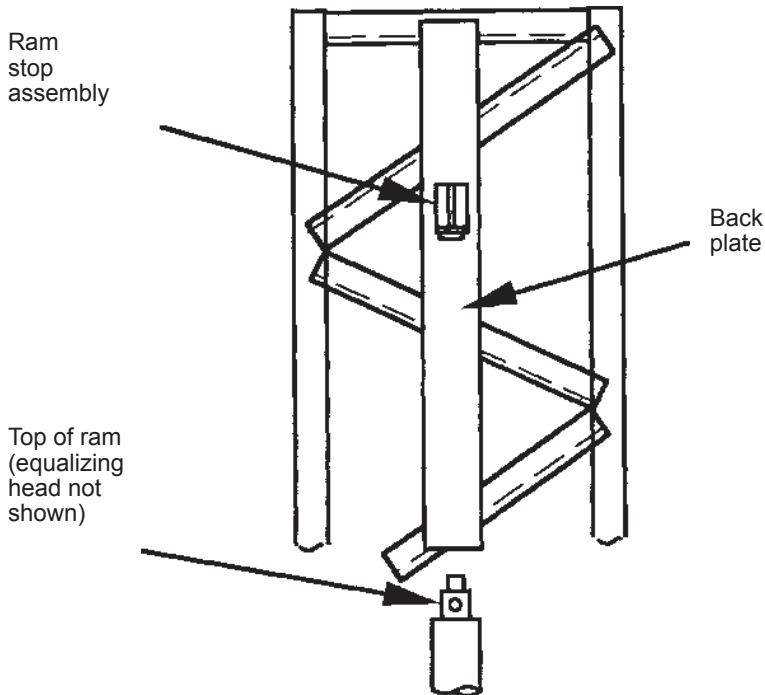

Fig. 2-15 – Installing the Ram Stop Assembly

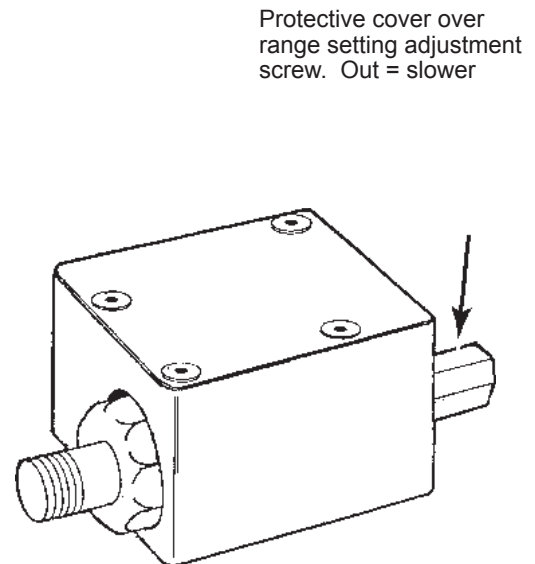

Fig. 2-16 – Optional Pressure Switch

WARRANTY

Southworth Products Corp warrants this product to be free from defects in material or workmanship for a period of **one (1) year** from date of shipment, providing claim is made in writing within said year. This warranty shall not cover failure or defective operation caused by misuse, misapplication, negligence or accident, exceeding recommended capacities, or altering or repairing, unless alteration is authorized by Southworth Products Corp. Except as set forth herein, there are no other warranties, express or implied, including the warranties of merchantability and fitness for a particular purpose, all of which are hereby excluded.

Southworth Products Corp makes no warranty or representation with respect to the compliance of any product with state or local safety or product standard codes, and any failure to comply with such codes shall not be considered a defect of material or workmanship under this warranty. Southworth Products Corp shall not be liable for any direct or consequential damages arising out of such noncompliance.

Southworth Products Corp's obligation under this warranty is limited to the replacement or repair of defective components at its factory or another location at Southworth Products Corp's discretion. The Southworth Warranty is for product sold with in North America. For products shipped outside of North America the warranty will be for replacement of defective parts only. Labor is not included. This is buyer's sole remedy. Except as stated herein, Southworth Products Corp will not be liable for any loss, injury, or damage to persons or property, nor for direct, indirect, or consequential damage of any kind resulting from failure or defective operation of said material or equipment. This warranty may be altered only in writing by Southworth Products Corp, Portland, Maine.

Southworth Products Corp is widely acknowledged as the leading maker of hydraulic lifts and materials-handling equipment. Southworth machines are rugged and reliable, and are designed to provide years of trouble-free service. The designs are based on extensive engineering experience. These are good reasons for specifying Southworth machines in your plant.

SOUTHWORTH

P.O. Box 1380, Portland, ME 04104-1380
Telephone (800) 743-1000 • (207) 878-0700 • Fax (207) 797-4734
www.SouthworthProducts.com
service@SouthworthProducts.com