

SOUTHWORTH®

Innovations in Pallet Handling

Autofeeder



Autofeeder

Warehouses, distribution centers and other material handling operations are facing ever-increasing challenges. Labor shortages, stricter safety regulations, and higher costs mean automation is no longer a “nice to have”—it’s becoming more of an essential for success.

The Southworth Autofeeder automates tasks that previously required skilled operators and manual labor. In an integrated system, the Autofeeder is positioned in front of a conveyor line. Pallets are placed on the Autofeeder, which lifts the pallets and transfers them onto the conveyor.

With the Southworth Autofeeder, you can save time, reduce the potential for workplace accidents, and maximize uptime—helping your operations stay efficient, safe, and cost-effective.

Advantages

- ✓ **Flexibility:** The Autofeeder adapts to a broad range of pallet sizes, types, and designs, making it a go-to solution for high-cycle operations.
- ✓ **Versatile Loading/Unloading:** It is engineered for loading and unloading with a standard pallet jack, eliminating the need for a forklift.
- ✓ **Optimized Space Usage:** Its compact design frees up space, allowing for more stations within the same footprint.
- ✓ **Seamless System Integration:** The Autofeeder integrates easily into existing workflows, offering compliance with safety standards while being customizable with various accessories.

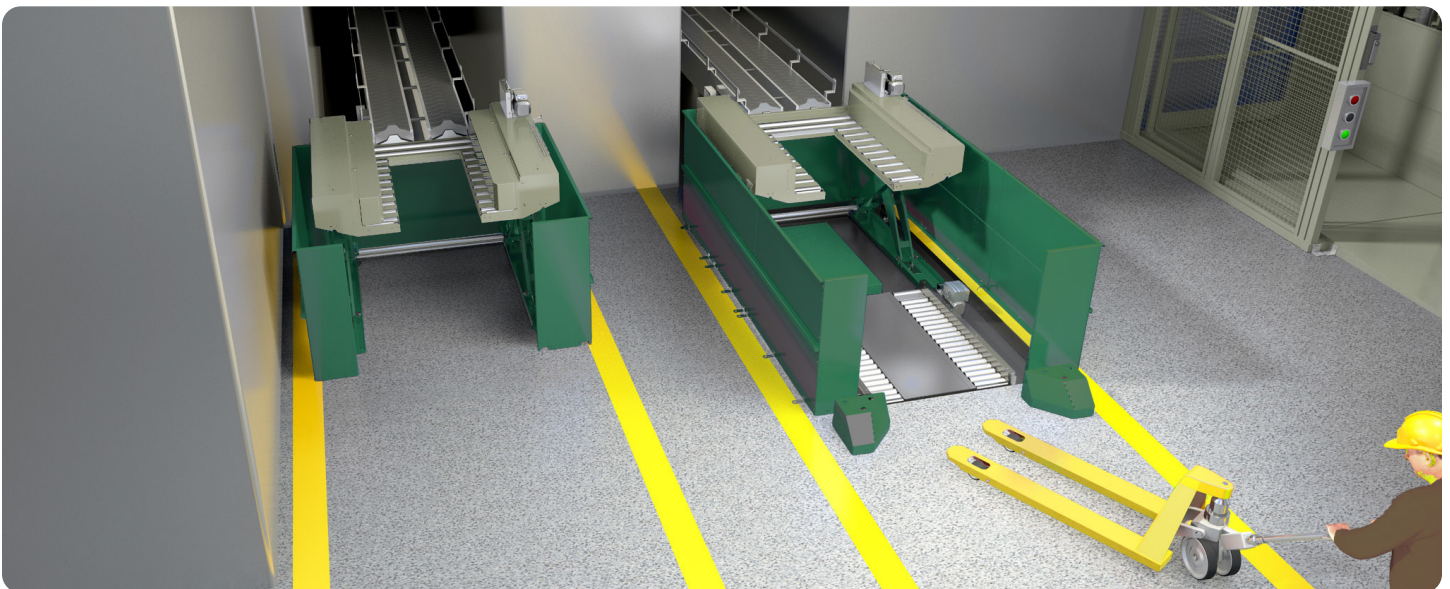
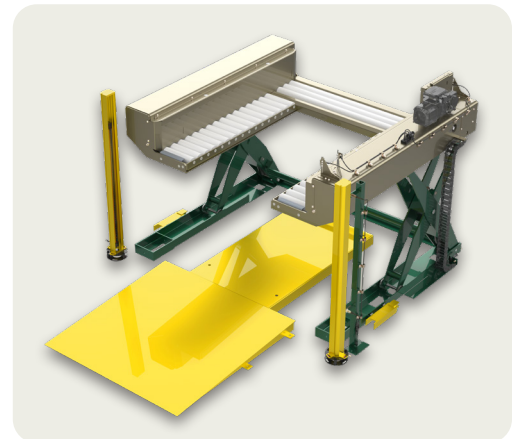

Above image shows optional design features to our standard model.

Who Benefits

The Southworth Autofeeder isn't just versatile—it's designed to meet the unique needs of key industry players.

OEMs and Integrators: Use the Autofeeder to expand your product lines and offer differentiated, world-class automation solutions.

Dealers/Selling Partners: With its simple and highly-effective configuration options, the Autofeeder makes it easier to sell customized solutions tailored to your customer needs.

End Users: Simplify your processes by eliminating the need for forklift operators. The Autofeeder is safe, cost-effective, and easy to use.

Specifications

| | | |
|---|-----------------------|-----------------------------------|
| Maximum Capacity | 3,000 lb | 1,360 kg |
| Vertical Travel | 35 in | 890 mm |
| Rise Time | 14 sec | 14 sec |
| Lowered Height (Top of Roller) | 3.375 in | 85 mm |
| Raised Height (Top of Roller) | 38.375 in | 975 mm |
| Pallet Size Options (L x W) | 48 x 40 or 48 x 48 in | 1,200 x 1,016 or 1,200 x 1,200 mm |
| Conveying Speed | 38 ft/min | 11.5 m/min |
| Pallet Infeed Opening (Maximum Inside Dimensions) | 51 in | 1,295 mm |
| Inside Dimensions Between Conveyor Frames (L x W) | 50 x 30.125 in | 1,270 x 765 mm |
| Roller Diameter | 2.5 in | 63.5 mm |
| Roller Spacing (on Center) | 3 in | 76 mm |
| Overall Width | 75 in | 1,905 mm |
| Overall Length | 65.5 in | 1,664 mm |
| Conveyor Motor (Inverter duty-rated motor is optional.) | .75 hp | .75 hp |
| Lift Motor | 3 hp | 3 hp |
| Unit Weight | 2,350 lb | 1,065 kg |

Tailored to your Application

Features one streamlined platform that you can build on to create the best solution for your application:

1. Choose between floor or pit installation and specify the pallet type and size.
2. Add safety features and select the motor type and accessories to fit your specific workflow.
3. Customize your setup with additional sensors, light barriers, and more.

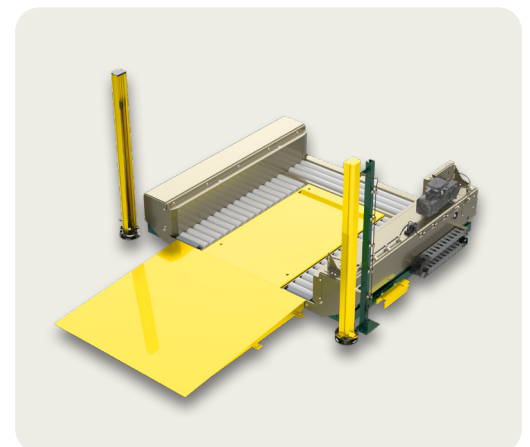

SOUTHWORTH®

To learn more about this new evolution in pallet handling, contact your Southworth representative.

Southworth Products
P.O. Box 1380
Portland, ME
04104-1380

☎ Tel: 207-878-0700

☎ Toll-Free: 800-743-1000

📧 southworthproducts.com

